

# B&B Atoll

SOFAS

2018

Antonio Citterio



## Description

---

Named after the coral formation, the modular sofa system B&B Atoll is a refined expression of a balanced aesthetic form and a decisive contemporary style that is also extremely elegant. The system is built on three basic platforms that are complemented by armrest and backrest elements to form various types of seats: sofas, dormeuses, corner-end modules, single or modular elements with chaise longue and ottomans. The frames have light, slender lines and are applied on high die-cast supports with metal profile emphasising the line between the structure and upholstery. The pieces are given even more character by a supporting element to be placed wherever desired, a bolster in two sizes attached by leather straps to a die-cast structure. This accessory can be inserted between the seat cushion and the base structure to provide an additional support or become an armrest or backrest at will. B&B Atoll is a dynamic project with a constantly fresh ability to adapt to different compositions and create different seating types, from informal relax versions to most formal, also made possible by the use of complementary back cushions.

# Technical information

---

**Internal frame**

tubular steel and steel profiles

**Internal frame upholstery**

Bayfit® flexible cold shaped polyurethane foam, polyester fibre cover

**Seat cushion**

shaped polyurethane of different density, sterilized down, polyester fibre cover

**Back cushion**

shaped polyurethane, sterilized down

**Lumbar cushion (AT45\_40)**

down feather, box style typology

**Roller**

shaped polyurethane, polyester fibre cover

**Roller support**

die-cast aluminium

**Roller webbing**

fabric or leather

**Support frame**

die-cast aluminium

**Ferrules**

plastic material

**Cover**

fabric or leather

# Technical drawings

**ATR247S\_3**

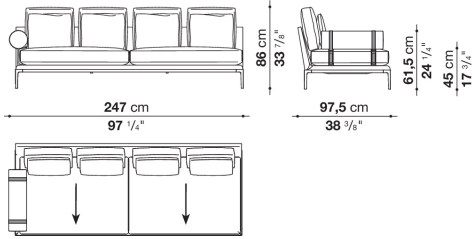

**ATR247S\_2**

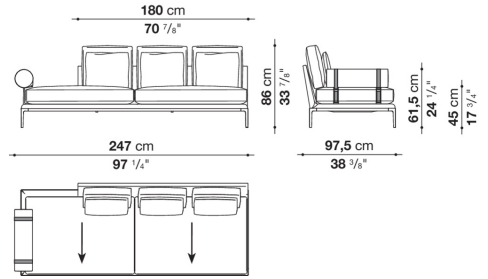

**ATR247S\_1**

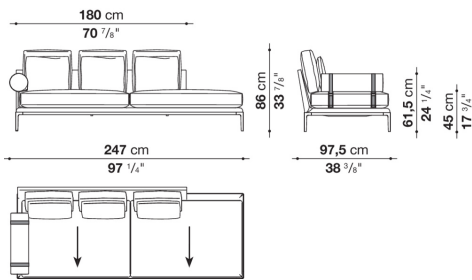

**ATR247D\_3**

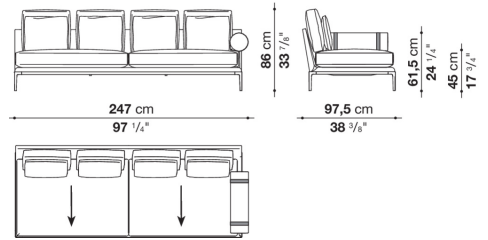

**ATR247D\_2**

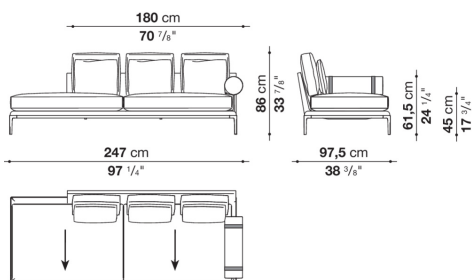

**ATR247D\_1**

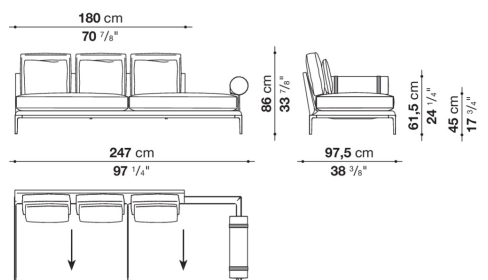

**ATR197S\_3**

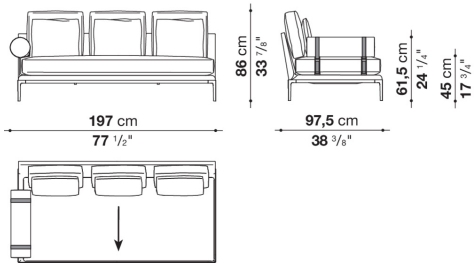

**ATR197S\_2**

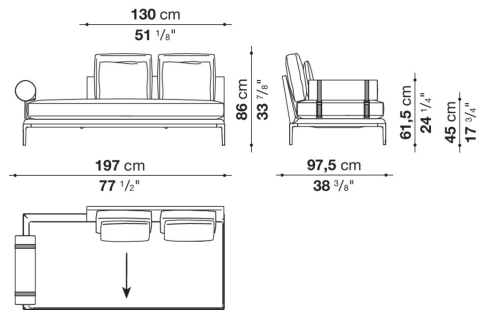

**ATR197S\_1**

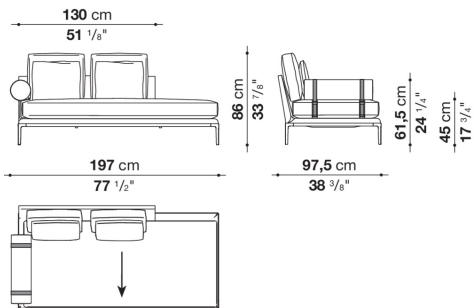

**ATR197D\_3**

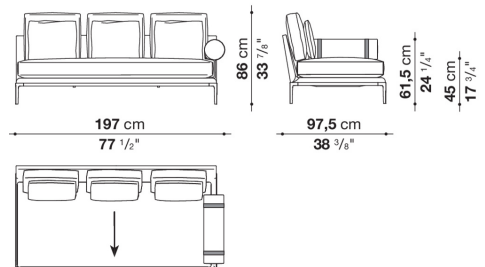

**ATR197D\_2**

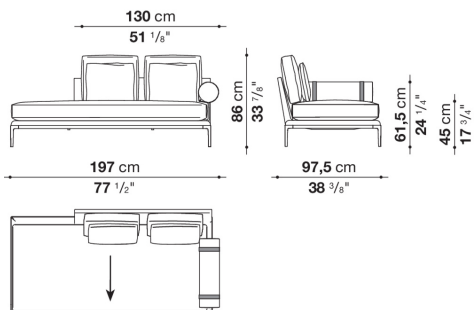

**ATR197D\_1**

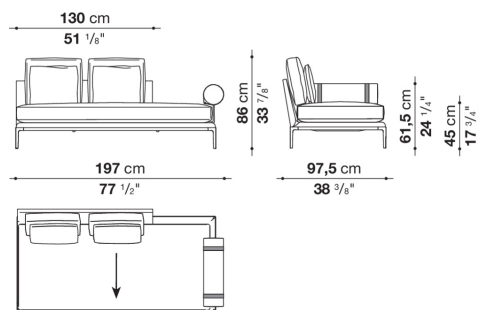

**ATR137LS**

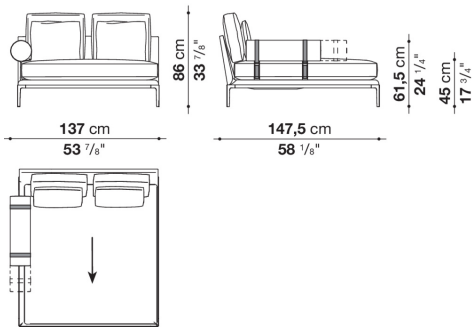

**ATR137LD**

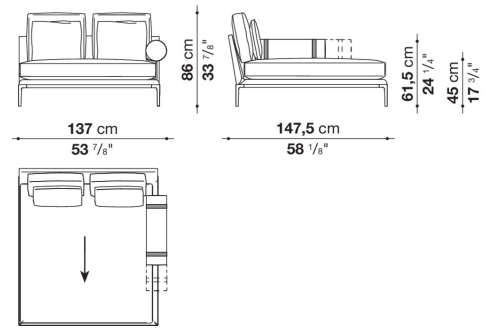

**AT248TAS\_3**

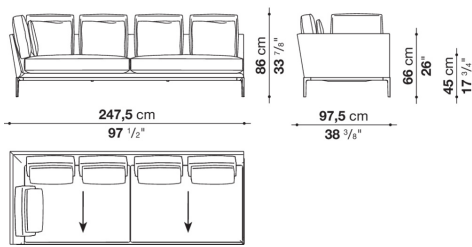

**AT248TAS\_2**

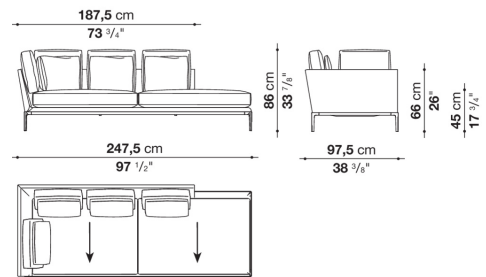

**AT248TAS\_1**

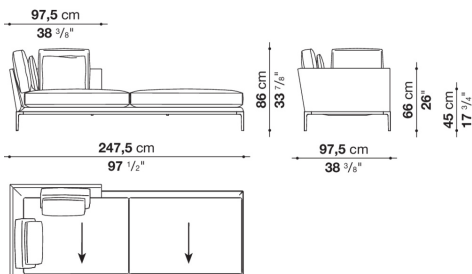

**AT248TAD\_3**

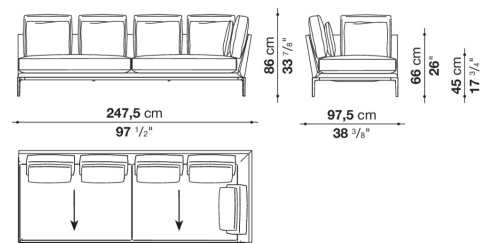

AT248TAD\_2

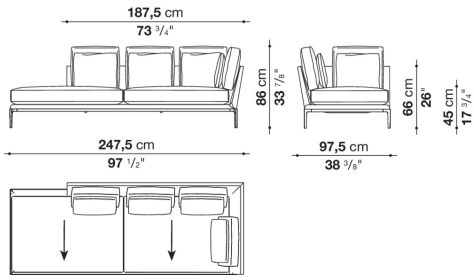

AT248S\_3

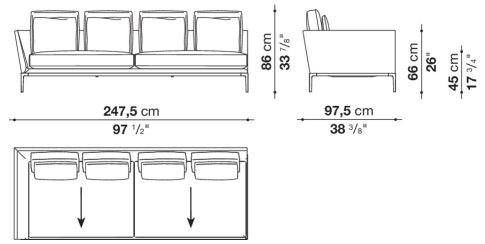

AT248TAD\_1

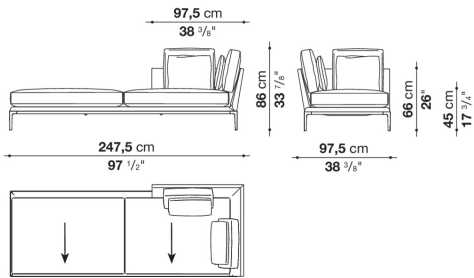

AT248S\_2

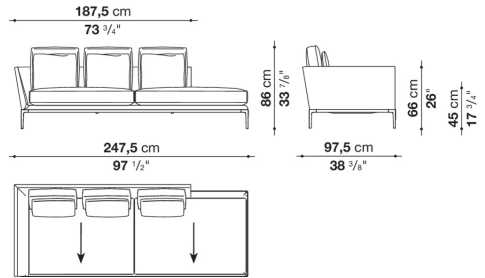

AT248S\_1

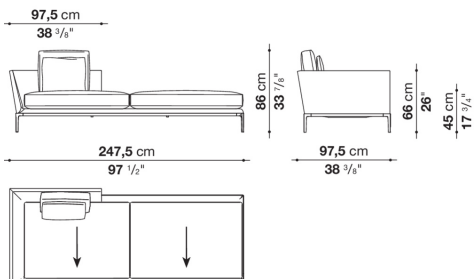

AT248LS\_2

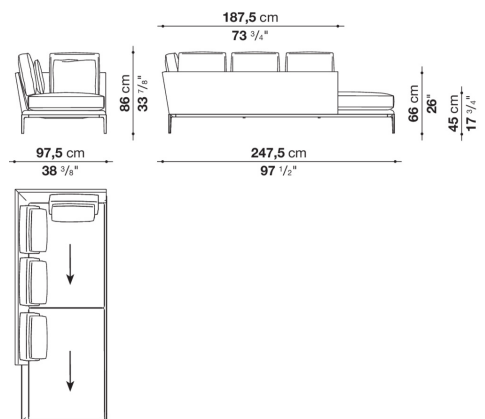

AT248LS\_1

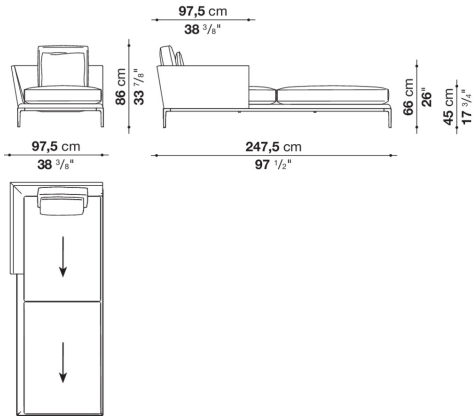

AT248LD\_2

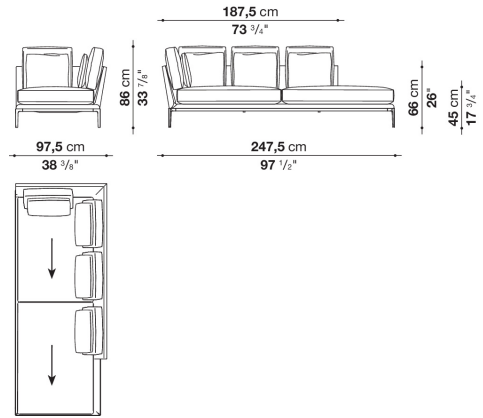

AT248LD\_1

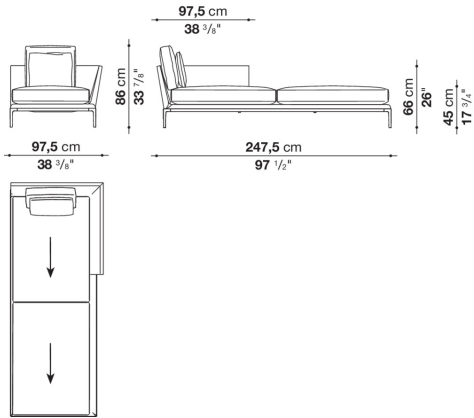

AT248D\_3

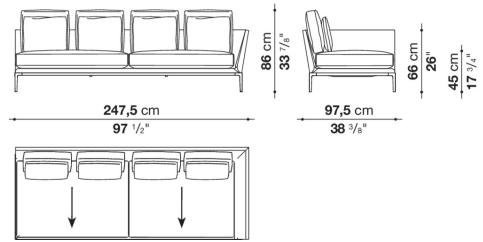

AT248D\_2

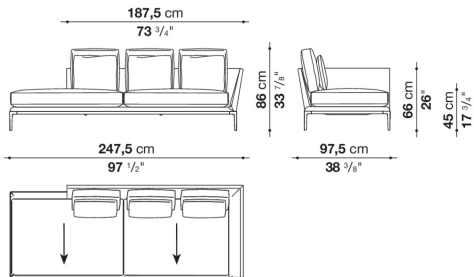

AT248D\_1

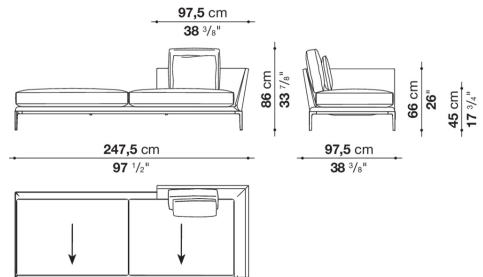

AT240PS

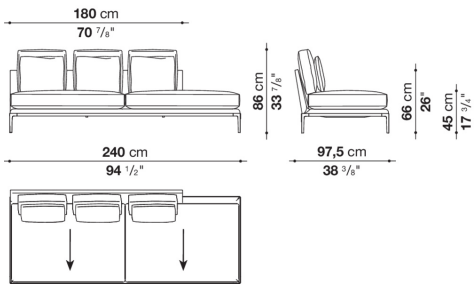

AT240PD

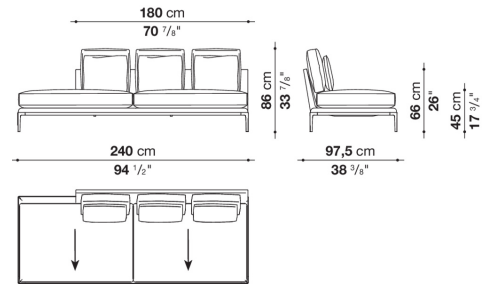

AT240C

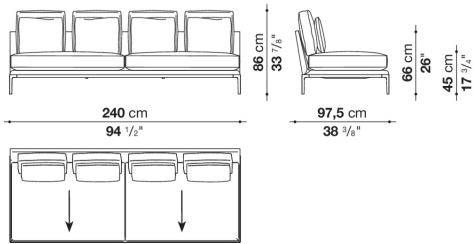

AT198TAS\_2

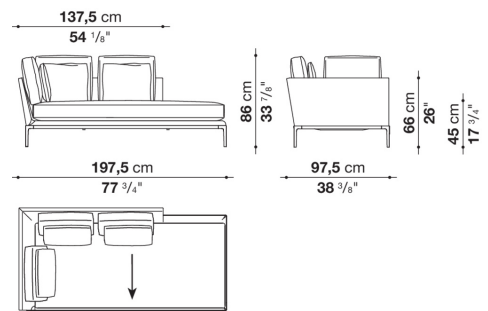

AT198TAS\_3

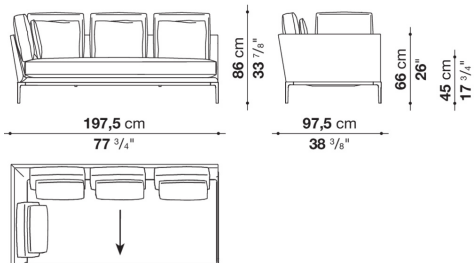

AT198TAS\_1

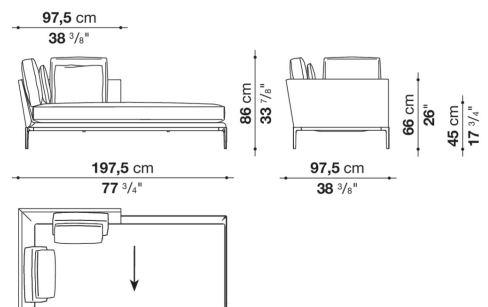



AT198TAD\_2

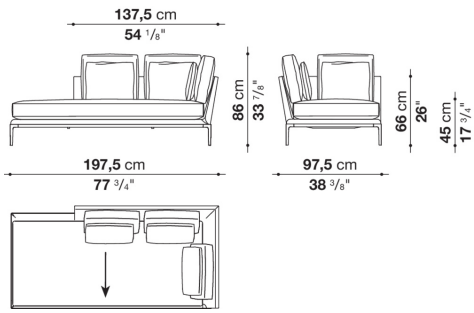

AT198TAD\_3

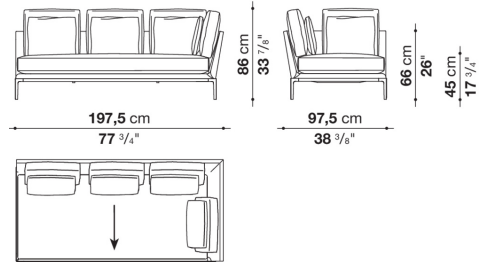

AT198TAD\_1

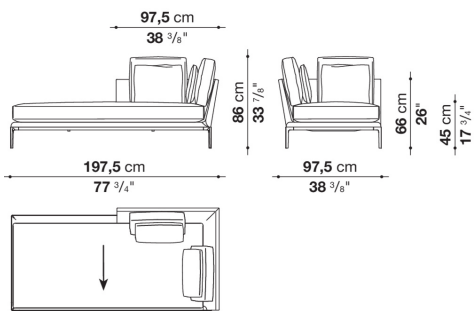

AT198S\_3

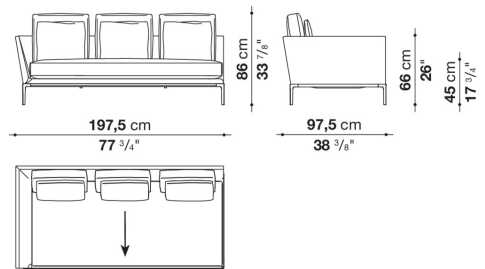

AT198S\_2

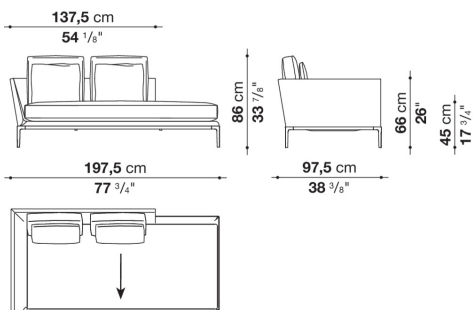

AT198S\_1

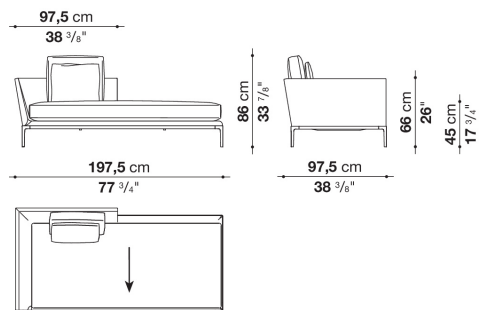

AT198LS\_2

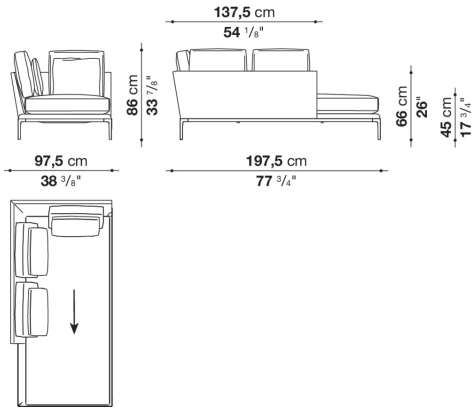

AT198LS\_1

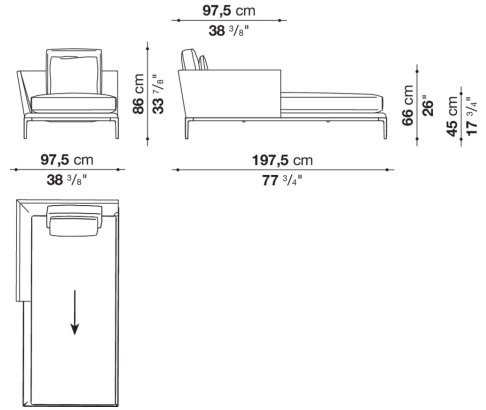

AT198LD\_2

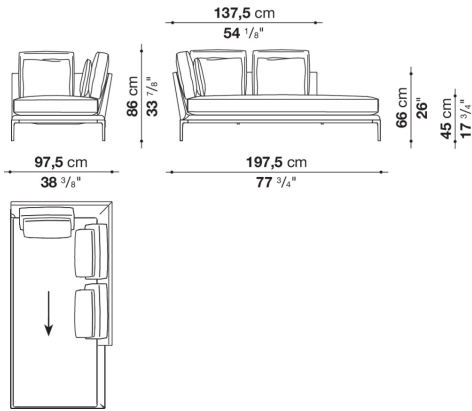

AT198LD\_1

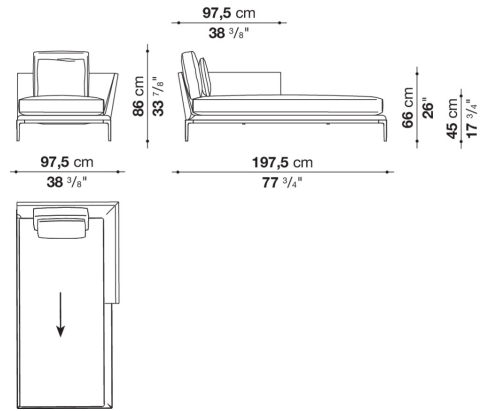

AT198D\_3

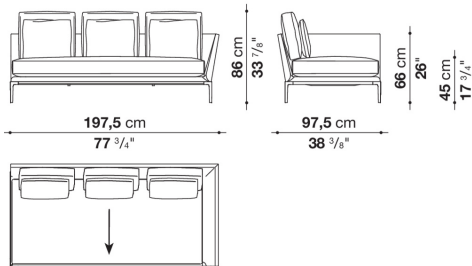

AT198D\_2

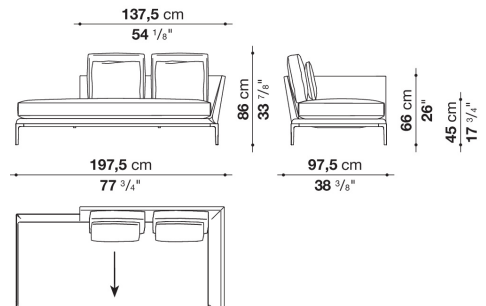

AT198D\_1

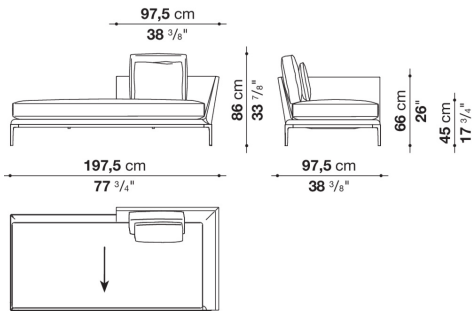

AT190C

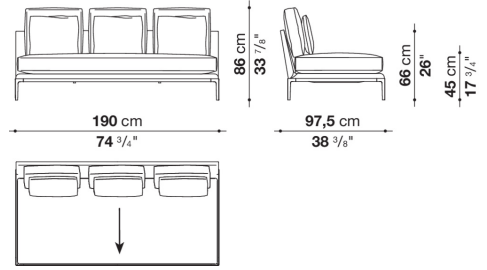

AT190PS

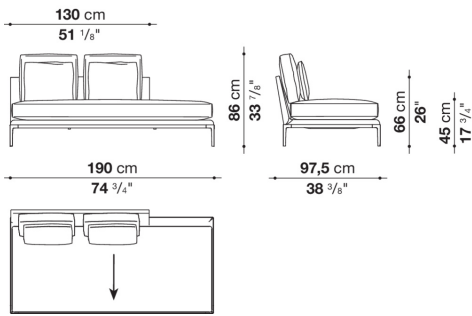

AT190PD

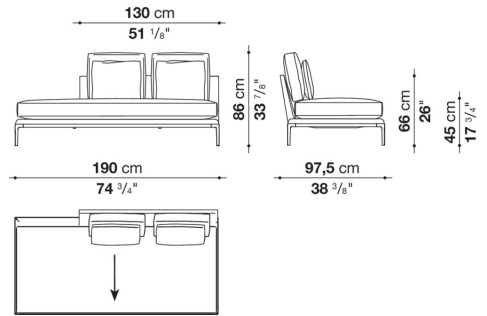

AT138LS

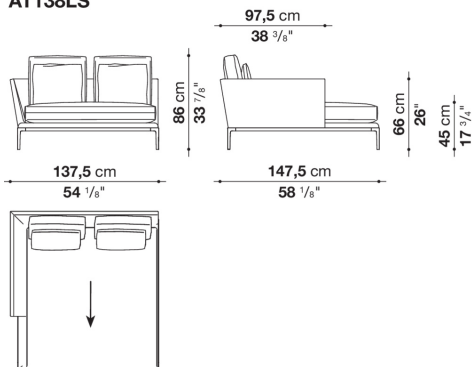

AT138LD

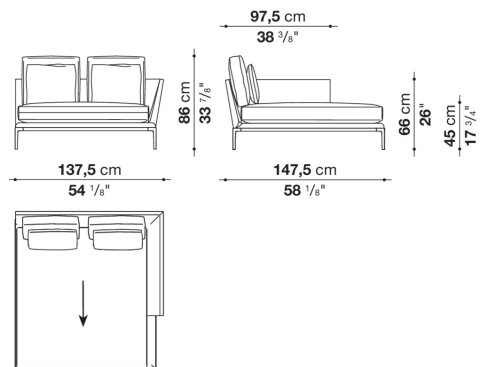

**AT130L**

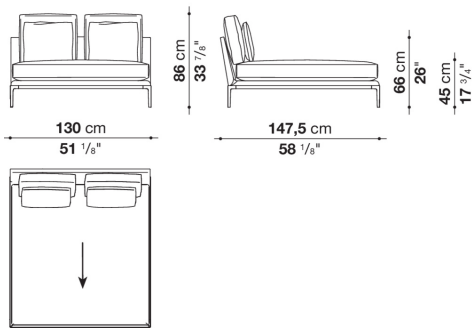

**ATR240P**

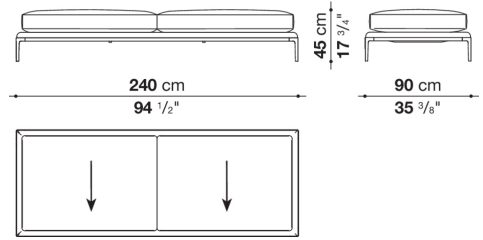

**ATR190P**

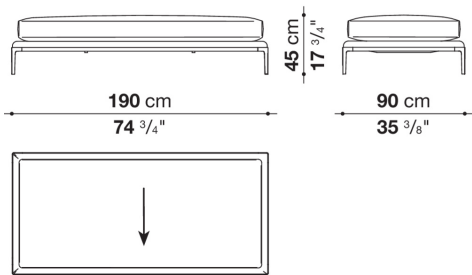

**ATR130PS**

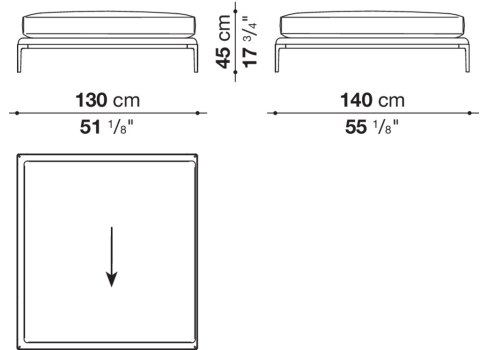

**ATR130PD**

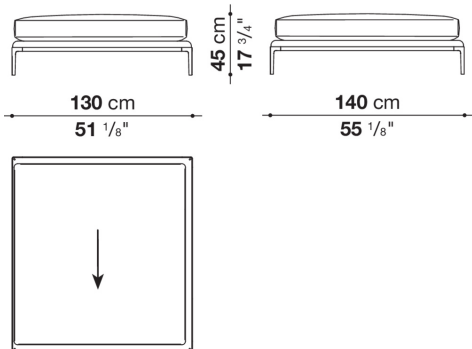

**ATR130P**

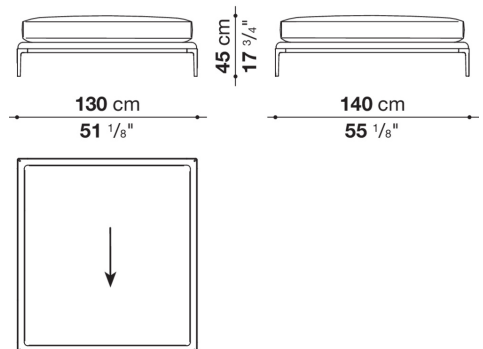

### AT89PQF

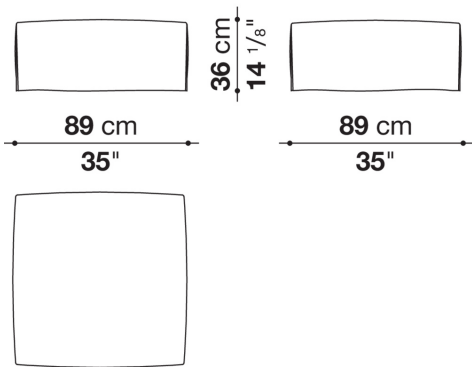

### AT154DPF

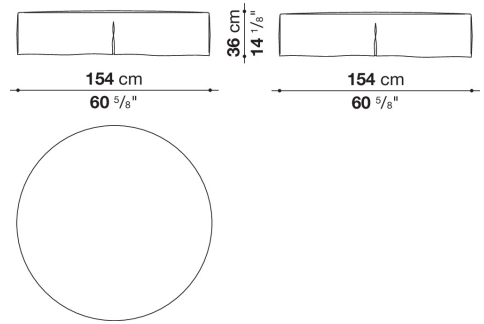

### AT153PQF

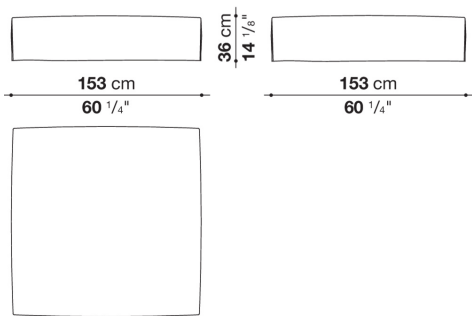

### AT153PF\_2

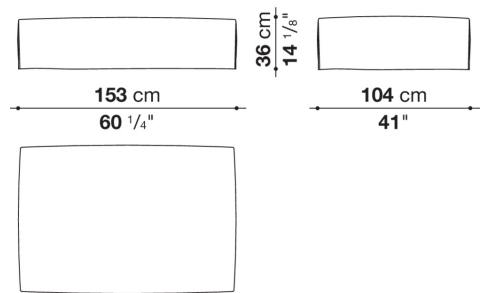

### AT153PF\_1

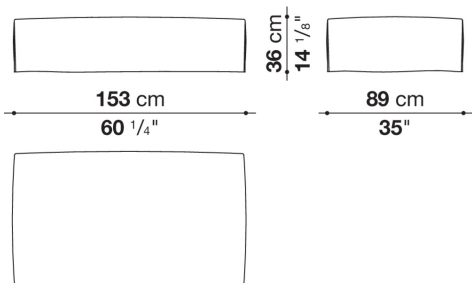

### AT110DPF

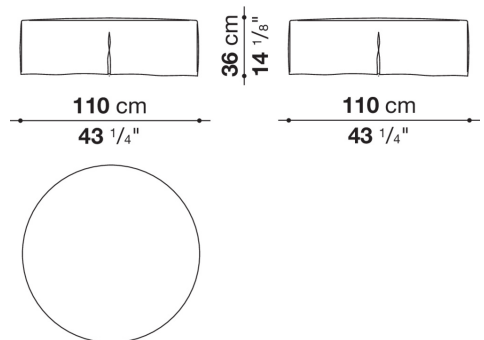

### AT104PQF

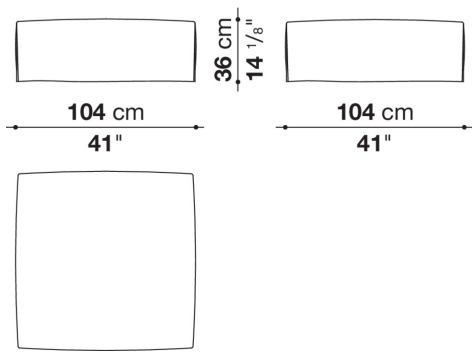

### ATR254

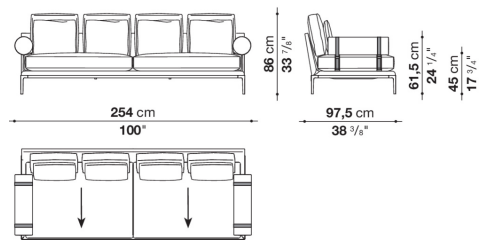

### ATR204

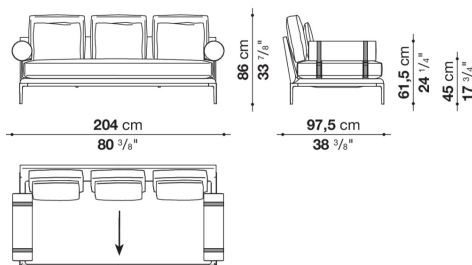

### AT255AS

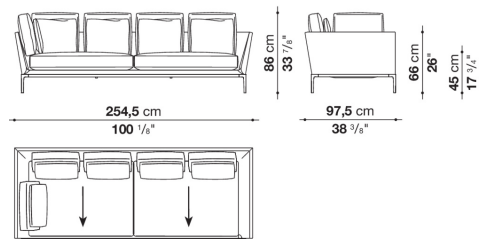

### AT255AD

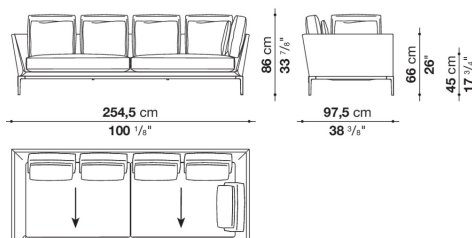

### AT255

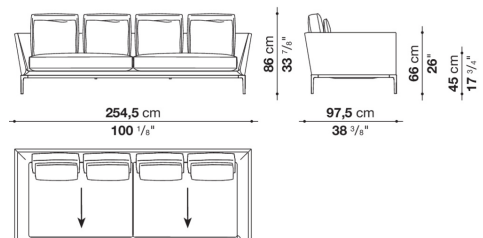

**AT205AS**

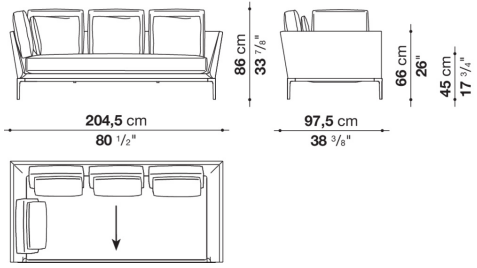

**AT205AD**

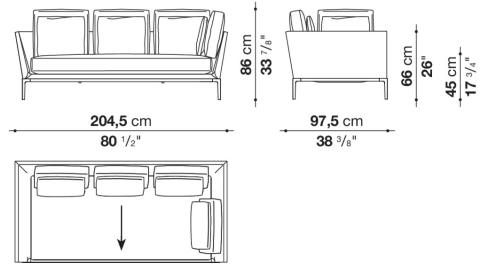

**AT205**

