

Heathfield&Co

Product Specification Sheet

TABLE LAMP | ILANA



PRODUCT INFORMATION

Base Code: TL-ILAN-SBRS-T00

Material: Ceramic

Finish shown: Moss

Metalwork: Satin Brass

Lampshade: 14" Empire / SH-14-EMPI

Flex: UK & EU 1.5 metres of Black braided flex /

US Black braided flex

TECHNICAL INFORMATION

Weight: 2.7kg / 6lbs

Plug: Black 13amp UK plug /

Black Schuko EU plug / Black US polarised plug

Switching: Black inline switch

Lamping: 1x E27 lampholder / 1x E26 US lampholder

60W max. LED lamps recommended.

Lamps not included

BASE HEIGHT: 360 mm / 14¹/₄"

TOTAL HEIGHT: 580 mm / 22³/₄"

BASE WIDTH: 200 mm / 8"

SHADE WIDTH: 350 mm / 14"

UKCA / CE / UL COMPLIANT

WARRANTY

10 years*

FINISHING NOTE

The ceramic glazes that we have used on this lamp will create differences from piece to piece - variations in colour, formation and detailing. As such, it is part of the charm that no two products are exactly the same.

CLEANING INSTRUCTIONS

The finishes on this luminaire only require regular cleaning with a soft dry duster. Abrasive or chemical cleaners may harm the finish and should not be used. Shade to be dusted with a clean dry cloth.

*Please refer to our Terms & Conditions for further information.

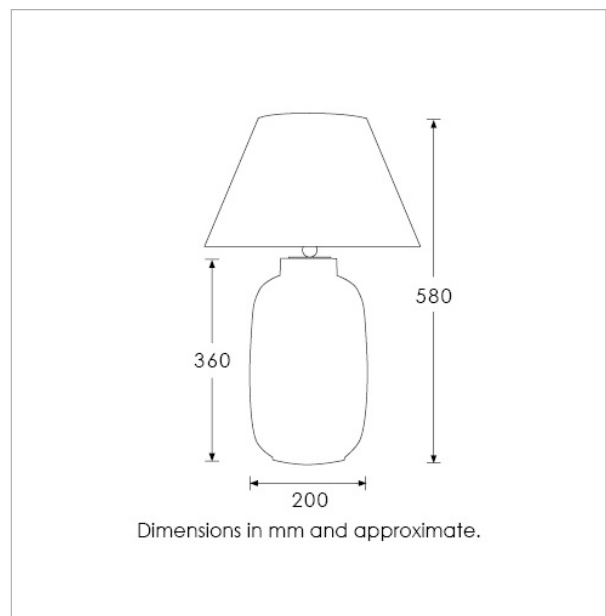

Dimensions in mm and approximate.

H&
CO

LIGHT BEYOND DESIGN