

## ESSENZE | WOODS cat. 1

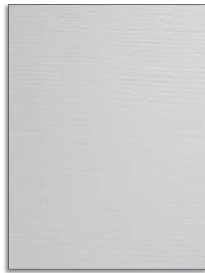

rovere nodi  
oak knots

## ESSENZA laccata | Lacquered WOOD



rovere lacc. poro aperto  
(disponibile in tutta la gamma colori)  
matt lacquered open pore oak  
(available in all the colour range)

## MATERICO | TEXTURED FINISH



effetto pelle colore zenzero  
leather effect zenzero colour  
(disponibile solo per schienali attrezzabili Slim ed el. 3 cassettoni Speed)  
(available only for Slim back panels and Speed el. 3 drawers)



rovere termotrattato  
heat-treated oak  
(disponibile solo per schienali attrezzabili Slim e sistema Speed)  
(available only for Slim back panels and Speed system)

## ESSENZE | WOODS cat. 2

laccati opachi per interni abbinati alle essenze | matt lacquers for interiors matched with woods

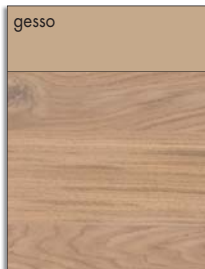

rovere gesso  
oak gesso



rovere visone  
oak visone



rovere cenere  
oak cenere

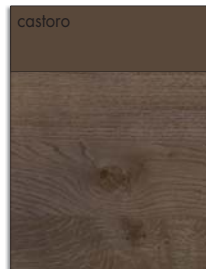

rovere castoro  
oak castoro



rovere termotrattato  
heat-treated oak

## SUPERFICI UP | UP SURFACE

### laccati effetto resina | resin effect lacquered finish



light grey



dark grey

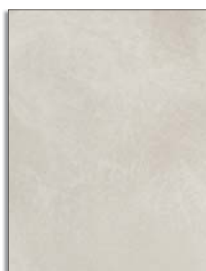

tortora



terracotta

### laccati metallici | metal effect lacquer



titanio



nichel



piombo

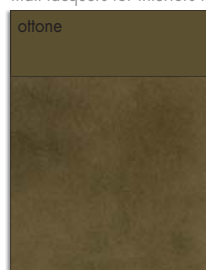

ossido ottone

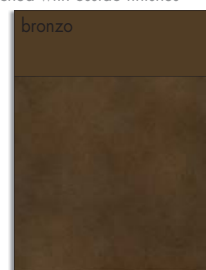

ossido bronzo

laccati opachi per interni abbinati agli ossidi  
matt lacquers for interiors matched with ossido finishes

N.B.: La riproduzione dei colori su carta può risultare alterata rispetto agli originali, pertanto queste tinte sono da considerarsi puramente indicative.

N.B.: The reproduction of the colours on paper may be different with respect to the original colours, therefore these shades should be considered representative only.

LACCATI OPACHI E LUCIDI | MATT AND GLOSSY LACQUERS

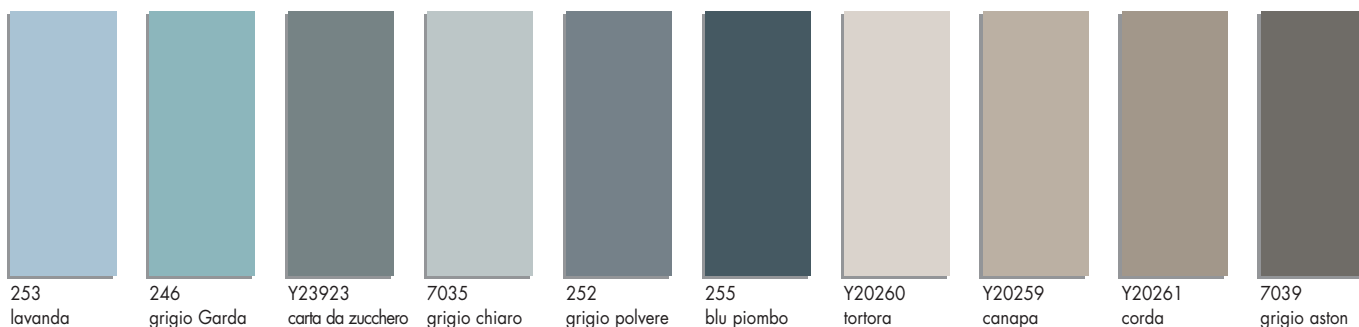
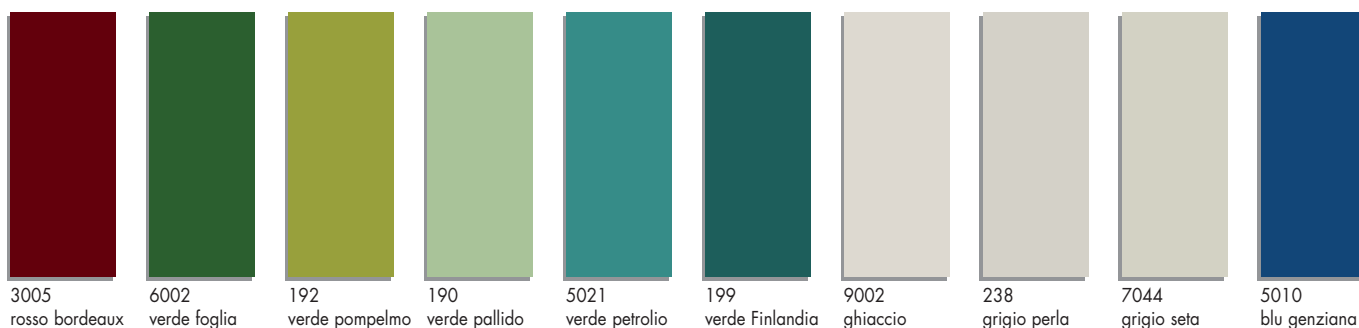
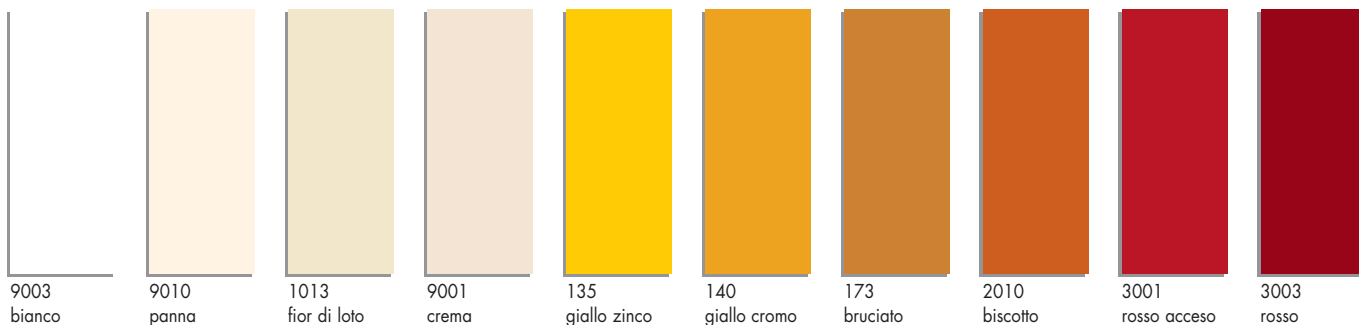

LACCATI OPACHI MICALIZZATI  
METALLIC MATT LACQUERS

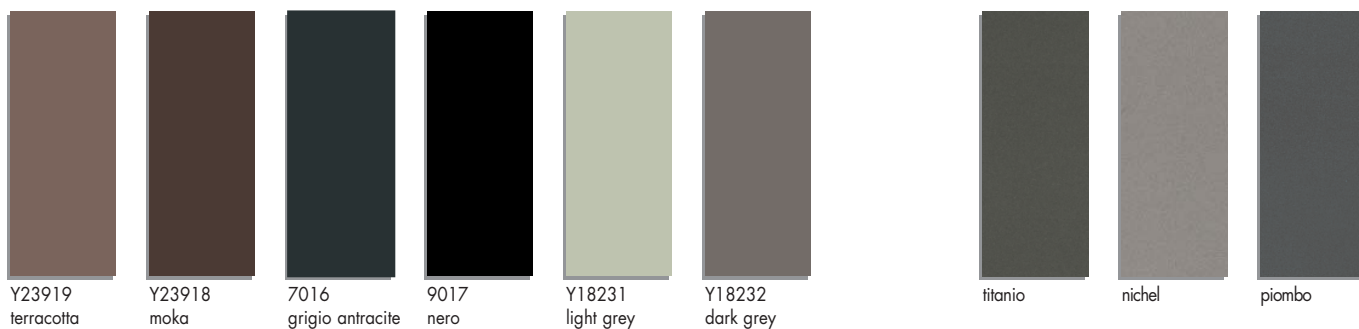

Le vernici all'acqua utilizzate permettono di ridurre le emissioni di solventi in atmosfera, sono contraddistinte dall'assenza di odori e tutelano la salute dell'operatore e dell'utilizzatore finale.  
Water-based varnishes they allow the reduction of the atmospheric emission of solvents and are characterized by the lack of scent, safeguarding the operator's and end consumer's health.

**MANIGLIE SLIM | SLIM HANDLES**



finitura brown  
brown finish



finitura bianco  
white finish



laccato opaco (disponibile in tutta la gamma colori)  
matt lacquered (available in all the colour range)

**MANIGLIE: GOLA e XL - ELEMENTI IN METALLO | HANDLES: GROOVE and XL - METAL ELEMENTS**



maniglia Gola  
Groove handle



maniglia XL  
XL handle

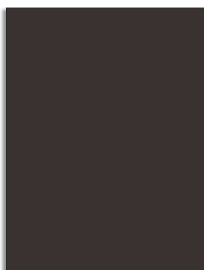

finitura brown  
brown finish



finitura bianco  
white finish



finitura ottone  
brass finish



finitura titanio  
titanium finish

**Top LAMINAM®**

**noir desir**



opaco | matt  
cat. 1

lucidato | glossy  
cat. 2

**calacatta oro**



opaco | matt  
cat. 1

lucidato | glossy  
cat. 2

**orobico grigio**



opaco | matt  
cat. 1

lucidato | glossy  
cat. 2

N.B.: La riproduzione dei colori su carta può risultare alterata rispetto agli originali, pertanto queste tinte sono da considerarsi puramente indicative.

N.B.: The reproduction of the colours on paper may be different with respect to the original colours, therefore these shades should be considered representative only.

**TELAI ANTE VETRO SLIM - BATTENTI E A RIBALTA | FRAMES FOR HINGED AND FLAP SLIM GLASS DOORS**



finitura brown  
brown finish



finitura bianco  
white finish

**TELAI ANTE VETRO UP - BATTENTI | FRAMES FOR HINGED UP GLASS DOORS**



finitura brown - vetro disponibile solo in finitura trasparente grigio  
brown finish - available only in grey transparent glass

**VETRI | GLASSES cat. 1**



sabbia chiaro  
light sand



sabbia scuro  
dark sand



corda  
rope



grigio pietra  
stone grey



grigio chiaro  
light grey



grigio medio  
medium grey



grigio polvere  
powder grey



giallo cromo  
chrome yellow



verde pompelmo  
grapefruit green



rosso rubino  
ruby red

**VETRI | GLASSES cat. 2**



nero  
black



stopsol fumé  
smoke-grey stopsol



specchio  
mirror



specchio bronzo  
bronze mirror



specchio fumo  
smoke mirror



trasparente  
transparent



trasparente grigio  
grey transparent



bianco

\* ATTENZIONE: i vetri stopsol fumé e trasparenti lasciano intravedere il telaio sottostante dell'anta vetro Slim.

\* ATTENTION: the smoke-grey stopsol and transparents glasses allow a glimpse of the underlying frame of Slim glass door.



Maniglie   Handles	P. 3
--------------------	------

### **SLIM UP**

Caratteristiche tecnico-dimensionali   Technical-dimensional characteristics	P. 7
Basi a terra o in appoggio   Free-standing or supported bases	P. 16
Basi sospese   Suspended bases	P. 32
Elementi a terra o in appoggio   Free-standing or supported elements	P. 49
Elementi sospesi   Suspended elements	P. 54
Scocche vuote basi ed elementi   Empty bodies for bases and elements	P. 59
Basi ad angolo   Corner bases	P. 71
Top per basi ed elementi   Tops for bases and elements	P. 72
Ribalte pensili   Flap-door wall units	P. 75
Scocche vuote ribalte pensili   Empty bodies for flap-door wall units	P. 78
Pensili anta battente a terra o sospesi   Free-standing or suspended hinged-door wall units	P. 81
Scocche vuote pensili anta battente   Empty bodies for hinged-door wall units	P. 93
Top per ribalte e pensili anta battente   Tops for flap-door and hinged-door wall units	P. 97
Scaffalature pensili   Wall shelving system	P. 98
Cubotti in legno   Wooden cube-shaped elements	P.100
Elementi pensili a giorno   Open wall unit elements	P.102
Piani sp. 50 e sp. 100   Benches th 50 and th. 100	P.107
Mensole sp. 30 - 50 e mensole vassoio in metallo   Shelves th. 30 - 50 and metal tray shelves	P.109
Pannelli boiserie sp. 60   Boiserie panels th. 60	P.110
Schienali attrezzabili sp. 35   Accessorized back panels th. 35	P.114
Porta TV sospeso con mensole   Suspended TV stand with shelves	P.116
Soluzioni su misura   Custom solutions	P.117
Accessori, luci e passacavi   Accessories, lights and cable duct	P.118
Modulo ed esempio d'ordine   Sample order form and order form	P.120
Composizioni fotografiche   Photo compositions	P.122

### **SPEED UP**

Caratteristiche tecnico-dimensionali   Technical-dimensional characteristics	P.126
Spalle   Structural side panels	P.133
Ripiani   Shelves	P.139
Schiene   Backs	P.144
Top per librerie   Tops for bookcases	P.143
Mediacenter e schienale per TV   Mediacenter and TV panel	P.146
Cassetti, cestoni ed ante   Drawers, deep drawers and doors	P.151
Angoli ciechi e a giorno   Blind and open corner units	P.161
Scala   Ladder	P.165
Elementi a giorno e contentitori sporgenti   Open elements and jutting storage units	P.166
Piani sporgenti, scrittoi, scrivanie e home office   Protruding tops, desk tops, writing desks and home office	P.170
Soluzioni su misura e bifacciale   Custom and double-sided solutions	P.175
Accessori, luci e passacavi   Accessories, lights and cable duct	P.177
Colonne   Columns	P.178
Modulo ed esempio d'ordine   Sample order form and order form	P.188
Composizioni fotografiche   Photo compositions	P.190
Condizioni generali di vendita   General sale conditions	P.192



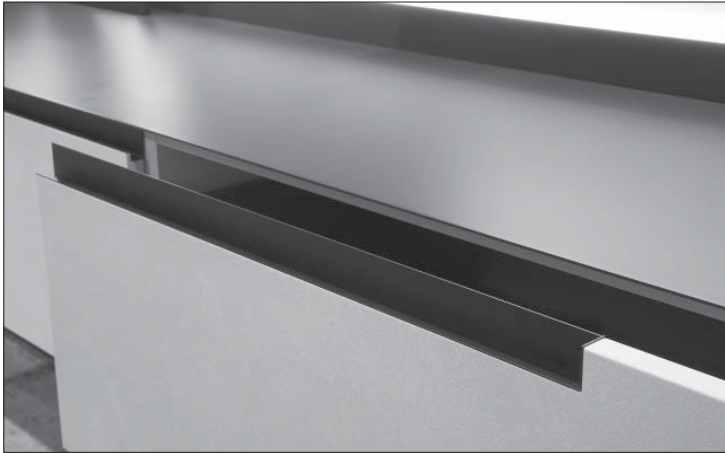

DIMENSIONI : L. 320 - 480 - 800 - 640 - 960 - 1280 - 1600 - 1920  
DIMENSIONS

FINITURA \*: brown  
FINISH bianca | white  
titanio | titanium  
ottone | brass

\* Finitura da specificare sempre nell'ordine.  
\* The finish must always be specified in the order.

N.B.: Tutti i prezzi degli elementi a listino sono calcolati con apertura "push and pull". È prevista una maggiorazione maniglia nel quale è incluso anche la differenza di prezzo per il cambio di ferramenta (nei cassetti/cestoni con maniglia vengono impiegate guide ammortizzate).

N.B.: All the prices of the elements in the price list are calculated with the "push and pull" opening. A handle surcharge is provided which also includes the price difference for the hardware change (damped guides are used in the drawers / deep drawers with handle).

ESEMPI DI APPLICAZIONE MANIGLIE SUI FRONTALI | EXAMPLES OF THE APPLICATION OF HANDLES ON THE FRONTS

Maniglie orizzontali applicate su frontali cassetti, cestoni e ribalte | Horizontal handles applied on drawer, deep drawer and flap-door fronts

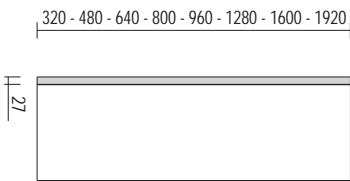

INTERA | ENTIRE

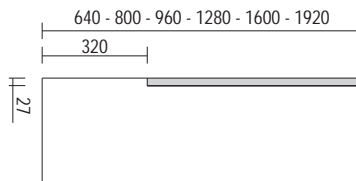

PARZIALE DX | PARTIAL RH

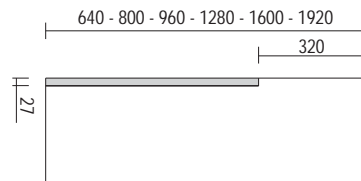

PARZIALE SX | PARTIAL LH

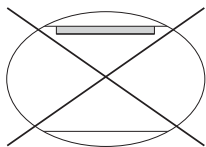

PARZIALE DX | PARTIAL RH

PARZIALE SX | PARTIAL LH

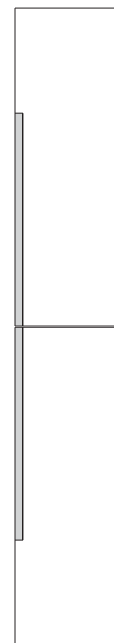

PARZIALE ALTA  
PARTIAL UP

PARZIALE BASSA  
PARTIAL DOWN

Maniglie verticali applicate su frontali ante battenti | Vertical handles applied on hinged-door fronts

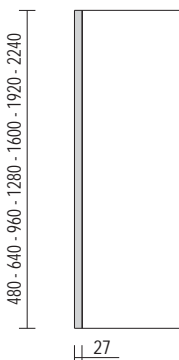

INTERA | ENTIRE

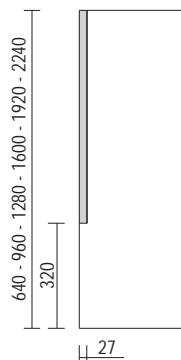

PARZIALE ALTA  
PARTIAL UP

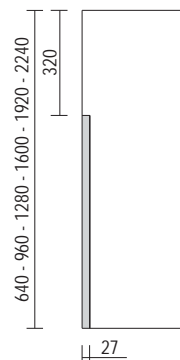

PARZIALE BASSA  
PARTIAL DOWN





DIMENSIONI : L. 480 - 640  
DIMENSIONS

FINITURA \*: brown  
FINISH bianca | white  
          titanio | titanium  
          ottone | brass

\* Finitura da specificare sempre nell'ordine.  
\* The finish must always be specified in the order.

N.B.: Tutti i prezzi degli elementi a listino sono calcolati con apertura "push and pull". È prevista una maggiorazione maniglia nel quale è incluso anche la differenza di prezzo per il cambio di ferramenta.

N.B.: All the prices of the elements in the price list are calculated with the "push and pull" opening. A handle surcharge is provided which also includes the price difference for the hardware change.

## ESEMPI DI APPLICAZIONE MANIGLIE SUI FRONTALI | EXAMPLES OF THE APPLICATION OF HANDLES ON THE FRONTS

Maniglie verticali applicate su frontali ante battenti | Vertical handles applied on hinged-door fronts

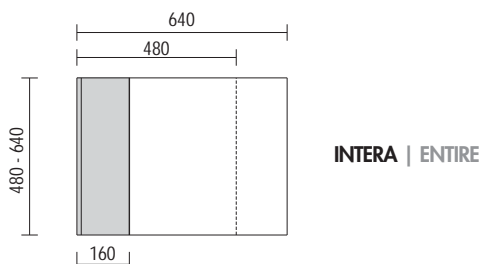

## ESEMPI DI ABBINAMENTO TRA MANIGLIA XL E GOLA | EXAMPLES OF XL AND GROOVE HANDLE COMBINATIONS

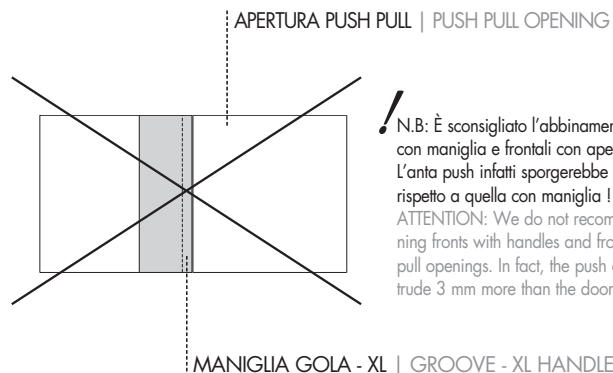
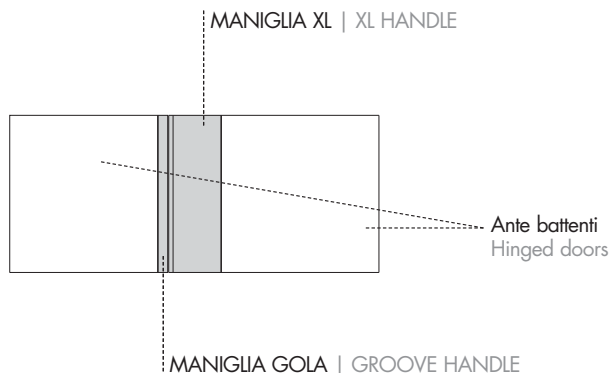

! N.B.: È sconsigliato l'abbinamento tra frontali con maniglia e frontali con apertura push pull. L'anta push infatti sporgerebbe di 3 mm in più rispetto a quella con maniglia!  
ATTENTION: We do not recommend combining fronts with handles and fronts with push-pull openings. In fact, the push door would protrude 3 mm more than the door with a handle!



DIMENSIONI : E - L. 316  
 DIMENSIONS D - L. 472  
 A - L. 632  
 B - L. 792  
 C - L. 952  
 F - L. 1112

FINITURA \*: brown  
 FINISH bianca / white



\* Finitura da specificare sempre nell'ordine; a richiesta verniciata colore a cartella con maggiorazione (vedi pag. 117).

\* The finish must always be specified in the order; on request, with a surcharge, available in the painted version, accordingly to our colour range (see page 117).

N.B.: Tutti i prezzi degli elementi a listino sono calcolati con apertura "push and pull". È prevista una maggiorazione maniglia nel quale è incluso anche la differenza di prezzo per il cambio di ferramenta (nei cassetti/cestoni con maniglia vengono impiegate guide ammortizzate).

N.B.: All the prices of the elements in the price list are calculated with the "push and pull" opening. A handle surcharge is provided which also includes the price difference for the hardware change (dampened guides are used in the drawers / deep drawers with handle).

ESEMPI DI APPLICAZIONE MANIGLIE SUI FRONTALI | EXAMPLES OF THE APPLICATION OF HANDLES ON THE FRONTS

Maniglie applicate su frontali cassetti, cestoni, ante battenti e ribalte / Handles applied on drawer, deep drawer, hinged-door and flap-door fronts

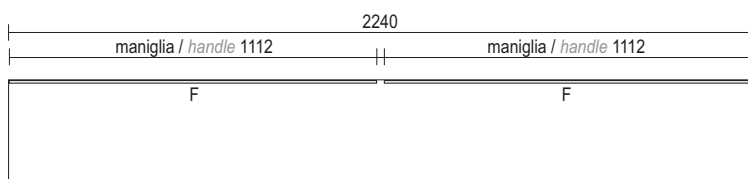
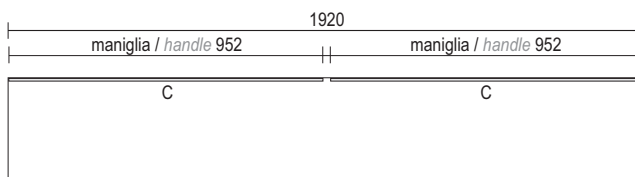
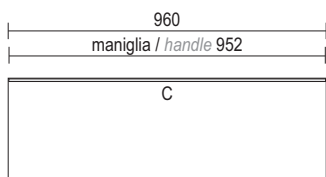
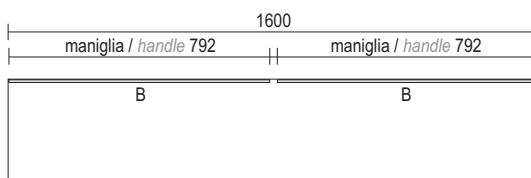
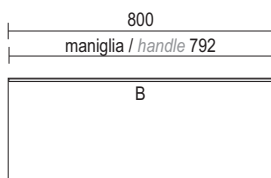
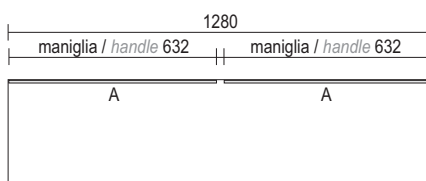
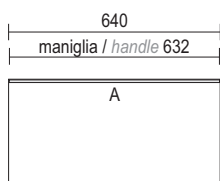

Maniglie applicate su frontali cassetti, cestoni, ante battenti / Handles applied on drawer, deep drawer and hinged-door fronts

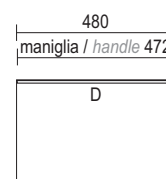
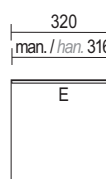

## POSIZIONAMENTO MANIGLIE SLIM | POSITIONING OF SLIM HANDLES

- L'apertura di serie è con sistema "push and pull", a richiesta sull'ordine può essere inserita la maniglia con le modalità di seguito indicate:
  - The standard opening is the 'push and pull' system, however the handle can be included on request in the order as follows:

FRONTALI CASSETTI, CESTONI O RIBALTE:  
POSIZIONAMENTO ORIZZONTALE  
DRAWER, DEEP DRAWER OR FLAP-DOOR FRONTS:  
HORIZONTAL POSITIONING

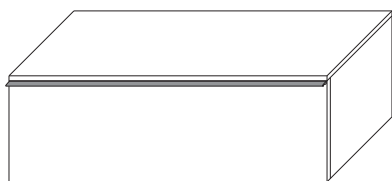

FRONTALI ANTE BATTENTI:  
POSIZIONAMENTO VERTICALE  
HINGED-DOOR FRONTS:  
VERTICAL POSITIONING

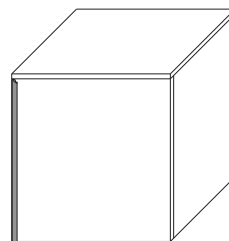

ATTENZIONE.

- Nelle ante vetro a telaio e in quelle scorrevoli non è previsto l'inserimento della maniglia.

ATTENTION.

- Handles are not provided for frame glass doors or sliding ones.

## ALLINEAMENTO SENZA MODULARITÀ | ALIGNMENT WITHOUT MODULARITY

- Gli elementi che nell'allineamento non seguono una regola di modularità saranno collegati tramite viti autofilettanti (vedi es. sotto riportato).
- The elements which do not follow a modularity rule in the alignment will be connected using self-threading screws (see the example shown below).

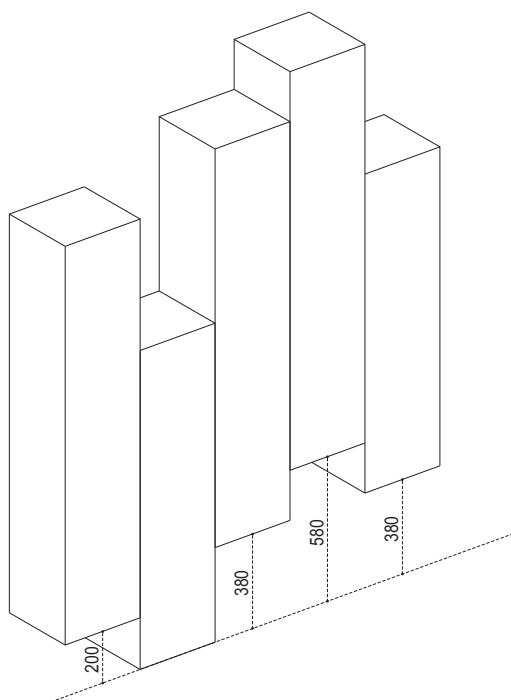

**ESEMPIO DI UTILIZZO TOP LEGNO SP.15 E LAMINAM® SP.5,5 | EXAMPLE OF THE USE OF TOPS: WOOD TH.15, LAMINAM® TH.5,5**

- Quando vengono accostati basi o elementi, anche di larghezze diverse tra loro, andrà sempre aggiunto un top intero fino alla lunghezza massima di 3840 per il top legno e di 2880 per il Laminam®.
- When bases or elements are placed one next to the other, even if they have different sizes, a whole-piece top with a maximum length of 3840 for wooden top and 2880 for Laminam® top, shall always be added.

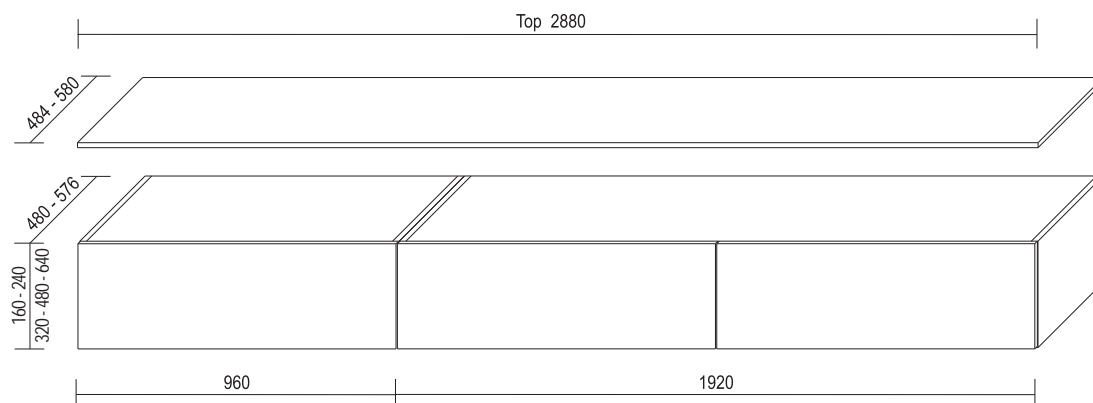

$TOP = 960 + 1920 = 2880$   
 (per le dimensioni e i prezzi vedi pag. / for the dimensions and prices, see page 72)

**ESEMPI DI COMBINAZIONI CON TOP IN METALLO | EXAMPLE OF COMBINATIONS WITH A METAL TOP**

- I top in metallo sp. 3 mm possono essere utilizzati da soli oppure in abbinamento ad alzatina (con e senza luce led) con fianchi in metallo.
- Sono disponibili in dimensione intera fino alla larghezza 2560 mm, oltre devono essere accostati per arrivare alla dimensione desiderata.
- The 3 mm-thick metal tops can be used on their own or in combination with a metal back panel (with or without an LED light) and side panels.
- They are available in a single piece up to 2560 mm. For bigger sizes, the panels are fitted one next to the other in order to achieve the desired size.

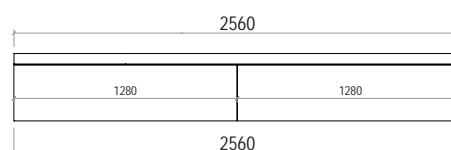
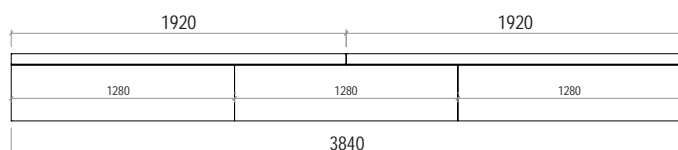
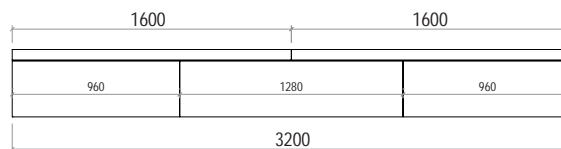
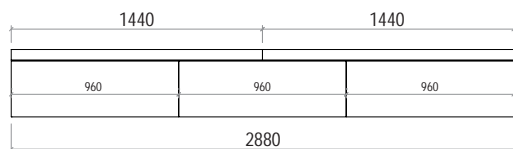

**BASI ED ELEMENTI A TERRA, IN APPOGGIO O SOSPESI | FREE-STANDING, SUPPORTED OR SUSPENDED BASES AND ELEMENTS**

- Le basi e gli elementi a terra sono forniti di piedini regolabili H.16.
- Specificare nell'ordine se posizionati a terra, in appoggio o sospesi.
- Aggiungere sempre il top.
- The free-standing bases and elements will be supplied with adjustable feet H.16.
- In the order, specify whether positioned free-standing, supported or suspended.
- Always add the top.

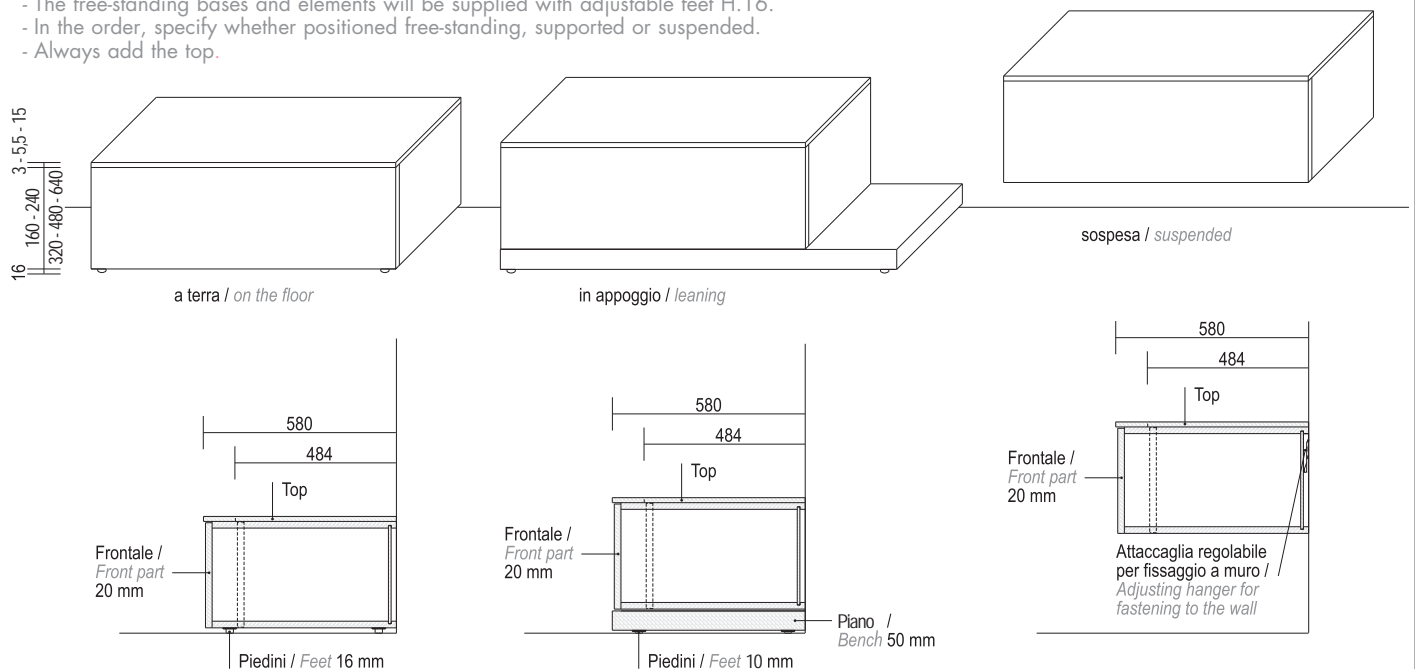

**N.B:** L'interno del mobile con frontale è in materico abbinato per le finiture rovere termotrattato e nodi, in laccato opaco in tinta per i laccati, le superfici UP e per le essenze rovere gesso, visone, cenere e castoro.

ATTENTION: The interior of the cabinet with a front has a matching textured finish for the heat-treated oak and oak knots finishes and matching matte lacquer for lacquers, UP surfaces, in addition to oak gesso, oak visone, oak cenere and oak castoro woods.

**CASSETTI E CESTONI | DRAWERS AND DEEP DRAWERS**

- Per basi ed elementi di larghezza superiore a 960 le scocche cassetto sono divise. - I cassetti / cestoni sono dotati di guide ad estrazione parziale; a richiesta e solo per P. 484, disponibili con maggiorazione guide ad estrazione totale (vedi pag. 117).
- For bases and elements wider than 960, the drawer bodies are divided. - Drawers / deep drawers are equipped with partial pull-out guides; on request and only for D. 484, total pull-out guides are available with a surcharge (see page 117).

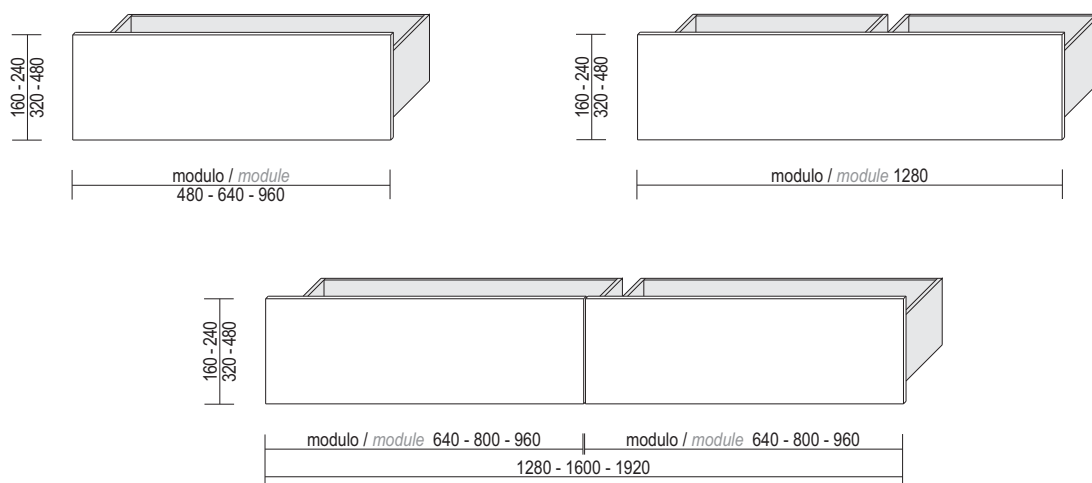

BASI A TERRA, IN APPOGGIO O SOSPESSE | FREE-STANDING, SUPPORTED OR SUSPENDED BASES

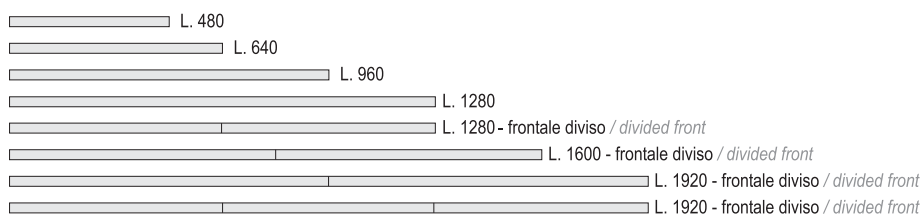
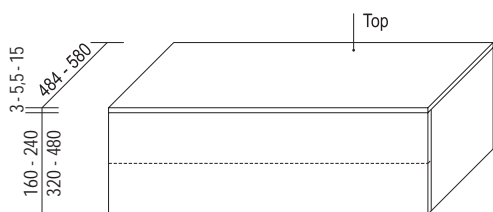

Braccetto a filo, solo con apertura verso il basso e con maniglia  
Wire hinge with a downwards opening only and a handle

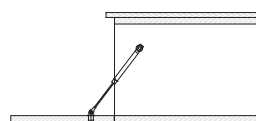
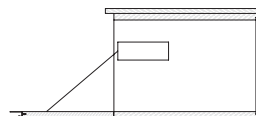

Braccetto con pistone  
Lid support with piston

ELEMENTI A TERRA, IN APPOGGIO O SOSPESI | FREE-STANDING, SUPPORTED OR SUSPENDED ELEMENTS

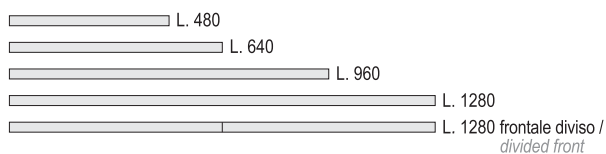
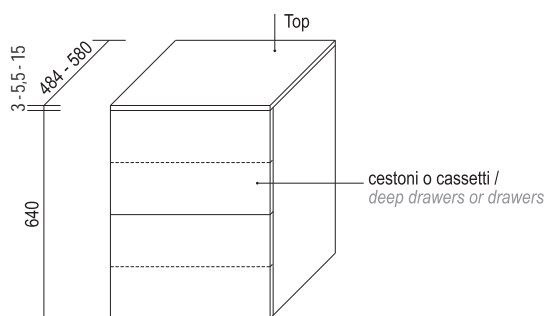
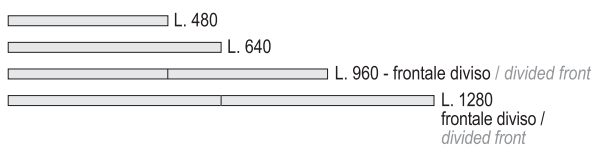
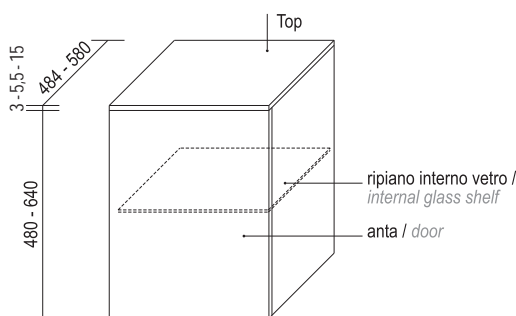

**PENSILI ANTA BATTENTE A TERRA O SOSPESI | FREE-STANDING OR SUSPENDED HINGED-DOOR WALL UNITS**

- Gli elementi a terra saranno forniti di piedini regolabili H.16.
- Top Sp.15 su richiesta.
- Nei pensili P. 384, per evitare il ribaltamento, si consiglia il fissaggio a muro anche quando l'elemento viene appoggiato a terra.
- The free-standing elements will be supplied with adjustable feet H.16.
- Top Th.15 only on request.
- For wall units d. 384, in order to prevent capsizing, we recommend the fastening on the wall, even in case of a free-standing element positioned on the floor.

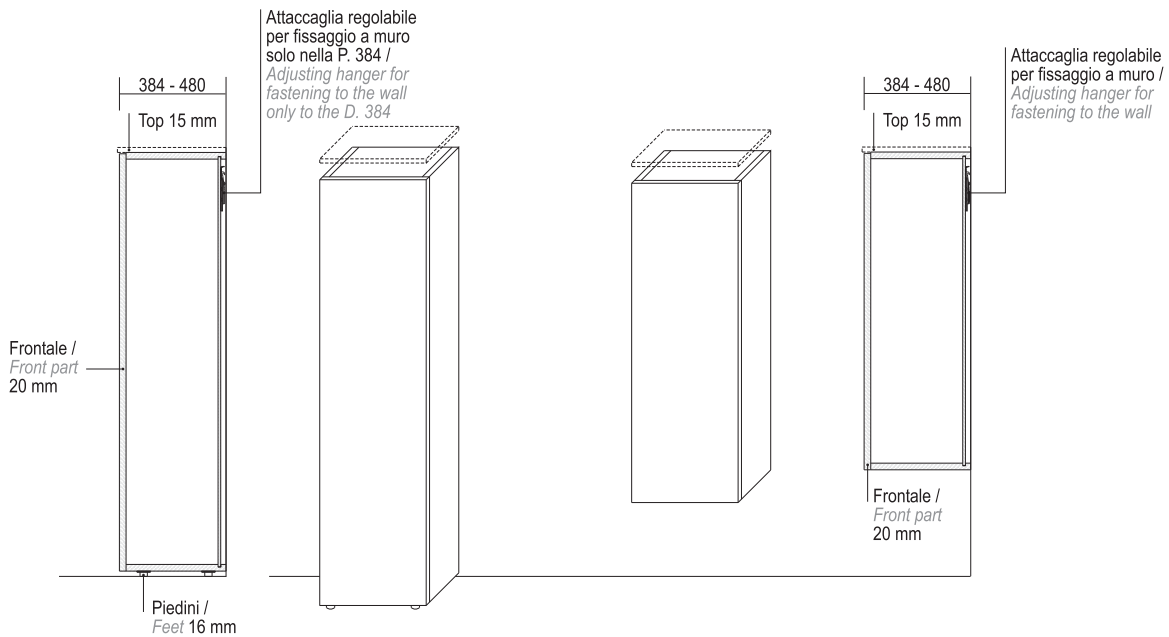

**/N.B:** L'interno del mobile e del vano a giorno è in materico abbinato per le finiture rovere termotrattato e nodi, in laccato opaco in tinta per i laccati, le superfici UP e per le essenze rovere gesso, visone, cenere e castoro.

ATTENTION: The interior of the cabinet with a front has a matching textured finish for the heat-treated oak and oak knots finishes and matching matte lacquer for lacquers, UP surfaces, in addition to oak gesso, oak visone, oak cenere and oak castoro woods.

**RIBALTE PENSILI | FLAP-DOOR WALL UNITS**

- Top Sp.15 su richiesta.
- Top Th.15 only on request.

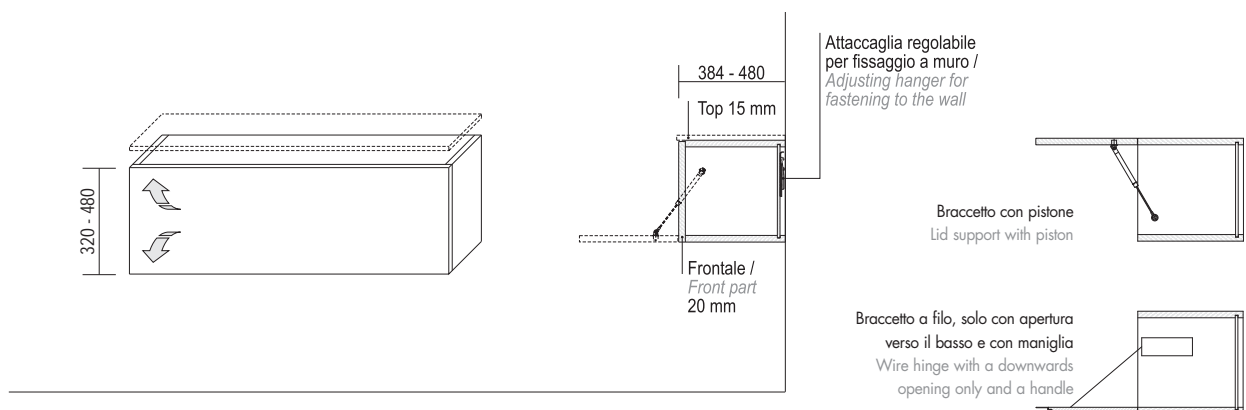

**PENSILI ANTA BATTENTE A TERRA O SOSPESI | FREE-STANDING OR SUSPENDED HINGED-DOOR WALL UNITS**

- I pensili hanno tutti i ripiani interni vetro ad eccezione di quelli con due ante che hanno ripiani vetro e ripiani fissi in legno indicati con \*.  
 - All the wall units are provided with internal glass shelves, except for those with 2 doors, which are supplied with glass and fixed wooden shelves marked by \*.

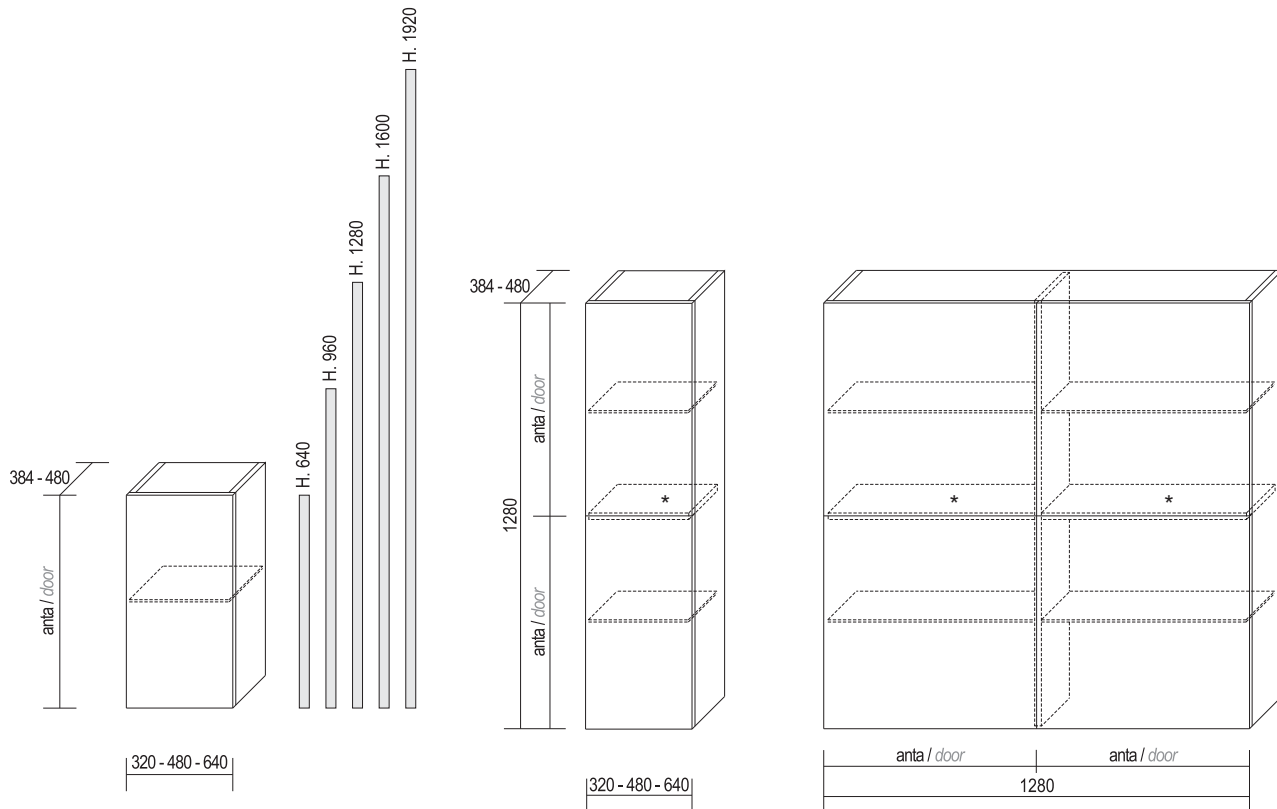

**RIBALTE PENSILI | FLAP-DOOR WALL UNITS**

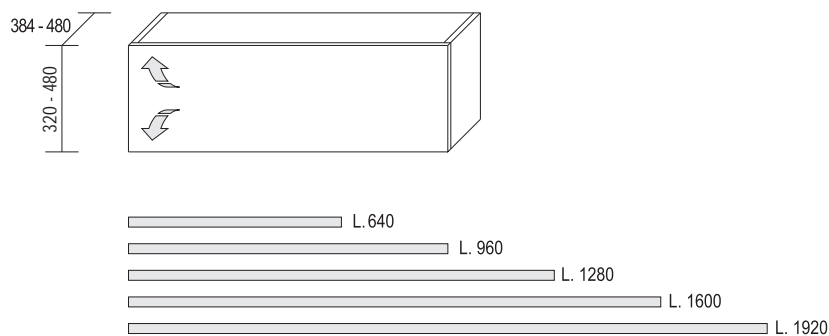



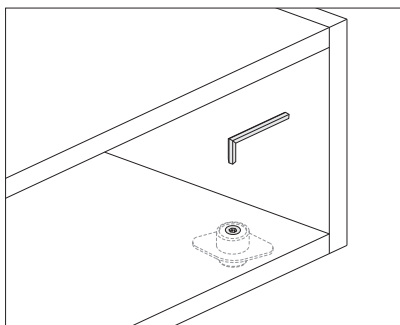

**STRUTTURE | STRUCTURES**

La struttura è realizzata in pannelli di particelle di legno E1 spessore 20 mm. Le finiture interne degli elementi sono: materico effetto essenza per gli impiallacciati rovere termotrattato e rovere nodi; per le altre essenze, i laccati opachi e lucidi, le superfici up, l'interno è laccato opaco in tinta.  
The structure is made of E1 wood particleboard panels with a thickness of 20 mm. The interior of the cabinet with a front has a matching textured finish for the heat-treated oak and oak knots finishes and matching matte lacquer for lacquers, UP surfaces, in addition to oak gesso, oak visone, oak cenere and oak castoro woods.

**REGOLAZIONE | ADJUSTMENT**

Per le basi, gli elementi e i pensili a terra, la regolazione per la messa a bolla avviene tramite piedini livellatori, posizionati sul fondo e regolabili con chiave a brugola.  
For free-standing base units, elements and wall units, the furniture is levelled using the levelling feet on the bottom. These can be adjusted with an Allen key.

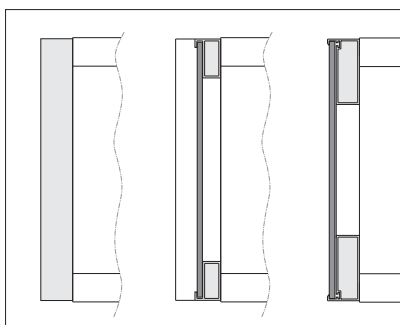

**FRONTALI LEGNO | WOODEN FRONTS**

Ante battenti, a ribalta, frontali cassetti e cestoni sono realizzati in pannelli di particelle di legno E1 spessore 20 mm, impiallacciati essenza oppure laccati opachi, lucidi o con superfici up. Sono di serie con apertura "push and pull" o a richiesta con maniglia.  
The hinged doors, flap-doors, drawer and deep drawer fronts are made of E1 wood particleboard panels with a thickness of 20 mm. They are wood-veneered, matt-lacquered, gloss-lacquered or have UP surfaces. They are fitted as standard with a "push and pull" opening and can be supplied on request with a handle.

**ANTE TELAIO SLIM | SLIM FRAME DOORS**

Sono composte da telai in alluminio finitura brown o bianco e da vetro sp. 4 mm. I vetri stopsol fumé e trasparenti lasciano intravedere il telaio sottostante. Le ante telaio sono battenti e a ribalta, disponibili solo con apertura "push and pull".  
These doors have a brown or white aluminium finish and 4 mm-thick glass. The underlying frame can be seen through the stopsol smoky and transparent glass. The frame doors can be hinged or flap-doors, with a "push and pull" opening.

**ANTE TELAIO UP | UP FRAME DOORS**

Sono composte da telai in alluminio finitura brown e da vetro trasparente grigio sp. 4 mm. Le ante telaio up sono solo battenti e disponibili con apertura tramite presa laterale sul telaio e chiusura ammortizzata.  
Sono utilizzabili esclusivamente su pensili senza l'impiego di top.  
These doors consist of aluminium frames with a brown or white finish and 4 mm-thick grey transparent glass. The UP frame doors are hinged and available with a side handle opening and a soft close. They can only be used on wall units with no top.

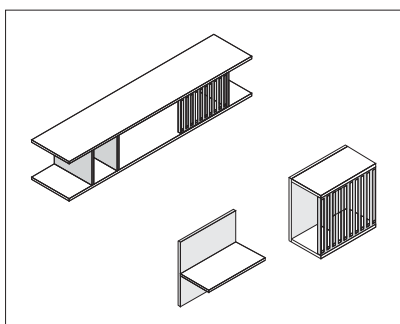

**PENSILI A GIORNO CON GRIGLIA | OPEN WALL UNIT WITH GRILL**

Gli elementi pensili orizzontali sono realizzati in pannelli di particelle di legno E1 sp. 15 mm.  
Gli elementi pensili L. 480 H. 480 sono realizzati in pannelli di particelle di legno E1 sp. 20 mm per lo schienale e sp. 15 mm per i ripiani. Sono impiallacciati essenza oppure laccati opachi, lucidi o con superfici up. La griglia è realizzata in metallo disponibile in finitura brown, bianco, titanio o ottone. Hanno un sistema di aggancio al muro dotato di regolazione in altezza.  
The horizontal wall units are made of 15 mm-thick E1 wood particleboard panels.  
The 480 x 480 (L x H) wall units are made of 20 mm-thick E1 wood particleboard panels for the back panel and 15 mm-thick panels for the shelves. They are wood-veneered, matt-lacquered, gloss-lacquered or have UP surfaces. The metal grill is available in a brown, white, titanium or brass finish. They have a height-adjustable wall mounting system.

The horizontal wall units are made of 15 mm-thick E1 wood particleboard panels.  
The 480 x 480 (L x H) wall units are made of 20 mm-thick E1 wood particleboard panels for the back panel and 15 mm-thick panels for the shelves. They are wood-veneered, matt-lacquered, gloss-lacquered or have UP surfaces. The metal grill is available in a brown, white, titanium or brass finish. They have a height-adjustable wall mounting system.

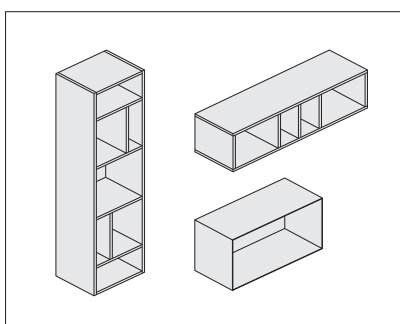

**ELEMENTI PENSILI A GIORNO | OPEN WALL UNITS**

Gli elementi a giorno sono realizzati in pannelli di particelle di legno E1 spessore 15 mm, impiallacciati essenza oppure laccati opachi, lucidi o con superfici up.  
Sono sempre agganciati a muro e sono disponibili in diverse dimensioni.  
The open wall units are made from 15 mm-thick E1 wood particleboard panels. They are either wood-veneered, matt-lacquered, gloss-lacquered or have UP surfaces.  
They are always fixed to the wall and are available in different sizes.

**ELEMENTI IN METALLO SOSPESI | SUSPENDED METAL ELEMENTS**

Gli elementi a giorno in metallo sospesi sono realizzati in metallo verniciato laccato opaco. La schiena è in pannelli di particelle di legno E1 spessore 12 mm, laccata opaca dello stesso colore della struttura.  
Sono sempre agganciati a muro e sono disponibili in diverse dimensioni.  
Suspended metal elements are made of lacquered matt painted metal. The back is made of E1 wood particleboard panels with a thickness of 12 mm, matt lacquered in the same colour as the structure.  
They are always fixed to the wall and are available in different sizes.

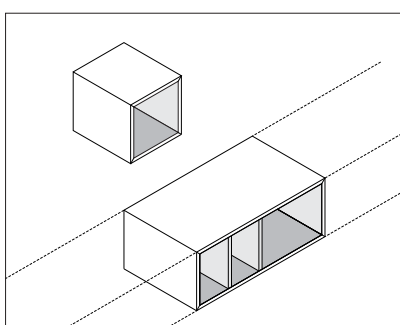

**CUBOTTI LEGNO | WOODEN CUBE-SHAPED ELEMENTS**

Sono realizzati in pannelli di particelle di legno E1 spessore 20 mm, impiallacciati essenza oppure laccati opachi, lucidi o con superfici up.  
Sono sempre a giorno, uniti a 45°. Sono disponibili in P. 458 per l'accostamento con basi a terra o sospese, P. 362 per l'accostamento ai pensili oppure possono essere impiegati come moduli singoli.  
È possibile l'inserimento di ripiani o divisioni legno sp. 20 mm.  
They are made from 20 mm-thick E1 wood particleboard panels and are wood-veneered, matt-lacquered, gloss-lacquered or have UP surfaces.  
They are always open and joined at 45°. A 458 mm-deep version is available for placing next to free-standing or suspended base units and a 362 mm-deep version is available for placing next to wall units. Alternatively, they can be used as individual modules. 20 mm-thick wooden shelves or dividers can be inserted.

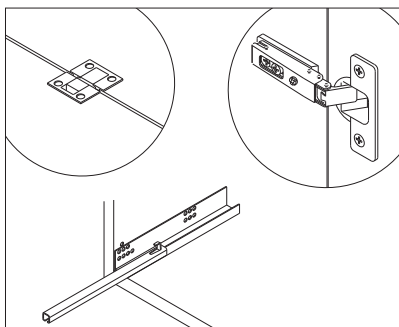

## SISTEMI DI APERTURA-CHIUSURA | OPENING AND CLOSING SYSTEMS

Nello SLIM sono previste tre tipologie di apertura: Anta battente - Ribalta - Cassetti/Cestoni. Le ante battenti hanno due sistemi di apertura, push o maniglia.

Le ante di serie sono previste con apertura push (con cricchetto a spinta). Le ante con maniglia sono dotate di cerniere con sistema di chiusura ammortizzato (soft). Le ribalte con apertura verso il basso hanno cerniere piatte, mentre le ribalte con apertura verso l'alto utilizzano le stesse cerniere delle ante battenti; apertura di serie push o con maniglia. I braccetti utilizzati sulle ribalte verso il basso sono: braccetti a pistone con apertura push pull o maniglia; braccetti a filo esclusivamente con maniglia. Per ribalta verso l'alto solo braccetti a pistone con apertura push pull o maniglia. I cassetti/cestoni in battuta di serie sono dotati di guide con apertura push e sincronizzatore che ne facilita l'apertura. I cassetti/cestoni con maniglia sono dotati di giude con sistema di chiusura ammortizzato (soft).

SLIM system is provided with 3 types of opening solutions: hinged door, flap door, drawers/deep drawers. Hinged doors are available with a push opening or a handle. Standard doors are supplied with "push" opening. Doors with handle are equipped with dampened hinges (soft closure). Flap doors with downward opening are available with flat hinges, while the ones with upward opening are designed with the same type of hinges used with hinged doors (standard push opening or handle). The lid supports used on the downwards-opening flap are: piston lid supports with a push and pull opening and a handle or wire hinges with a handle only. For the upwards-opening flap, only the piston lid support with a push and pull opening and a handle is available. Standard jutting drawers/deep drawers are supplied with push tracks and a synchronizing device which makes the opening easier. Drawers with handle are provided with dampened tracks (soft closure system).

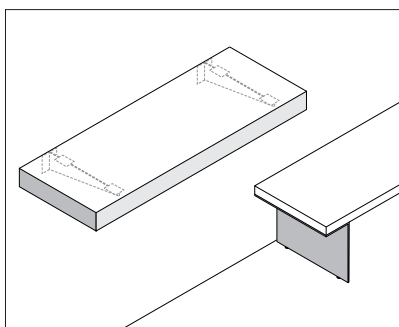

## PIANI A TERRA, IN APPOGGIO O SOSPESI SP. 50 / 100 | FREE-STANDING, SUPPORTED OR HANGING BENCHES TH. 50 / 100

I piani sp. 100, sono realizzati in pannelli di particelle di legno E1 spessore 20 mm, impiallacciati essenza oppure laccati opachi, lucidi o con superfici up. È uno scatolato in folding tre lati con un fondo di chiusura e il lato sul retro aperto; per questo motivo il piano sospeso non è studiato per essere posizionato in centro stanza ma sempre appoggiato alla parete. I piani sp. 50, sono realizzati in pannelli di particelle di legno E1 spessore 50 mm, impiallacciati essenza oppure laccati opachi, lucidi o con superfici up. Possono essere sospesi tramite staffe di supporto oppure posizionati a terra, con piedini di regolazione. La tenuta dei sistemi di fissaggio al muro è garantita dal corretto utilizzo dei tasselli, adeguati al tipo di parete (calcestruzzo, cartongesso, laterizio, ecc.), pertanto l'Azienda non fornisce alcun tipo di tassello e la responsabilità delle operazioni di montaggio è totalmente a carico del cliente.

The 100 mm-thick benches are made from 20 mm-thick E1 wood particleboard panels and are wood-veneered, matt-lacquered, gloss-lacquered or have UP surfaces. They are 3-sided folded boxes with a closed base and an open back; therefore they have not been designed to be placed in the middle of a room, they must always be set against a wall. The 50 mm-thick benches are made from 50 mm-thick E1 wood particleboard panels and are wood-veneered, matt-lacquered, gloss-lacquered or have UP surfaces. They can be suspended via the support brackets or placed on the ground using the adjustable feet. The right wall-compatible screw plugs (concrete, plasterboard, brick, etc.) must be used to ensure that the mounting system is secured to the wall. Therefore, the company does not supply any screw plugs and the customer is solely responsible for the assembly.

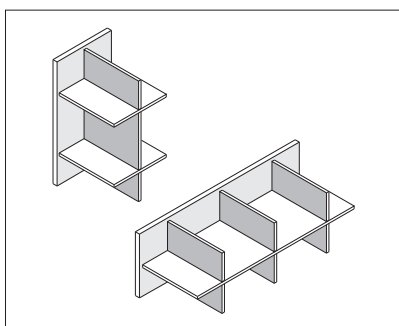

## SCAFFALATURE PENSILI | WALL SHELVING SYSTEM

Sono realizzate in pannelli di particelle di legno E1 sp. 25 mm per lo schienale e sp 15 mm per i ripiani e divisori, impiallacciati essenza oppure laccati opachi, lucidi o con superfici up. Hanno un sistema di aggancio al muro dotato di regolazione in altezza.

Sono componibili tra loro per creare giochi di modularità attraverso l'accostamento in orizzontale o verticale.

They are made of 25 mm-thick E1 wood particleboard panels for the back panel and 15 mm-thick panels for the shelves and dividers. They are also either wood-veneered, matt-lacquered, gloss-lacquered or have UP surfaces. They are provided with a hanging system which allows the fastening onto the wall and can be adjusted in height. They can be combined together in a horizontal or vertical position, in order to create different modular options.

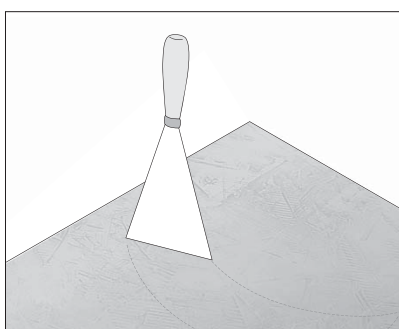

## SUPERFICI UP | UP SURFACE

Le finiture laccato effetto resina e laccato metallico sono realizzate con vernici a basso residuo secco e atossiche, il ciclo di verniciatura è ad acqua.

L'applicazione della finitura effetto resina avviene tramite spruzzo e spatolatura manuale ottenendo un effetto cemento in tridimensionale. La finitura laccato metallico avviene tramite spruzzo e carteggiatura manuale ottenendo un effetto simile al metallo spazzolato.

Essendo applicate manualmente si possono creare delle zone non uniformi, ma sicuramente di valore e di pregio, in quanto sono lavorazioni artigianali. Per la pulizia usare acqua e detergente (50/50).

The resin-effect lacquer finish is obtained using low dry residue and non-toxic paints, through a water-based painting cycle. The resin-effect finish is applied by manually using a spray and spatula to obtain a three-dimensional concrete effect. The metal lacquer finish is created by manually spraying and sanding, in order to obtain a brushed metal-effect. Since it is applied manually, there may be uneven areas, however this will only add to its value and prestige as these are handcrafted products. Use water and a cleaning agent to clean (50:50).



## VERNICI | PAINTS

Le vernici utilizzate sono a basso residuo secco e atossiche. Per le essenze e i laccati opachi il ciclo di verniciatura è ad acqua, mentre per i laccati lucidi a solvente. Il tipo di finitura per l'essenza è a poro aperto e la superficie subisce una lavorazione di spazzolatura. Le vernici all'acqua hanno il marchio Europeo LIFE perché permettono di ridurre le emissioni di solventi in atmosfera, sono contraddistinte dall'assenza di odori e tutelano la salute dell'operatore e dell'utilizzatore finale.

The paints employed are low-residue ones and atoxic. For the wood and lacquered finishes, water-borne paints are used. For the lacquered glossy finishes solvent-based paints are used. The wood finish is an open-pore one and the surface is submitted to a brushing process. Water-borne paints are identified by European LIFE trademark because they allow the reduction of the atmospheric emission of solvents and are characterized by the lack of scent, safeguarding the operator's and end consumer's health.

## TOLLERANZE | TOLERANCES

Le parti con finitura in essenza possono subire nel tempo variazioni di colore dovute alla luce, all'umidità e al passare del tempo. Esistono anche dei margini di tolleranza dovuti a variazioni di prodotto per le finiture laccate.

In caso di un completamento successivo dell'ordine, non si garantisce la perfetta eguaglianza di colori con la composizione originaria.

The parts with wood finish may change colour over time due to exposure to light and humidity as well as the passing of time. A certain allowance is due to product variation for lacquered finishes.

In case of a subsequent order, it's not possible to guarantee a perfect colour-matching with the original composition.

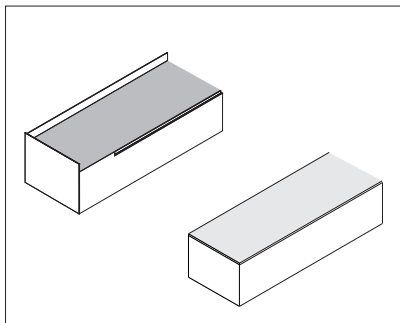

TOP | TOPS

Top legno: sono realizzati in pannelli di particelle di legno E1 sp. 15 mm, impiallacciati essenza oppure laccati opachi, lucidi o con superfici up. Top Laminam®: sono realizzati in lastre di sp. 5,5 mm con superficie in gres porcellanato, disponibili nelle finiture noir desir, orobico grigio e calacatta oro opachi o lucidati. Si tratta di un materiale dalla superficie compatta molto resistente al calore, al gelo, all'umidità, ai raggi uv, a funghi e muffe, alle macchie (vino, caffè, olio d'oliva, limone), a prodotti di pulizia e detergenti (le superfici lucidate presentano maggiore sensibilità rispetto alla superficie opaca anche se offrono prestazioni uguali o superiori rispetto ad altri materiali utilizzati in arredamento). Le operazioni di pulizia di questa superficie risultano semplici, efficaci e veloci grazie alla resistenza a graffi ed abrasioni.

Top metallo: sp. 3 mm disponibili in finitura brown, bianco, titanio e ottone. Possono essere utilizzati da soli o in abbinamento ad alzatina (con e senza luce) con fianchi in metallo.

Wooden top: made of 15 mm-thick E1 wood particleboard panels and they are either wood-veneered, matt-lacquered, gloss-lacquered or have UP surfaces.

Laminam® top: made of 5.5 mm-thick sheets with porcelain stoneware surfaces. Available in matt or gloss noir desir, orobico grigio and calacatta oro finishes. It is a compact surface material that is highly resistant to heat, frost, moisture, UV rays, fungus, mould, stains (wine, coffee, olive oil and lemon), cleaning products and detergents (the glossy surfaces are more sensitive than the matt surfaces, even if they offer the same or greater performance when compared to other materials used for furniture). This surface is simple, effective and quick to clean, due to its scratch and abrasion resistance.

Metal top: 3 mm thick and available in a brown, white, titanium or brass finish. They can be used on their own or in combination with a metal back panel (with or without an LED light) and side panels.

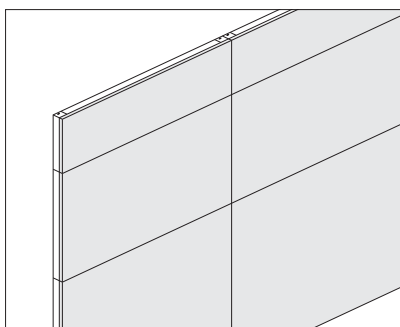

PANNELLI BOISERIE SP. 60 | BOISERIE PANELS TH. 60

I pannelli boiserie sono realizzati in pannelli di particelle di legno E1 spessore 20 mm, impiallacciati essenza oppure laccati opachi, lucidi o con superfici up. Sono completi di montanti e traversi posizionati sul retro sp. 40 mm, dotati di attaccaglia regolabile di aggancio al muro. Attrezzabili, a richiesta, con luci led posizionate sullo spessore 20 mm.

The wooden panelling is made from 20 mm-thick E1 wood particleboard panels and is wood-veneered, matt-lacquered, gloss-lacquered or has UP surfaces. They come with struts and crossbeams positioned at the back of the 40-mm thick panelling and are fitted with adjustable hangers for hooking to the wall. LED lights can be fitted onto the 20 mm-thick panelling on request.

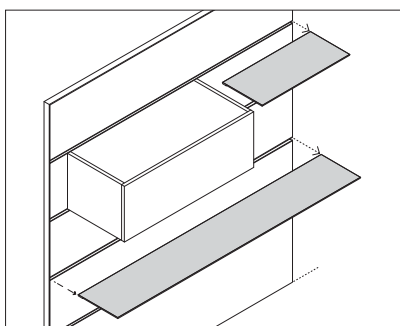

SCHIENALI ATTREZZABILI SP. 35 | ACCESSORIZED BACK PANELS TH. 35

Gli schienali attrezzabili sono realizzati in pannelli di particelle di legno E1 spessore 20 mm, impiallacciati essenza, rivestiti materico effetto pelle o termotrattato, oppure laccati opachi, lucidi o con superfici up. E' sconsigliato l'abbinamento del materico rovere termotrattato con l'essenza rovere termotrattato per evitare differenze di tonalità.

I profili sono in alluminio mentre le mensole sono in metallo, entrambi verniciati nelle finiture brown, bianco, titanio e ottone.

The accessorized back panels are made from 20 mm-thick E1 wood particleboard panels and can be wood-veneered, covered with a textured finish with leather effect or heat-treated material, matt-lacquered, gloss-lacquered or have UP surfaces.

We do not recommend combining a heat-treated oak material with a heat-treated oak finish, in order to avoid having different shades.

The profiles are made of aluminium, whilst the shelves are metal. Both are painted in either a brown, white, titanium or brass finish.

**EFFETTO RESINA:** L'interno degli elementi effetto resina è laccato opaco in tinta tortora, terracotta, light o dark grey.

**LACCATO METALLICO:** L'interno degli elementi in laccato metallico è laccato opaco in tinta titanio, nichel, piombo, ottone, bronzo.

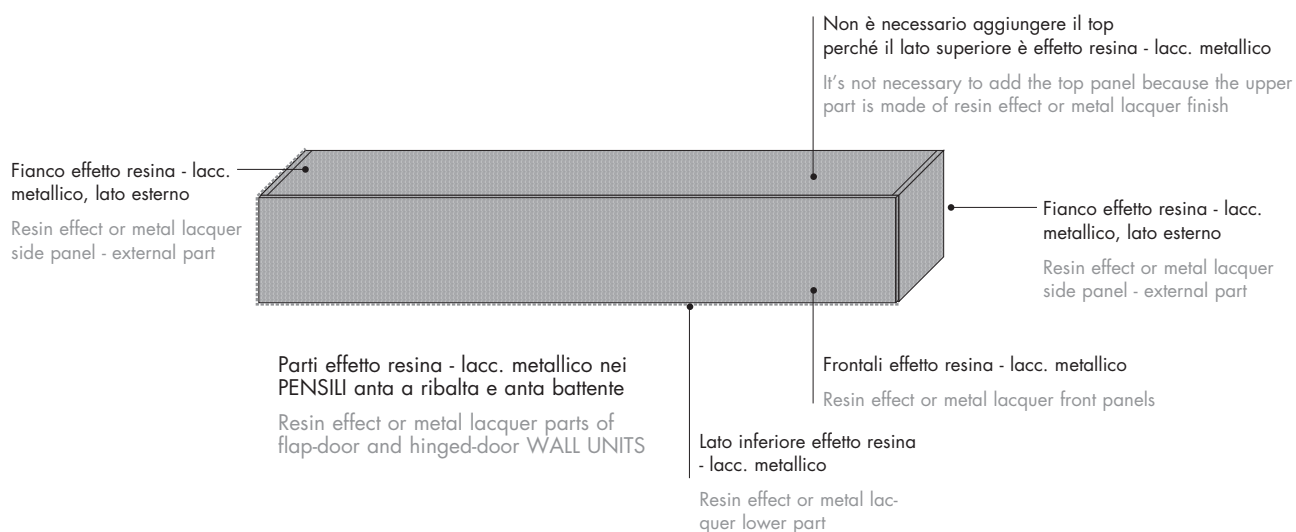
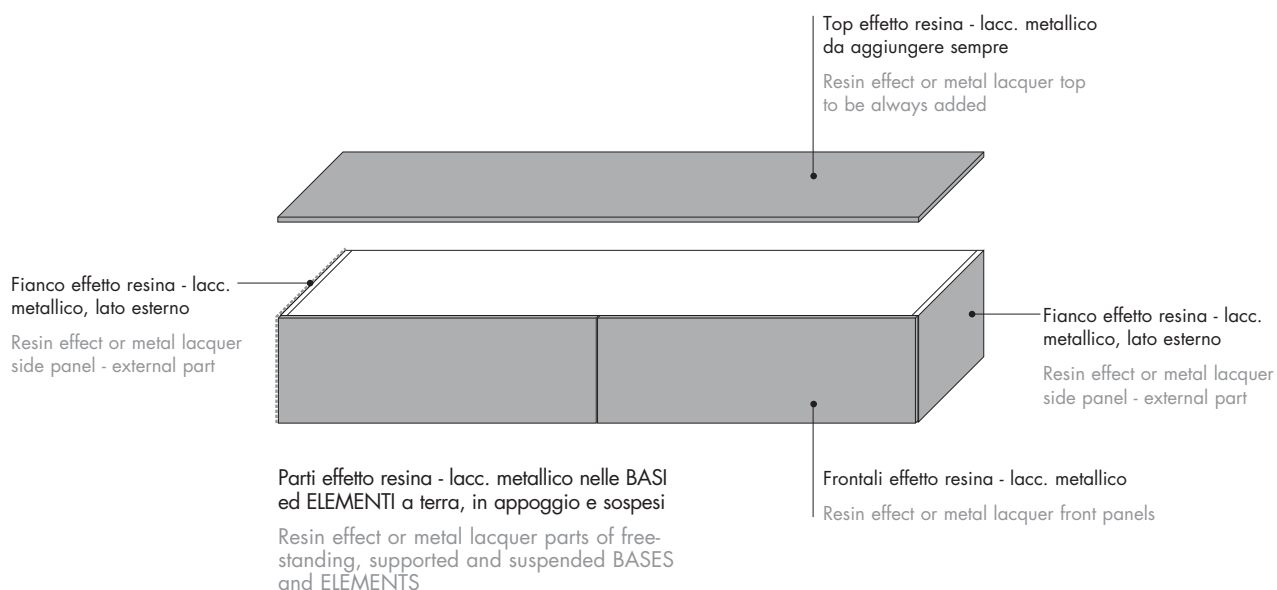

**RESIN EFFECT:** The interior of the resin-effect elements are matt lacquered in a light grey, dark grey, tortora or terracotta finish.

**METAL LACQUER:** The interior of the metal-lacquered elements have either a titanium, nickel, lead, brass or bronze-coloured mica matt lacquer.

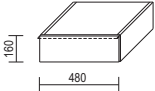
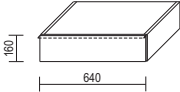
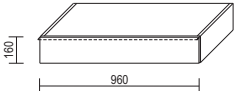
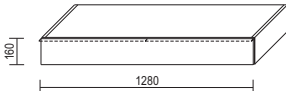
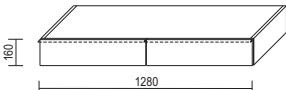
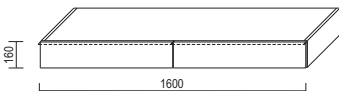
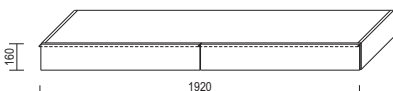

# BASI A TERRA O IN APPOGGIO | FREE-STANDING OR SUPPORTED BASES H.160

N.B: L'interno del mobile e del vano a giorno è in materico abbinato per il rovere termotrattato e nodi, in laccato opaco in tinta per i laccati, le superfici UP e per le essenze rovere gesso, visone, cenere e castoro

- Aggiungere sempre il top alle basi a pag.   Always add the top to the bases on page 72 - Apertura standard "push and pull"   Standard 'push and pull' opening - Specificare nell'ordine se a terra o in appoggio   In the order, specify whether positioned free-standing or supported			codice	lacc. opaco	essenza cat. 1	essenza cat. 2	rovere lacc.	lacc. lucido	
			code	matt lacq.	wood cat. 1	wood cat. 2	matt lacq. oak	glossy lacq.	
Base con 1 cassetto Base with 1 drawer 	VOLm <sup>3</sup>	Kg							
	0,054	14	P.   D. 480	SL1BC1420	<b>223</b>	<b>249</b>	<b>272</b>	<b>281</b>	<b>241</b>
	0,064	16	P.   D. 576	SL1BC1520	<b>235</b>	<b>263</b>	<b>289</b>	<b>299</b>	<b>258</b>
			Maniglia Slim   Slim handle Maniglia gola   Groove handle		<b>6</b> <b>32</b>	<b>6</b> <b>32</b>	<b>6</b> <b>32</b>	<b>6</b> <b>32</b>	<b>6</b> <b>32</b>
Base con 1 cassetto Base with 1 drawer 	VOLm <sup>3</sup>	Kg							
	0,071	17	P.   D. 480	SL1BC1430	<b>249</b>	<b>280</b>	<b>306</b>	<b>317</b>	<b>274</b>
	0,084	20	P.   D. 576	SL1BC1530	<b>267</b>	<b>295</b>	<b>325</b>	<b>336</b>	<b>291</b>
			Maniglia Slim   Slim handle Maniglia gola   Groove handle		<b>7</b> <b>35</b>	<b>7</b> <b>35</b>	<b>7</b> <b>35</b>	<b>7</b> <b>35</b>	<b>7</b> <b>35</b>
Base con 1 cassetto Base with 1 drawer 	VOLm <sup>3</sup>	Kg							
	0,104	23	P.   D. 480	SL1BC1450	<b>319</b>	<b>347</b>	<b>379</b>	<b>391</b>	<b>349</b>
	0,123	27	P.   D. 576	SL1BC1550	<b>337</b>	<b>365</b>	<b>400</b>	<b>412</b>	<b>370</b>
			Maniglia Slim   Slim handle Maniglia gola   Groove handle		<b>8</b> <b>39</b>	<b>8</b> <b>39</b>	<b>8</b> <b>39</b>	<b>8</b> <b>39</b>	<b>8</b> <b>39</b>
Base con 2 cassetti - frontale unico Base with 2 drawers - single front 	VOLm <sup>3</sup>	Kg							
	0,137	32	P.   D. 480	SL1BC1460	<b>435</b>	<b>465</b>	<b>506</b>	<b>523</b>	<b>468</b>
	0,163	37	P.   D. 576	SL1BC1560	<b>459</b>	<b>480</b>	<b>524</b>	<b>542</b>	<b>492</b>
			Maniglia Slim   Slim handle Maniglia gola   Groove handle		<b>12</b> <b>43</b>	<b>12</b> <b>43</b>	<b>12</b> <b>43</b>	<b>12</b> <b>43</b>	<b>12</b> <b>43</b>
Base con 2 cassetti Base with 2 drawers 	VOLm <sup>3</sup>	Kg							
	0,137	32	P.   D. 480	SL1BC2460	<b>430</b>	<b>465</b>	<b>507</b>	<b>525</b>	<b>467</b>
	0,163	37	P.   D. 576	SL1BC2560	<b>456</b>	<b>481</b>	<b>527</b>	<b>544</b>	<b>489</b>
			Maniglia Slim   Slim handle Maniglia gola   Groove handle		<b>14</b> <b>70</b>	<b>14</b> <b>70</b>	<b>14</b> <b>70</b>	<b>14</b> <b>70</b>	<b>14</b> <b>70</b>
Base con 2 cassetti Base with 2 drawers 	VOLm <sup>3</sup>	Kg							
	0,171	39	P.   D. 480	SL1BC2470	<b>519</b>	<b>551</b>	<b>599</b>	<b>619</b>	<b>554</b>
	0,202	45	P.   D. 576	SL1BC2570	<b>553</b>	<b>583</b>	<b>634</b>	<b>657</b>	<b>590</b>
			Maniglia Slim   Slim handle Maniglia gola   Groove handle		<b>14</b> <b>74</b>	<b>14</b> <b>74</b>	<b>14</b> <b>74</b>	<b>14</b> <b>74</b>	<b>14</b> <b>74</b>
Base con 2 cassetti Base with 2 drawers 	VOLm <sup>3</sup>	Kg							
	0,204	45	P.   D. 480	SL1BC2480	<b>566</b>	<b>601</b>	<b>652</b>	<b>673</b>	<b>613</b>
	0,241	50	P.   D. 576	SL1BC2580	<b>602</b>	<b>631</b>	<b>688</b>	<b>708</b>	<b>651</b>
			Maniglia Slim   Slim handle Maniglia gola   Groove handle		<b>16</b> <b>78</b>	<b>16</b> <b>78</b>	<b>16</b> <b>78</b>	<b>16</b> <b>78</b>	<b>16</b> <b>78</b>
Base con 3 cassetti Base with 3 drawers 	VOLm <sup>3</sup>	Kg							
	0,204	46	P.   D. 480	SL1BC3480	<b>633</b>	<b>675</b>	<b>733</b>	<b>758</b>	<b>681</b>
	0,241	51	P.   D. 576	SL1BC3580	<b>675</b>	<b>708</b>	<b>772</b>	<b>795</b>	<b>721</b>
			Maniglia Slim   Slim handle Maniglia gola   Groove handle		<b>21</b> <b>105</b>	<b>21</b> <b>105</b>	<b>21</b> <b>105</b>	<b>21</b> <b>105</b>	<b>21</b> <b>105</b>

Ulteriori combinazioni di aperture e finiture sono possibili utilizzando le scocche vuote a pag. | Additional finishes and opening combinations are possible using the empty bodies on page 59

# BASI A TERRA O IN APPOGGIO | FREE-STANDING OR SUPPORTED BASES H.160

N.B: The interior of the cabinet and open compartment has matching textured f. for heat-treated oak and oak knots finishes and matching matte lacquer for lacquers, UP surfaces, in addition to oak gesso, oak visone, oak cenere and oak castoro woods.

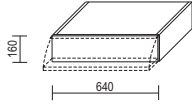
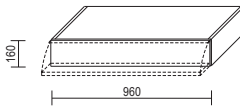
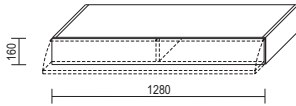
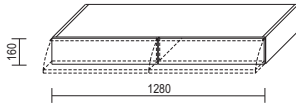
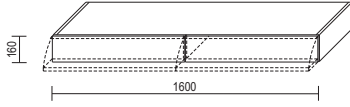
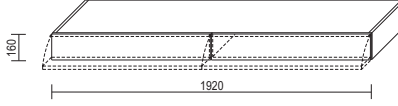
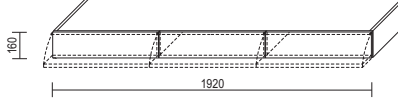
			codice code	lacc. opaco matt lacq.	essenza cat. 1 wood cat. 1	essenza cat. 2 wood cat. 2	rovere lacc. matt lacq. oak	lacc. lucido glossy lacq.	superfici UP UP surface
- Aggiungere sempre il top alle basi a pag.   Always add the top to the bases on page 72 - Apertura standard "push and pull"   Standard 'push and pull' opening - Specificare nell'ordine se a terra o in appoggio   In the order, specify whether positioned free-standing or supported									
<b>Base con 1 ribalta</b> Base with 1 flap-door									
	VOLm <sup>3</sup>	Kg							
	0,071	12	P.   D. 480	SL1BR1430	<b>235</b>	<b>268</b>	<b>290</b>	<b>298</b>	<b>262</b>
	0,084	15	P.   D. 576	SL1BR1530	<b>250</b>	<b>280</b>	<b>305</b>	<b>314</b>	<b>277</b>
			Maniglia Slim   Slim handle		16	16	16	16	16
			Maniglia gola   Groove handle		39	39	39	39	39
<b>Base con 1 ribalta</b> Base with 1 flap-door									
	VOLm <sup>3</sup>	Kg							
	0,104	17	P.   D. 480	SL1BR1450	<b>296</b>	<b>326</b>	<b>355</b>	<b>363</b>	<b>324</b>
	0,123	20	P.   D. 576	SL1BR1550	<b>311</b>	<b>341</b>	<b>371</b>	<b>380</b>	<b>342</b>
			Maniglia Slim   Slim handle		19	19	19	19	19
			Maniglia gola   Groove handle		46	46	46	46	46
<b>Base con 1 ribalta</b> Base with 1 flap-door									
	VOLm <sup>3</sup>	Kg							
	0,137	23	P.   D. 480	SL1BR1460	<b>357</b>	<b>390</b>	<b>417</b>	<b>430</b>	<b>393</b>
	0,163	27	P.   D. 576	SL1BR1560	<b>377</b>	<b>400</b>	<b>429</b>	<b>443</b>	<b>411</b>
			Maniglia Slim   Slim handle		30	30	30	30	30
			Maniglia gola   Groove handle		51	51	51	51	51
<b>Base con 2 ribalte</b> Base with 2 flap-doors									
	VOLm <sup>3</sup>	Kg							
	0,137	23	P.   D. 480	SL1BR2460	<b>402</b>	<b>441</b>	<b>475</b>	<b>487</b>	<b>443</b>
	0,163	27	P.   D. 576	SL1BR2560	<b>422</b>	<b>451</b>	<b>487</b>	<b>500</b>	<b>461</b>
			Maniglia Slim   Slim handle		32	32	32	32	32
			Maniglia gola   Groove handle		78	78	78	78	78
<b>Base con 2 ribalte</b> Base with 2 flap-doors									
	VOLm <sup>3</sup>	Kg							
	0,171	29	P.   D. 480	SL1BR2470	<b>473</b>	<b>513</b>	<b>553</b>	<b>567</b>	<b>514</b>
	0,202	33	P.   D. 576	SL1BR2570	<b>501</b>	<b>537</b>	<b>580</b>	<b>595</b>	<b>542</b>
			Maniglia Slim   Slim handle		36	36	36	36	36
			Maniglia gola   Groove handle		86	86	86	86	86
<b>Base con 2 ribalte</b> Base with 2 flap-doors									
	VOLm <sup>3</sup>	Kg							
	0,204	35	P.   D. 480	SL1BR2480	<b>520</b>	<b>559</b>	<b>604</b>	<b>617</b>	<b>563</b>
	0,241	37	P.   D. 576	SL1BR2580	<b>550</b>	<b>583</b>	<b>630</b>	<b>644</b>	<b>595</b>
			Maniglia Slim   Slim handle		38	38	38	38	38
			Maniglia gola   Groove handle		92	92	92	92	92
<b>Base con 3 ribalte</b> Base with 3 flap-doors									
	VOLm <sup>3</sup>	Kg							
	0,204	36	P.   D. 480	SL1BR3480	<b>591</b>	<b>639</b>	<b>685</b>	<b>701</b>	<b>645</b>
	0,241	38	P.   D. 576	SL1BR3580	<b>624</b>	<b>663</b>	<b>712</b>	<b>729</b>	<b>679</b>
			Maniglia Slim   Slim handle		48	48	48	48	48
			Maniglia gola   Groove handle		117	117	117	117	117

Ulteriori combinazioni di aperture e finiture sono possibili utilizzando le scocche vuote a pag. | Additional finishes and opening combinations are possible using the empty bodies on page 59

# BASI A TERRA O IN APPOGGIO | FREE-STANDING OR SUPPORTED BASES H.160

N.B: L'interno del mobile e del vano a giorno è in materico abbinato per il rovere termotrattato e nodi, in laccato opaco in tinta per i laccati, le superfici UP e per le essenze rovere gesso, visone, cenere e castoro

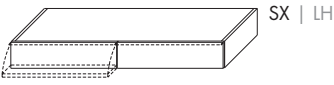
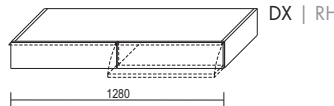
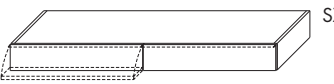
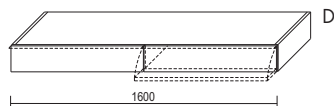
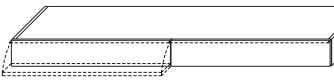
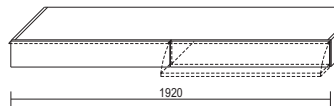
		codice code	lacc. opaco matt lacq.	essenza cat. 1 wood cat. 1	essenza cat. 2 wood cat. 2	rovere lacc. matt lacq. oak	lacc. lucido glossy lacq.	superfici UP UP surface
- Aggiungere sempre il top alle basi a pag.   Always add the top to the bases on page 72 - Apertura standard "push and pull"   Standard 'push and pull' opening - Specificare nell'ordine se a terra o in appoggio   In the order, specify whether positioned free-standing or supported								
<b>Base con 1 cassetto e 1 ribalta</b> Base with 1 drawer and 1 flap-door								
		VOLm <sup>3</sup> Kg	P.   D. 480					
		0,137 27	SX   LH	SL1BMS460	<b>416</b>	<b>453</b>	<b>491</b>	<b>506</b>
		VOLm <sup>3</sup> Kg	P.   D. 576					
		0,163 32	SX   LH	SL1BMS560	<b>439</b>	<b>466</b>	<b>507</b>	<b>522</b>
			Maniglia Slim   Slim handle	23	23	23	23	23
			Maniglia gola   Groove handle	74	74	74	74	74
<b>Base con 1 cassetto e 1 ribalta</b> Base with 1 drawer and 1 flap-door								
		VOLm <sup>3</sup> Kg	P.   D. 480					
		0,171 34	SX   LH	SL1BMS470	<b>496</b>	<b>532</b>	<b>576</b>	<b>593</b>
		VOLm <sup>3</sup> Kg	P.   D. 576					
		0,202 38,5	SX   LH	SL1BMS570	<b>527</b>	<b>560</b>	<b>607</b>	<b>626</b>
			Maniglia Slim   Slim handle	25	25	25	25	25
			Maniglia gola   Groove handle	80	80	80	80	80
<b>Base con 1 cassetto e 1 ribalta</b> Base with 1 drawer and 1 flap-door								
		VOLm <sup>3</sup> Kg	P.   D. 480					
		0,204 40,5	SX   LH	SL1BMS480	<b>543</b>	<b>580</b>	<b>628</b>	<b>645</b>
		VOLm <sup>3</sup> Kg	P.   D. 576					
		0,241 43,5	SX   LH	SL1BMS580	<b>576</b>	<b>607</b>	<b>659</b>	<b>676</b>
			Maniglia Slim   Slim handle	27	27	27	27	27
			Maniglia gola   Groove handle	85	85	85	85	85

Ulteriori combinazioni di aperture e finiture sono possibili utilizzando le scocche vuote a pag. | Additional finishes and opening combinations are possible using the empty bodies on page 59



# BASI A TERRA O IN APPOGGIO | FREE-STANDING OR SUPPORTED BASES H.240

N.B: The interior of the cabinet and open compartment has matching textured f. for heat-treated oak and oak knots finishes and matching matte lacquer for lacquers, UP surfaces, in addition to oak gesso, oak visone, oak cenere and oak castoro woods.

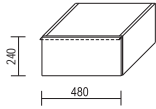
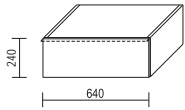
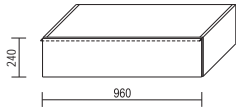
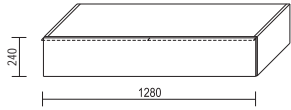
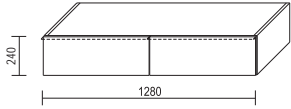
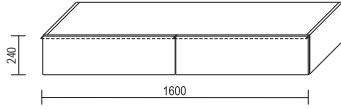
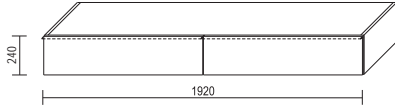
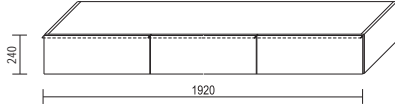
				codice code	lacc. opaco matt lacq.	essenza cat. 1 wood cat. 1	essenza cat. 2 wood cat. 2	rovere lacc. matt lacq. oak	lacc. lucido glossy lacq.	superfici UP UP surface	
- Aggiungere sempre il top alle basi a pag.   Always add the top to the bases on page 72 - Apertura standard "push and pull"   Standard 'push and pull' opening - Specificare nell'ordine se a terra o in appoggio   In the order, specify whether positioned free-standing or supported											
<b>Base con 1 cassetto</b> Base with 1 drawer											
		VOL.m <sup>3</sup> Kg 0,074 11 0,087 12		P.   D. 480 P.   D. 576 Maniglia Slim   Slim handle Maniglia gola   Groove handle		SL1BC1421	238	282	313	321	266
						SL1BC1521	253	297	330	339	287
							6	6	6	6	6
							32	32	32	32	32
<b>Base con 1 cassetto</b> Base with 1 drawer											
		VOL.m <sup>3</sup> Kg 0,095 13 0,112 14,5		P.   D. 480 P.   D. 576 Maniglia Slim   Slim handle Maniglia gola   Groove handle		SL1BC1431	271	318	351	360	303
						SL1BC1531	288	335	371	382	323
							7	7	7	7	7
							35	35	35	35	35
<b>Base con 1 cassetto</b> Base with 1 drawer											
		VOL.m <sup>3</sup> Kg 0,139 17 0,164 19,5		P.   D. 480 P.   D. 576 Maniglia Slim   Slim handle Maniglia gola   Groove handle		SL1BC1451	342	391	433	445	379
						SL1BC1551	364	407	451	463	404
							8	8	8	8	8
							39	39	39	39	39
<b>Base con 2 cassetti - frontale unico</b> Base with 2 drawers - single front											
		VOL.m <sup>3</sup> Kg 0,182 24,5 0,215 28		P.   D. 480 P.   D. 576 Maniglia Slim   Slim handle Maniglia gola   Groove handle		SL1BC1461	463	512	564	577	510
						SL1BC1561	487	530	585	602	534
							12	12	12	12	12
							43	43	43	43	43
<b>Base con 2 cassetti</b> Base with 2 drawers											
		VOL.m <sup>3</sup> Kg 0,182 24,5 0,215 28		P.   D. 480 P.   D. 576 Maniglia Slim   Slim handle Maniglia gola   Groove handle		SL1BC2461	464	516	568	581	512
						SL1BC2561	488	537	592	608	537
							14	14	14	14	14
							70	70	70	70	70
<b>Base con 2 cassetti</b> Base with 2 drawers											
		VOL.m <sup>3</sup> Kg 0,225 29 0,266 32,5		P.   D. 480 P.   D. 576 Maniglia Slim   Slim handle Maniglia gola   Groove handle		SL1BC2471	554	611	673	691	609
						SL1BC2571	590	645	706	725	647
							14	14	14	14	14
							74	74	74	74	74
<b>Base con 2 cassetti</b> Base with 2 drawers											
		VOL.m <sup>3</sup> Kg 0,268 33 0,317 37		P.   D. 480 P.   D. 576 Maniglia Slim   Slim handle Maniglia gola   Groove handle		SL1BC2481	608	668	736	754	669
						SL1BC2581	647	700	770	789	709
							16	16	16	16	16
							78	78	78	78	78
<b>Base con 3 cassetti</b> Base with 3 drawers											
		VOL.m <sup>3</sup> Kg 0,268 36 0,317 41		P.   D. 480 P.   D. 576 Maniglia Slim   Slim handle Maniglia gola   Groove handle		SL1BC3481	681	744	814	833	744
						SL1BC3581	723	782	856	876	789
							21	21	21	21	21
							105	105	105	105	105

Ulteriori combinazioni di aperture e finiture sono possibili utilizzando le scocche vuote a pag. | Additional finishes and opening combinations are possible using the empty bodies on page 59

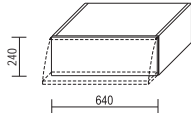
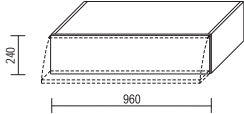
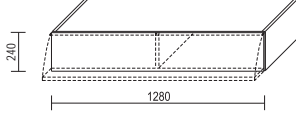
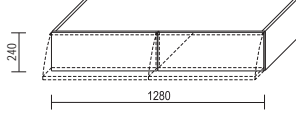
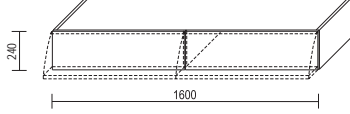
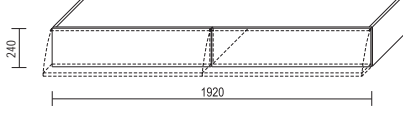
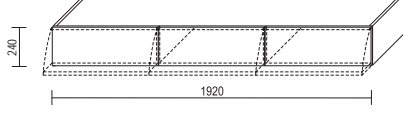

N.B: L'interno del mobile e del vano a giorno è in materico abbinato per il rovere termotrattato e nodi, in laccato opaco in tinta per i laccati, le superfici UP e per le essenze rovere gesso, visone, cenere e castoro

		codice	lacc. opaco	essenza cat. 1	essenza cat. 2	rovere lacc.	lacc. lucido		
		code	matt lacq.	wood cat. 1	wood cat. 2	matt lacq. oak	glossy lacq.		
							superfici UP		
							UP surface		
- Aggiungere sempre il top alle basi a pag.   Always add the top to the bases on page 72 - Apertura standard "push and pull"   Standard 'push and pull' opening - Specificare nell'ordine se a terra o in appoggio   In the order, specify whether positioned free-standing or supported - Possibile l'inserimento di braccetti a filo solo con maniglia, maggiorazione a pag. 118 Wire hinges can only be inserted in fronts with handles. Surcharge on page 118									
<b>Base con 1 ribalta</b> Base with 1 flap-door 		VOLm <sup>3</sup> Kg 0,095 10,5 0,112 12	P.   D. 480 P.   D. 576 Maniglia Slim   Slim handle Maniglia gola   Groove handle	SL1BR1431 SL1BR1531	<b>272</b> <b>287</b> 16 39	<b>325</b> <b>338</b> 16 39	<b>357</b> <b>372</b> 16 39	<b>368</b> <b>385</b> 16 39	<b>308</b> <b>325</b> 16 39
<b>Base con 1 ribalta</b> Base with 1 flap-door 		VOLm <sup>3</sup> Kg 0,139 14 0,164 16	P.   D. 480 P.   D. 576 Maniglia Slim   Slim handle Maniglia gola   Groove handle	SL1BR1451 SL1BR1551	<b>335</b> <b>353</b> 19 46	<b>388</b> <b>400</b> 19 46	<b>430</b> <b>444</b> 19 46	<b>444</b> <b>458</b> 19 46	<b>372</b> <b>394</b> 19 46
<b>Base con 1 ribalta</b> Base with 1 flap-door 		VOLm <sup>3</sup> Kg 0,182 19,5 0,215 22,5	P.   D. 480 P.   D. 576 Maniglia Slim   Slim handle Maniglia gola   Groove handle	SL1BR1461 SL1BR1561	<b>405</b> <b>425</b> 30 51	<b>458</b> <b>471</b> 30 51	<b>508</b> <b>522</b> 30 51	<b>522</b> <b>539</b> 30 51	<b>456</b> <b>475</b> 30 51
<b>Base con 2 ribalte</b> Base with 2 flap-doors 		VOLm <sup>3</sup> Kg 0,182 20 0,215 23	P.   D. 480 P.   D. 576 Maniglia Slim   Slim handle Maniglia gola   Groove handle	SL1BR2461 SL1BR2561	<b>466</b> <b>486</b> 32 78	<b>530</b> <b>543</b> 32 78	<b>580</b> <b>594</b> 32 78	<b>597</b> <b>614</b> 32 78	<b>522</b> <b>541</b> 32 78
<b>Base con 2 ribalte</b> Base with 2 flap-doors 		VOLm <sup>3</sup> Kg 0,225 23,5 0,266 26,5	P.   D. 480 P.   D. 576 Maniglia Slim   Slim handle Maniglia gola   Groove handle	SL1BR2471 SL1BR2571	<b>542</b> <b>572</b> 36 86	<b>611</b> <b>637</b> 36 86	<b>671</b> <b>698</b> 36 86	<b>689</b> <b>717</b> 36 86	<b>603</b> <b>635</b> 36 86
<b>Base con 2 ribalte</b> Base with 2 flap-doors 		VOLm <sup>3</sup> Kg 0,268 26,5 0,317 30	P.   D. 480 P.   D. 576 Maniglia Slim   Slim handle Maniglia gola   Groove handle	SL1BR2481 SL1BR2581	<b>594</b> <b>625</b> 38 92	<b>662</b> <b>686</b> 38 92	<b>730</b> <b>756</b> 38 92	<b>752</b> <b>779</b> 38 92	<b>655</b> <b>689</b> 38 92
<b>Base con 3 ribalte</b> Base with 3 flap-doors 		VOLm <sup>3</sup> Kg 0,268 29 0,317 33	P.   D. 480 P.   D. 576 Maniglia Slim   Slim handle Maniglia gola   Groove handle	SL1BR3481 SL1BR3581	<b>684</b> <b>720</b> 48 117	<b>765</b> <b>791</b> 48 117	<b>832</b> <b>859</b> 48 117	<b>857</b> <b>885</b> 48 117	<b>759</b> <b>795</b> 48 117

Ulteriori combinazioni di aperture e finiture sono possibili utilizzando le scocche vuote a pag. | Additional finishes and opening combinations are possible using the empty bodies on page 59

# BASI A TERRA O IN APPOGGIO | FREE-STANDING OR SUPPORTED BASES H.240

N.B: The interior of the cabinet and open compartment has matching textured f. for heat-treated oak and oak knots finishes and matching matte lacquer for lacquers, UP surfaces, in addition to oak gesso, oak visone, oak cenere and oak castoro woods.

		codice code	lacc. opaco matt lacq.	essenza cat. 1 wood cat. 1	essenza cat. 2 wood cat. 2	rovere lacc. matt lacq. oak	lacc. lucido glossy lacq.	
- Aggiungere sempre il top alle basi a pag.   Always add the top to the bases on page 72 - Apertura standard "push and pull"   Standard 'push and pull' opening - Specificare nell'ordine se a terra o in appoggio   In the order, specify whether positioned free-standing or supported - Possibile l'inserimento di braccetti a filo solo con maniglia, maggiorazione a pag. 118 Wire hinges can only be inserted in fronts with handles. Surcharge on page 118							superfici UP UP surface	
Base con 1 cassetto e 1 ribalta Base with 1 drawer and 1 flap-door								
	VOLm³ Kg	P.   D. 480						
	0,182 22	SX   LH	SL1BMS461	465	523	574	589	517
		DX   RH	SL1BMD461	465	523	574	589	517
	VOLm³ Kg	P.   D. 576						
	0,215 24,5	SX   LH	SL1BMS561	487	540	593	611	539
		DX   RH	SL1BMD561	487	540	593	611	539
	Maniglia Slim   Slim handle		23	23	23	23	23	
	Maniglia gola   Groove handle		74	74	74	74	74	
Base con 1 cassetto e 1 ribalta Base with 1 drawer and 1 flap-door								
	VOLm³ Kg	P.   D. 480						
	0,225 26	SX   LH	SL1BMS471	548	611	672	690	606
		DX   RH	SL1BMD471	548	611	672	690	606
	VOLm³ Kg	P.   D. 576						
	0,266 29,5	SX   LH	SL1BMS571	581	641	702	721	641
		DX   RH	SL1BMD571	581	641	702	721	641
	Maniglia Slim   Slim handle		25	25	25	25	25	
	Maniglia gola   Groove handle		80	80	80	80	80	
Base con 1 cassetto e 1 ribalta Base with 1 drawer and 1 flap-door								
	VOLm³ Kg	P.   D. 480						
	0,268 30	SX   LH	SL1BMS481	601	665	733	753	662
		DX   RH	SL1BMD481	601	665	733	753	662
	VOLm³ Kg	P.   D. 576						
	0,317 33,5	SX   LH	SL1BMS581	636	693	763	784	699
		DX   RH	SL1BMD581	636	693	763	784	699
	Maniglia Slim   Slim handle		27	27	27	27	27	
	Maniglia gola   Groove handle		85	85	85	85	85	

Ulteriori combinazioni di aperture e finiture sono possibili utilizzando le scocche vuote a pag. | Additional finishes and opening combinations are possible using the empty bodies on page 59

# BASI A TERRA O IN APPOGGIO | FREE-STANDING OR SUPPORTED BASES H.320

N.B: L'interno del mobile e del vano a giorno è in materico abbinato per il rovere termotrattato e nodi, in laccato opaco in tinta per i laccati, le superfici UP e per le essenze rovere gesso, visone, cenere e castoro

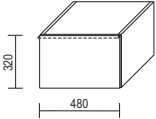
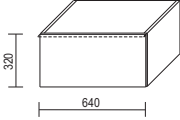
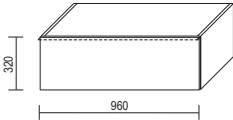
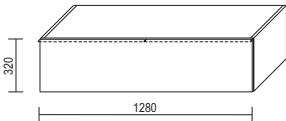
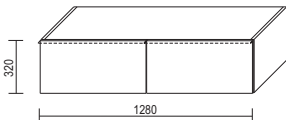
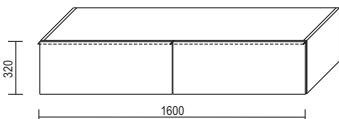
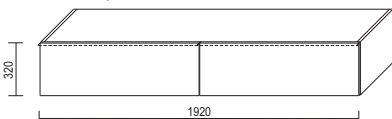
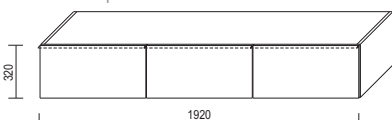
- Aggiungere sempre il top alle basi a pag.   Always add the top to the bases on page 72 - Apertura standard "push and pull"   Standard 'push and pull' opening - Specificare nell'ordine se a terra o in appoggio   In the order, specify whether positioned free-standing or supported		codice	lacc. opaco	essenza cat. 1	essenza cat. 2	rovere lacc.	lacc. lucido	
		code	matt lacq.	wood cat. 1	wood cat. 2	matt lacq. oak	glossy lacq.	
							superfici UP UP surface	
Base con 1 cestone Base with 1 deep drawer 	VOLm <sup>3</sup> Kg							
	0,097 17	P.   D. 480	SL1BC1422	<b>255</b>	<b>290</b>	<b>330</b>	<b>341</b>	<b>292</b>
	0,115 21	P.   D. 576	SL1BC1522	<b>272</b>	<b>315</b>	<b>353</b>	<b>365</b>	<b>313</b>
		Maniglia Slim   Slim handle Maniglia gola   Groove handle		<b>6</b> <b>32</b>	<b>6</b> <b>32</b>	<b>6</b> <b>32</b>	<b>6</b> <b>32</b>	<b>6</b> <b>32</b>
Base con 1 cestone Base with 1 deep drawer 	VOLm <sup>3</sup> Kg							
	0,127 21,5	P.   D. 480	SL1BC1432	<b>292</b>	<b>332</b>	<b>371</b>	<b>384</b>	<b>332</b>
	0,151 25,5	P.   D. 576	SL1BC1532	<b>310</b>	<b>354</b>	<b>398</b>	<b>410</b>	<b>355</b>
		Maniglia Slim   Slim handle Maniglia gola   Groove handle		<b>7</b> <b>35</b>	<b>7</b> <b>35</b>	<b>7</b> <b>35</b>	<b>7</b> <b>35</b>	<b>7</b> <b>35</b>
Base con 1 cestone Base with 1 deep drawer 	VOLm <sup>3</sup> Kg							
	0,187 29	P.   D. 480	SL1BC1452	<b>365</b>	<b>401</b>	<b>454</b>	<b>470</b>	<b>410</b>
	0,222 33	P.   D. 576	SL1BC1552	<b>389</b>	<b>428</b>	<b>478</b>	<b>495</b>	<b>438</b>
		Maniglia Slim   Slim handle Maniglia gola   Groove handle		<b>8</b> <b>39</b>	<b>8</b> <b>39</b>	<b>8</b> <b>39</b>	<b>8</b> <b>39</b>	<b>8</b> <b>39</b>
Base con 2 cestoni - frontale unico Base with 2 deep drawers - single front 	VOLm <sup>3</sup> Kg							
	0,247 42	P.   D. 480	SL1BC1462	<b>493</b>	<b>520</b>	<b>580</b>	<b>601</b>	<b>552</b>
	0,293 48,5	P.   D. 576	SL1BC1562	<b>517</b>	<b>552</b>	<b>614</b>	<b>634</b>	<b>580</b>
		Maniglia Slim   Slim handle Maniglia gola   Groove handle		<b>12</b> <b>43</b>	<b>12</b> <b>43</b>	<b>12</b> <b>43</b>	<b>12</b> <b>43</b>	<b>12</b> <b>43</b>
Base con 2 cestoni Base with 2 deep drawers 	VOLm <sup>3</sup> Kg							
	0,247 42	P.   D. 480	SL1BC2462	<b>497</b>	<b>529</b>	<b>589</b>	<b>608</b>	<b>559</b>
	0,293 48,5	P.   D. 576	SL1BC2562	<b>519</b>	<b>560</b>	<b>625</b>	<b>644</b>	<b>587</b>
		Maniglia Slim   Slim handle Maniglia gola   Groove handle		<b>14</b> <b>70</b>	<b>14</b> <b>70</b>	<b>14</b> <b>70</b>	<b>14</b> <b>70</b>	<b>14</b> <b>70</b>
Base con 2 cestoni Base with 2 deep drawers 	VOLm <sup>3</sup> Kg							
	0,307 49	P.   D. 480	SL1BC2472	<b>591</b>	<b>627</b>	<b>699</b>	<b>722</b>	<b>662</b>
	0,364 56	P.   D. 576	SL1BC2572	<b>632</b>	<b>674</b>	<b>747</b>	<b>769</b>	<b>705</b>
		Maniglia Slim   Slim handle Maniglia gola   Groove handle		<b>14</b> <b>74</b>	<b>14</b> <b>74</b>	<b>14</b> <b>74</b>	<b>14</b> <b>74</b>	<b>14</b> <b>74</b>
Base con 2 cestoni Base with 2 deep drawers 	VOLm <sup>3</sup> Kg							
	0,367 56	P.   D. 480	SL1BC2482	<b>648</b>	<b>680</b>	<b>760</b>	<b>785</b>	<b>727</b>
	0,435 64	P.   D. 576	SL1BC2582	<b>690</b>	<b>732</b>	<b>813</b>	<b>839</b>	<b>771</b>
		Maniglia Slim   Slim handle Maniglia gola   Groove handle		<b>16</b> <b>78</b>	<b>16</b> <b>78</b>	<b>16</b> <b>78</b>	<b>16</b> <b>78</b>	<b>16</b> <b>78</b>
Base con 3 cestoni Base with 3 deep drawers 	VOLm <sup>3</sup> Kg							
	0,367 61,5	P.   D. 480	SL1BC3482	<b>727</b>	<b>759</b>	<b>839</b>	<b>865</b>	<b>809</b>
	0,435 71,5	P.   D. 576	SL1BC3582	<b>770</b>	<b>809</b>	<b>895</b>	<b>920</b>	<b>859</b>
		Maniglia Slim   Slim handle Maniglia gola   Groove handle		<b>21</b> <b>105</b>	<b>21</b> <b>105</b>	<b>21</b> <b>105</b>	<b>21</b> <b>105</b>	<b>21</b> <b>105</b>

Ulteriori combinazioni di aperture e finiture sono possibili utilizzando le scocche vuote a pag. | Additional finishes and opening combinations are possible using the empty bodies on page 59

# BASI A TERRA O IN APPOGGIO | FREE-STANDING OR SUPPORTED BASES H.320

N.B: The interior of the cabinet and open compartment has matching textured f. for heat-treated oak and oak knots finishes and matching matte lacquer for lacquers, UP surfaces, in addition to oak gesso, oak visone, oak cenere and oak castoro woods.

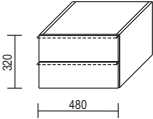
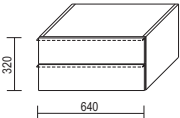
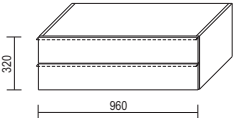
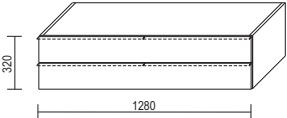
- Aggiungere sempre il top alle basi a pag.   Always add the top to the bases on page 72 - Apertura standard "push and pull"   Standard 'push and pull' opening - Specificare nell'ordine se a terra o in appoggio   In the order, specify whether positioned free-standing or supported - Non è possibile l'abbinamento di cassetti con maniglia insieme a cassetti apertura "push and pull"   Drawers with handles cannot be combined with "push and pull"-opening drawers		codice code	lacc. opaco matt lacq.	essenza cat. 1 wood cat. 1	essenza cat. 2 wood cat. 2	rovere lacc. matt lacq. oak	lacc. lucido glossy lacq.	
							superfici UP UP surface	
Base con 2 cassetti Base with 2 drawers								
	VOLm <sup>3</sup> Kg							
	0,097 20	P.   D. 480	SL1BT2422	<b>322</b>	<b>362</b>	<b>409</b>	<b>424</b>	<b>357</b>
	0,115 23,5	P.   D. 576	SL1BT2522	<b>340</b>	<b>385</b>	<b>432</b>	<b>449</b>	<b>380</b>
		Maniglia Slim   Slim handle Maniglia gola   Groove handle		12 64	12 64	12 64	12 64	12 64
Base con 2 cassetti Base with 2 drawers								
	VOLm <sup>3</sup> Kg							
	0,127 24,5	P.   D. 480	SL1BT2432	<b>366</b>	<b>413</b>	<b>465</b>	<b>485</b>	<b>409</b>
	0,151 29	P.   D. 576	SL1BT2532	<b>388</b>	<b>437</b>	<b>493</b>	<b>511</b>	<b>432</b>
		Maniglia Slim   Slim handle Maniglia gola   Groove handle		14 70	14 70	14 70	14 70	14 70
Base con 2 cassetti Base with 2 drawers								
	VOLm <sup>3</sup> Kg							
	0,187 32,5	P.   D. 480	SL1BT2452	<b>455</b>	<b>498</b>	<b>562</b>	<b>586</b>	<b>505</b>
	0,222 36,5	P.   D. 576	SL1BT2552	<b>481</b>	<b>523</b>	<b>588</b>	<b>611</b>	<b>535</b>
		Maniglia Slim   Slim handle Maniglia gola   Groove handle		16 78	16 78	16 78	16 78	16 78
Base con 4 cassetti - frontale unico Base with 4 drawers - single front								
	VOLm <sup>3</sup> Kg							
	0,247 51	P.   D. 480	SL1BT2462	<b>655</b>	<b>691</b>	<b>775</b>	<b>806</b>	<b>715</b>
	0,293 60	P.   D. 576	SL1BT2562	<b>681</b>	<b>724</b>	<b>809</b>	<b>842</b>	<b>747</b>
		Maniglia Slim   Slim handle Maniglia gola   Groove handle		24 86	24 86	24 86	24 86	24 86

Ulteriori combinazioni di aperture e finiture sono possibili utilizzando le scocche vuote a pag. | Additional finishes and opening combinations are possible using the empty bodies on page 59

# BASI A TERRA O IN APPOGGIO | FREE-STANDING OR SUPPORTED BASES H.320

N.B: L'interno del mobile e del vano a giorno è in materico abbinato per il rovere termotrattato e nodi, in laccato opaco in tinta per i laccati, le superfici UP e per le essenze rovere gesso, visone, cenere e castoro

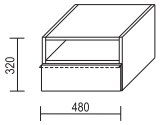
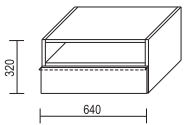
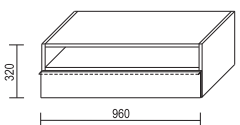
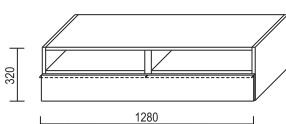
- Aggiungere sempre il top alle basi a pag.   Always add the top to the bases on page 72 - Apertura standard "push and pull"   Standard 'push and pull' opening - Specificare nell'ordine se a terra o in appoggio   In the order, specify whether positioned free-standing or supported		codice	lacc. opaco	essenza cat. 1	essenza cat. 2	rovere lacc.	lacc. lucido	
		code	matt lacq.	wood cat. 1	wood cat. 2	matt lacq. oak	glossy lacq.	
							superfici UP UP surface	
Base con 1 cassetto e 1 vano a giorno Base with 1 drawer and 1 open compartment								
	VOLm <sup>3</sup> Kg							
	0,097 16,2	P.   D. 480	SL1BT1422	<b>294</b>	<b>310</b>	<b>359</b>	<b>369</b>	<b>322</b>
	0,115 19,2	P.   D. 576	SL1BT1522	<b>317</b>	<b>334</b>	<b>386</b>	<b>398</b>	<b>350</b>
		Maniglia Slim   Slim handle Maniglia gola   Groove handle		<b>6</b> <b>32</b>	<b>6</b> <b>32</b>	<b>6</b> <b>32</b>	<b>6</b> <b>32</b>	<b>6</b> <b>32</b>
Base con 1 cassetto e 1 vano a giorno Base with 1 drawer and 1 open compartment								
	VOLm <sup>3</sup> Kg							
	0,127 19,8	P.   D. 480	SL1BT1432	<b>336</b>	<b>348</b>	<b>405</b>	<b>418</b>	<b>368</b>
	0,151 23,8	P.   D. 576	SL1BT1532	<b>361</b>	<b>373</b>	<b>435</b>	<b>447</b>	<b>395</b>
		Maniglia Slim   Slim handle Maniglia gola   Groove handle		<b>7</b> <b>35</b>	<b>7</b> <b>35</b>	<b>7</b> <b>35</b>	<b>7</b> <b>35</b>	<b>7</b> <b>35</b>
Base con 1 cassetto e 1 vano a giorno Base with 1 drawer and 1 open compartment								
	VOLm <sup>3</sup> Kg							
	0,187 26	P.   D. 480	SL1BT1452	<b>424</b>	<b>424</b>	<b>493</b>	<b>508</b>	<b>458</b>
	0,222 29,1	P.   D. 576	SL1BT1552	<b>456</b>	<b>451</b>	<b>523</b>	<b>538</b>	<b>494</b>
		Maniglia Slim   Slim handle Maniglia gola   Groove handle		<b>8</b> <b>39</b>	<b>8</b> <b>39</b>	<b>8</b> <b>39</b>	<b>8</b> <b>39</b>	<b>8</b> <b>39</b>
Base con 2 cassetti (frontale unico) e 2 vani a giorno Base with 2 drawers (single front) and 2 open compartments								
	VOLm <sup>3</sup> Kg							
	0,247 42,2	P.   D. 480	SL1BT1462	<b>590</b>	<b>561</b>	<b>656</b>	<b>674</b>	<b>632</b>
	0,293 50	P.   D. 576	SL1BT1562	<b>624</b>	<b>597</b>	<b>696</b>	<b>716</b>	<b>670</b>
		Maniglia Slim   Slim handle Maniglia gola   Groove handle		<b>12</b> <b>43</b>	<b>12</b> <b>43</b>	<b>12</b> <b>43</b>	<b>12</b> <b>43</b>	<b>12</b> <b>43</b>

Ulteriori combinazioni di aperture e finiture sono possibili utilizzando le scocche vuote a pag. | Additional finishes and opening combinations are possible using the empty bodies on page 59

N.B: The interior of the cabinet and open compartment has matching textured f. for heat-treated oak and oak knots finishes and matching matte lacquer for lacquers, UP surfaces, in addition to oak gesso, oak visone, oak cenere and oak castoro woods.

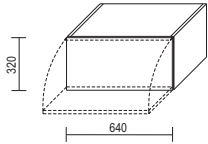
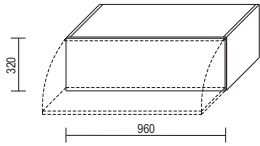
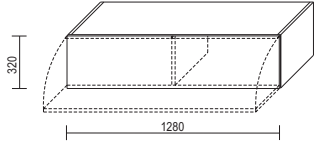
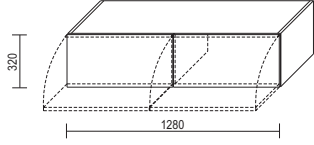
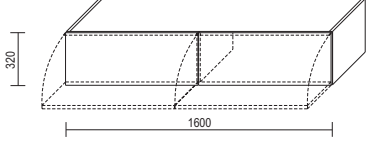
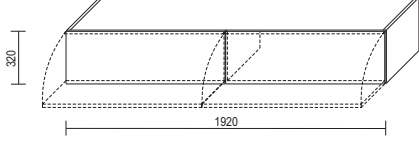
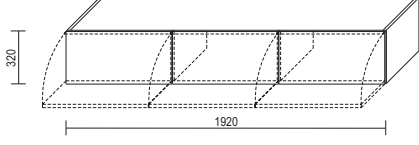
				codice code	lacc. opaco matt lacq.	essenza cat. 1 wood cat. 1	essenza cat. 2 wood cat. 2	rovere lacc. matt lacq. oak	lacc. lucido glossy lacq.	superfici UP UP surface
- Aggiungere sempre il top alle basi a pag.   Always add the top to the bases on page 72 - Apertura standard "push and pull"   Standard 'push and pull' opening - Specificare nell'ordine se a terra o in appoggio   In the order, specify whether positioned free-standing or supported - Possibile l'inserimento di braccetti a filo solo con maniglia, maggiorazione a pag. 118 Wire hinges can only be inserted in fronts with handles. Surcharge on page 118										
<b>Base con 1 ribalta</b> Base with 1 flap-door 		VOLm <sup>3</sup>	Kg							
		0,127	16,5	P.   D. 480	SL1BR1432	<b>293</b>	<b>337</b>	<b>377</b>	<b>389</b>	<b>335</b>
		0,151	19,5	P.   D. 576	SL1BR1532	<b>309</b>	<b>355</b>	<b>397</b>	<b>409</b>	<b>354</b>
				Maniglia Slim   Slim handle		16	16	16	16	16
				Maniglia gola   Groove handle		39	39	39	39	39
<b>Base con 1 ribalta</b> Base with 1 flap-door 		VOLm <sup>3</sup>	Kg							
		0,187	22,5	P.   D. 480	SL1BR1452	<b>356</b>	<b>394</b>	<b>449</b>	<b>465</b>	<b>400</b>
		0,222	25	P.   D. 576	SL1BR1552	<b>376</b>	<b>413</b>	<b>465</b>	<b>482</b>	<b>424</b>
				Maniglia Slim   Slim handle		19	19	19	19	19
				Maniglia gola   Groove handle		46	46	46	46	46
<b>Base con 1 ribalta</b> Base with 1 flap-door 		VOLm <sup>3</sup>	Kg							
		0,247	31	P.   D. 480	SL1BR1462	<b>434</b>	<b>464</b>	<b>525</b>	<b>543</b>	<b>493</b>
		0,293	35,5	P.   D. 576	SL1BR1562	<b>452</b>	<b>487</b>	<b>547</b>	<b>567</b>	<b>513</b>
				Maniglia Slim   Slim handle		30	30	30	30	30
				Maniglia gola   Groove handle		51	51	51	51	51
<b>Base con 2 ribalte</b> Base with 2 flap-doors 		VOLm <sup>3</sup>	Kg							
		0,247	31	P.   D. 480	SLBR2462	<b>499</b>	<b>539</b>	<b>601</b>	<b>618</b>	<b>565</b>
		0,293	35,5	P.   D. 576	SLBR2562	<b>517</b>	<b>562</b>	<b>623</b>	<b>642</b>	<b>585</b>
				Maniglia Slim   Slim handle		32	32	32	32	32
				Maniglia gola   Groove handle		78	78	78	78	78
<b>Base con 2 ribalte</b> Base with 2 flap-doors 		VOLm <sup>3</sup>	Kg							
		0,307	36,5	P.   D. 480	SL1BR2472	<b>577</b>	<b>621</b>	<b>693</b>	<b>714</b>	<b>650</b>
		0,364	41,5	P.   D. 576	SL1BR2572	<b>610</b>	<b>656</b>	<b>727</b>	<b>749</b>	<b>685</b>
				Maniglia Slim   Slim handle		36	36	36	36	36
				Maniglia gola   Groove handle		86	86	86	86	86
<b>Base con 2 ribalte</b> Base with 2 flap-doors 		VOLm <sup>3</sup>	Kg							
		0,367	42	P.   D. 480	SL1BR2482	<b>630</b>	<b>666</b>	<b>750</b>	<b>775</b>	<b>707</b>
		0,435	48	P.   D. 576	SL1BR2582	<b>664</b>	<b>702</b>	<b>787</b>	<b>813</b>	<b>743</b>
				Maniglia Slim   Slim handle		38	38	38	38	38
				Maniglia gola   Groove handle		92	92	92	92	92
<b>Base con 3 ribalte</b> Base with 3 flap-doors 		VOLm <sup>3</sup>	Kg							
		0,367	45	P.   D. 480	SL1BR3482	<b>730</b>	<b>774</b>	<b>857</b>	<b>880</b>	<b>818</b>
		0,435	52	P.   D. 576	SL1BR3582	<b>767</b>	<b>812</b>	<b>892</b>	<b>917</b>	<b>856</b>
				Maniglia Slim   Slim handle		48	48	48	48	48
				Maniglia gola   Groove handle		117	117	117	117	117

Ulteriori combinazioni di aperture e finiture sono possibili utilizzando le scocche vuote a pag. | Additional finishes and opening combinations are possible using the empty bodies on page 59

# BASI A TERRA O IN APPOGGIO | FREE-STANDING OR SUPPORTED BASES H.320





N.B: L'interno del mobile e del vano a giorno è in materico abbinato per il rovere termotrattato e nodi, in laccato opaco in tinta per i laccati, le superfici UP e per le essenze rovere gesso, visone, cenere e castoro

		codice code	lacc. opaco matt lacq.	essenza cat. 1 wood cat. 1	essenza cat. 2 wood cat. 2	rovere lacc. matt lacq. oak	lacc. lucido glossy lacq.	superfici UP UP surface	
- Aggiungere sempre il top alle basi a pag.   Always add the top to the bases on page 72 - Apertura standard "push and pull"   Standard 'push and pull' opening - Specificare nell'ordine se a terra o in appoggio   In the order, specify whether positioned free-standing or supported - Possibile l'inserimento di braccetti a filo solo con maniglia, maggiorazione a pag. 118 Wire hinges can only be inserted in fronts with handles. Surcharge on page 118									
<b>Base con 1 cestone e 1 ribalta</b> Base with 1 deep drawer and 1 flap-door									
	VOLm <sup>3</sup>	Kg	P.   D. 480						
	0,247	36	SX   LH	SL1BMS462	498	534	595	613	562
			DX   RH	SL1BMD462	498	534	595	613	562
	VOLm <sup>3</sup>	Kg	P.   D. 576						
	0,293	42	SX   LH	SL1BMS562	518	561	624	643	586
			DX   RH	SL1BMD562	518	561	624	643	586
		Maniglia Slim   Slim handle		23	23	23	23	23	
		Maniglia gola   Groove handle		74	74	74	74	74	
<b>Base con 1 cestone e 1 ribalta</b> Base with 1 deep drawer and 1 flap-door									
	VOLm <sup>3</sup>	Kg	P.   D. 480						
	0,307	42,5	SX   LH	SL1BMS472	584	624	696	718	656
			DX   RH	SL1BMD472	584	624	696	718	656
	VOLm <sup>3</sup>	Kg	P.   D. 576						
	0,364	48,5	SX   LH	SL1BMS572	621	665	737	759	695
			DX   RH	SL1BMD572	621	665	737	759	695
		Maniglia Slim   Slim handle		25	25	25	25	25	
		Maniglia gola   Groove handle		80	80	80	80	80	
<b>Base con 1 cestone e 1 ribalta</b> Base with 1 deep drawer and 1 flap-door									
	VOLm <sup>3</sup>	Kg	P.   D. 480						
	0,367	49	SX   LH	SL1BMS482	639	673	755	780	717
			DX   RH	SL1BMD482	639	673	755	780	717
	VOLm <sup>3</sup>	Kg	P.   D. 576						
	0,435	56	SX   LH	SL1BMS582	677	717	800	826	757
			DX   RH	SL1BMD582	677	717	800	826	757
		Maniglia Slim   Slim handle		27	27	27	27	27	
		Maniglia gola   Groove handle		85	85	85	85	85	

Ulteriori combinazioni di aperture e finiture sono possibili utilizzando le scocche vuote a pag. | Additional finishes and opening combinations are possible using the empty bodies on page 59

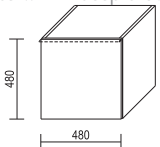
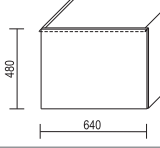
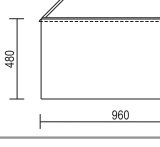
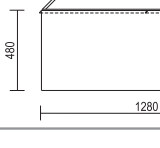
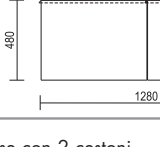
# BASI A TERRA O IN APPOGGIO | FREE-STANDING OR SUPPORTED BASES H.480

N.B: The interior of the cabinet and open compartment has matching textured f. for heat-treated oak and oak knots finishes and matching matte lacquer for lacquers, UP surfaces, in addition to oak gesso, oak visone, oak cenere and oak castoro woods.

			codice code	lacc. opaco matt lacq.	essenza cat. 1 wood cat. 1	essenza cat. 2 wood cat. 2	rovere lacc. matt lacq. oak	lacc. lucido glossy lacq.	superfici UP UP surface	
- Aggiungere sempre il top alle basi a pag.   Always add the top to the bases on page 72 - Apertura standard "push and pull"   Standard 'push and pull' opening - Specificare nell'ordine se a terra o in appoggio   In the order, specify whether positioned free-standing or supported										
<b>Base con 1 cestone</b> Base with 1 deep drawer 			VOL.m <sup>3</sup> Kg							
			0,147 22	P.   D. 480	SL1BC1423	<b>299</b>	<b>335</b>	<b>381</b>	<b>396</b>	<b>365</b>
			0,173 24	P.   D. 576	SL1BC1523	<b>321</b>	<b>361</b>	<b>408</b>	<b>424</b>	<b>394</b>
				Maniglia Slim   Slim handle		6	6	6	6	6
				Maniglia gola   Groove handle		32	32	32	32	32
<b>Base con 1 cestone</b> Base with 1 deep drawer 			VOL.m <sup>3</sup> Kg							
			0,190 26	P.   D. 480	SL1BC1433	<b>336</b>	<b>371</b>	<b>424</b>	<b>440</b>	<b>402</b>
			0,224 29	P.   D. 576	SL1BC1533	<b>357</b>	<b>401</b>	<b>457</b>	<b>475</b>	<b>437</b>
				Maniglia Slim   Slim handle		7	7	7	7	7
				Maniglia gola   Groove handle		35	35	35	35	35
<b>Base con 1 cestone</b> Base with 1 deep drawer 			VOL.m <sup>3</sup> Kg							
			0,277 34	P.   D. 480	SL1BC1453	<b>417</b>	<b>463</b>	<b>529</b>	<b>551</b>	<b>495</b>
			0,327 39	P.   D. 576	SL1BC1553	<b>445</b>	<b>501</b>	<b>569</b>	<b>592</b>	<b>536</b>
				Maniglia Slim   Slim handle		8	8	8	8	8
				Maniglia gola   Groove handle		39	39	39	39	39
<b>Base con 2 cestoni - frontale unico</b> Base with 2 deep drawers - single front 			VOL.m <sup>3</sup> Kg							
			0,363 49	P.   D. 480	SL1BC1463	<b>562</b>	<b>606</b>	<b>692</b>	<b>718</b>	<b>656</b>
			0,429 56	P.   D. 576	SL1BC1563	<b>597</b>	<b>653</b>	<b>744</b>	<b>772</b>	<b>705</b>
				Maniglia Slim   Slim handle		12	12	12	12	12
				Maniglia gola   Groove handle		43	43	43	43	43
<b>Base con 2 cestoni</b> Base with 2 deep drawers 			VOL.m <sup>3</sup> Kg							
			0,363 49	P.   D. 480	SL1BC2463	<b>570</b>	<b>613</b>	<b>707</b>	<b>732</b>	<b>666</b>
			0,429 56	P.   D. 576	SL1BC2563	<b>602</b>	<b>663</b>	<b>759</b>	<b>788</b>	<b>716</b>
				Maniglia Slim   Slim handle		14	14	14	14	14
				Maniglia gola   Groove handle		70	70	70	70	70
<b>Base con 2 cestoni</b> Base with 2 deep drawers 			VOL.m <sup>3</sup> Kg							
			0,450 58	P.   D. 480	SL1BC2473	<b>678</b>	<b>731</b>	<b>832</b>	<b>864</b>	<b>775</b>
			0,532 65	P.   D. 576	SL1BC2573	<b>724</b>	<b>782</b>	<b>885</b>	<b>918</b>	<b>821</b>
				Maniglia Slim   Slim handle		14	14	14	14	14
				Maniglia gola   Groove handle		74	74	74	74	74
<b>Base con 2 cestoni</b> Base with 2 deep drawers 			VOL.m <sup>3</sup> Kg							
			0,536 66	P.   D. 480	SL1BC2483	<b>753</b>	<b>804</b>	<b>915</b>	<b>950</b>	<b>860</b>
			0,634 74	P.   D. 576	SL1BC2583	<b>800</b>	<b>854</b>	<b>970</b>	<b>1.009</b>	<b>911</b>
				Maniglia Slim   Slim handle		16	16	16	16	16
				Maniglia gola   Groove handle		78	78	78	78	78
<b>Base con 3 cestoni</b> Base with 3 deep drawers 			VOL.m <sup>3</sup> Kg							
			0,536 72	P.   D. 480	SL1BC3483	<b>838</b>	<b>882</b>	<b>1.007</b>	<b>1.041</b>	<b>951</b>
			0,628 82	P.   D. 576	SL1BC3583	<b>886</b>	<b>940</b>	<b>1.068</b>	<b>1.106</b>	<b>1.010</b>
				Maniglia Slim   Slim handle		21	21	21	21	21
				Maniglia gola   Groove handle		105	105	105	105	105

Ulteriori combinazioni di aperture e finiture sono possibili utilizzando le scocche vuote a pag. | Additional finishes and opening combinations are possible using the empty bodies on page 59



# BASI A TERRA O IN APPOGGIO | FREE-STANDING OR SUPPORTED BASES H.480

N.B: L'interno del mobile e del vano a giorno è in materico abbinato per il rovere termotrattato e nodi, in laccato opaco in tinta per i laccati, le superfici UP e per le essenze rovere gesso, visone, cenere e castoro

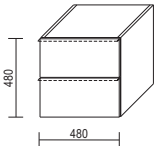
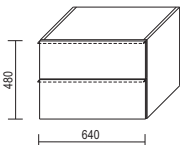
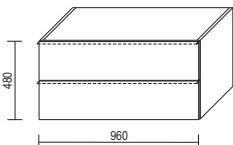
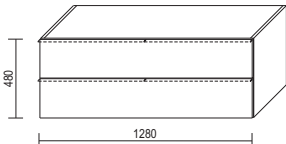
- Aggiungere sempre il top alle basi a pag.   Always add the top to the bases on page 72 - Apertura standard "push and pull"   Standard 'push and pull' opening - Specificare nell'ordine se a terra o in appoggio   In the order, specify whether positioned free-standing or supported - Non è possibile l'abbinamento di cassetti con maniglia insieme a cassetti apertura "push and pull"   Drawers with handles cannot be combined with "push and pull"-opening drawers		codice code	lacc. opaco matt lacq.	essenza cat. 1 wood cat. 1	essenza cat. 2 wood cat. 2	rovere lacc. matt lacq. oak	lacc. lucido glossy lacq.	superfici UP UP surface
Base con 2 cassetti Base with 2 drawers  	VOLm <sup>3</sup> Kg							
	0,147 24	P.   D. 480	SL1BT2423	<b>363</b>	<b>414</b>	<b>465</b>	<b>480</b>	<b>427</b>
	0,173 27	P.   D. 576	SL1BT2523	<b>389</b>	<b>440</b>	<b>492</b>	<b>511</b>	<b>460</b>
		Maniglia Slim   Slim handle Maniglia gola   Groove handle		12 64	12 64	12 64	12 64	12 64
Base con 2 cassetti Base with 2 drawers  	VOLm <sup>3</sup> Kg							
	0,190 28	P.   D. 480	SL1BT2433	<b>412</b>	<b>464</b>	<b>521</b>	<b>538</b>	<b>478</b>
	0,224 32	P.   D. 576	SL1BT2533	<b>435</b>	<b>495</b>	<b>557</b>	<b>575</b>	<b>514</b>
		Maniglia Slim   Slim handle Maniglia gola   Groove handle		14 70	14 70	14 70	14 70	14 70
Base con 2 cassetti Base with 2 drawers  	VOLm <sup>3</sup> Kg							
	0,277 35	P.   D. 480	SL1BT2453	<b>507</b>	<b>572</b>	<b>649</b>	<b>671</b>	<b>588</b>
	0,327 40	P.   D. 576	SL1BT2553	<b>539</b>	<b>611</b>	<b>688</b>	<b>710</b>	<b>630</b>
		Maniglia Slim   Slim handle Maniglia gola   Groove handle		16 78	16 78	16 78	16 78	16 78
Base con 4 cassetti - frontale unico Base with 4 drawers - single front  	VOLm <sup>3</sup> Kg							
	0,362 52	P.   D. 480	SL1BT2463	<b>720</b>	<b>791</b>	<b>893</b>	<b>920</b>	<b>814</b>
	0,429 60	P.   D. 576	SL1BT2563	<b>756</b>	<b>837</b>	<b>945</b>	<b>976</b>	<b>864</b>
		Maniglia Slim   Slim handle Maniglia gola   Groove handle		24 86	24 86	24 86	24 86	24 86

Ulteriori combinazioni di aperture e finiture sono possibili utilizzando le scocche vuote a pag. | Additional finishes and opening combinations are possible using the empty bodies on page 59

# BASI A TERRA O IN APPOGGIO | FREE-STANDING OR SUPPORTED BASES H.480

N.B: The interior of the cabinet and open compartment has matching textured f. for heat-treated oak and oak knots finishes and matching matte lacquer for lacquers, UP surfaces, in addition to oak gesso, oak visone, oak cenere and oak castoro woods.

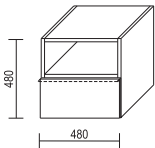
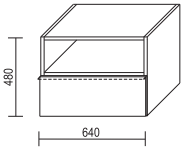
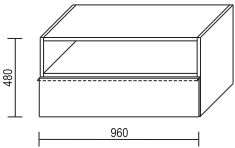
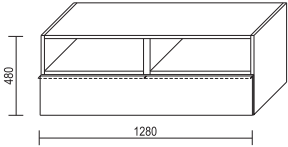
- Aggiungere sempre il top alle basi a pag.   Always add the top to the bases on page 72 - Apertura standard "push and pull"   Standard 'push and pull' opening - Specificare nell'ordine se a terra o in appoggio   In the order, specify whether positioned free-standing or supported		codice code	lacc. opaco matt lacq.	essenza cat. 1 wood cat. 1	essenza cat. 2 wood cat. 2	rovere lacc. matt lacq. oak	lacc. lucido glossy lacq.	superfici UP UP surface		
Base con 1 cassetto e 1 vano a giorno Base with 1 drawer and 1 open compartment  		VOL.m <sup>3</sup> Kg								
		0,147 19,1	P.   D. 480	SL1BT1423	<b>331</b>	<b>349</b>	<b>399</b>	<b>410</b>	<b>383</b>	
		0,173 21,6		P.   D. 576	SL1BT1523	<b>361</b>	<b>376</b>	<b>430</b>	<b>444</b>	<b>420</b>
				Maniglia Slim   Slim handle		<b>6</b>	<b>6</b>	<b>6</b>	<b>6</b>	<b>6</b>
				Maniglia gola   Groove handle		<b>32</b>	<b>32</b>	<b>32</b>	<b>32</b>	<b>32</b>
Base con 1 cassetto e 1 vano a giorno Base with 1 drawer and 1 open compartment  		VOL.m <sup>3</sup> Kg								
		0,190 22	P.   D. 480	SL1BT1433	<b>374</b>	<b>383</b>	<b>443</b>	<b>455</b>	<b>426</b>	
		0,224 25,4		P.   D. 576	SL1BT1533	<b>401</b>	<b>414</b>	<b>480</b>	<b>493</b>	<b>465</b>
				Maniglia Slim   Slim handle		<b>7</b>	<b>7</b>	<b>7</b>	<b>7</b>	<b>7</b>
				Maniglia gola   Groove handle		<b>35</b>	<b>35</b>	<b>35</b>	<b>35</b>	<b>35</b>
Base con 1 cassetto e 1 vano a giorno Base with 1 drawer and 1 open compartment  		VOL.m <sup>3</sup> Kg								
		0,277 26,9	P.   D. 480	SL1BT1453	<b>466</b>	<b>475</b>	<b>551</b>	<b>566</b>	<b>526</b>	
		0,327 31,2		P.   D. 576	SL1BT1553	<b>503</b>	<b>515</b>	<b>595</b>	<b>610</b>	<b>574</b>
				Maniglia Slim   Slim handle		<b>8</b>	<b>8</b>	<b>8</b>	<b>8</b>	<b>8</b>
				Maniglia gola   Groove handle		<b>39</b>	<b>39</b>	<b>39</b>	<b>39</b>	<b>39</b>
Base con 2 cassetti (frontale unico) e 2 vani a giorno Base with 2 drawers (single front) and 2 open compartments  		VOL.m <sup>3</sup> Kg								
		0,362 41,1	P.   D. 480	SL1BT1463	<b>645</b>	<b>633</b>	<b>741</b>	<b>758</b>	<b>712</b>	
		0,429 47,9		P.   D. 576	SL1BT1563	<b>689</b>	<b>682</b>	<b>798</b>	<b>818</b>	<b>769</b>
				Maniglia Slim   Slim handle		<b>12</b>	<b>12</b>	<b>12</b>	<b>12</b>	<b>12</b>
				Maniglia gola   Groove handle		<b>43</b>	<b>43</b>	<b>43</b>	<b>43</b>	<b>43</b>

Ulteriori combinazioni di aperture e finiture sono possibili utilizzando le scocche vuote a pag. | Additional finishes and opening combinations are possible using the empty bodies on page 59

N.B: L'interno del mobile e del vano a giorno è in materico abbinato per il rovere termotrattato e nodi, in laccato opaco in tinta per i laccati, le superfici UP e per le essenze rovere gesso, visone, cenere e castoro

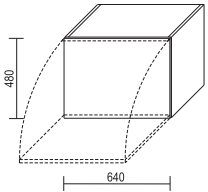
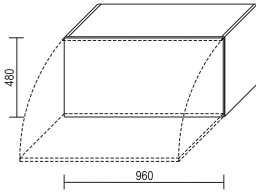
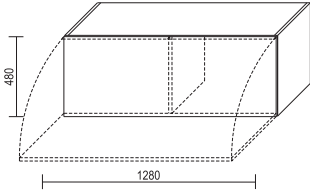
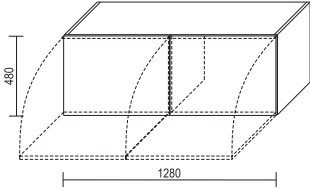
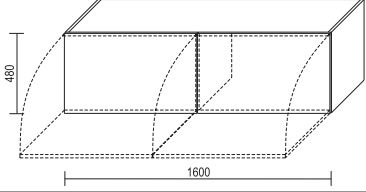
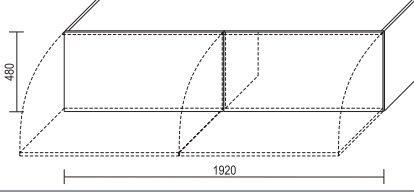
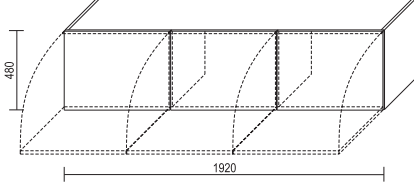
		codice code	lacc. opaco matt lacq.	essenza cat. 1 wood cat. 1	essenza cat. 2 wood cat. 2	rovere lacc. matt lacq. oak	lacc. lucido glossy lacq.	superfici UP UP surface
- Aggiungere sempre il top alle basi a pag.   Always add the top to the bases on page 72 - Apertura standard "push and pull"   Standard 'push and pull' opening - Specificare nell'ordine se a terra o in appoggio   In the order, specify whether positioned free-standing or supported - Possibile l'inserimento di braccetti a filo solo con maniglia, maggiorazione a pag. 118 Wire hinges can only be inserted in fronts with handles. Surcharge on page 118								
Base con 1 ribalta   Base with 1 flap-door 								
VOLm <sup>3</sup>	Kg							
0,190	21	P.   D. 480	SL1BR1433	<b>347</b>	<b>393</b>	<b>442</b>	<b>459</b>	<b>415</b>
0,224	24	P.   D. 576	SL1BR1533	<b>366</b>	<b>416</b>	<b>468</b>	<b>486</b>	<b>445</b>
		Maniglia Slim   Slim handle		16	16	16	16	16
		Maniglia gola   Groove handle		39	39	39	39	39
Base con 1 ribalta   Base with 1 flap-door 								
VOLm <sup>3</sup>	Kg							
0,277	28	P.   D. 480	SL1BR1453	<b>418</b>	<b>468</b>	<b>536</b>	<b>558</b>	<b>495</b>
0,327	32	P.   D. 576	SL1BR1553	<b>442</b>	<b>499</b>	<b>567</b>	<b>589</b>	<b>531</b>
		Maniglia Slim   Slim handle		19	19	19	19	19
		Maniglia gola   Groove handle		46	46	46	46	46
Base con 1 ribalta   Base with 1 flap-door 								
VOLm <sup>3</sup>	Kg							
0,363	39	P.   D. 480	SL1BR1463	<b>521</b>	<b>598</b>	<b>683</b>	<b>709</b>	<b>615</b>
0,429	45	P.   D. 576	SL1BR1563	<b>549</b>	<b>634</b>	<b>721</b>	<b>749</b>	<b>655</b>
		Maniglia Slim   Slim handle		30	30	30	30	30
		Maniglia gola   Groove handle		51	51	51	51	51
Base con 2 ribalte   Base with 2 flap-doors 								
VOLm <sup>3</sup>	Kg							
0,363	40	P.   D. 480	SL1BR2463	<b>592</b>	<b>657</b>	<b>743</b>	<b>770</b>	<b>692</b>
0,429	45	P.   D. 576	SL1BR2563	<b>620</b>	<b>693</b>	<b>781</b>	<b>810</b>	<b>732</b>
		Maniglia Slim   Slim handle		32	32	32	32	32
		Maniglia gola   Groove handle		78	78	78	78	78
Base con 2 ribalte   Base with 2 flap-doors 								
VOLm <sup>3</sup>	Kg							
0,450	47	P.   D. 480	SL1BR2473	<b>690</b>	<b>755</b>	<b>856</b>	<b>888</b>	<b>789</b>
0,532	53	P.   D. 576	SL1BR2573	<b>728</b>	<b>792</b>	<b>895</b>	<b>928</b>	<b>829</b>
		Maniglia Slim   Slim handle		36	36	36	36	36
		Maniglia gola   Groove handle		86	86	86	86	86
Base con 2 ribalte   Base with 2 flap-doors 								
VOLm <sup>3</sup>	Kg							
0,536	53	P.   D. 480	SL1BR2483	<b>755</b>	<b>814</b>	<b>929</b>	<b>964</b>	<b>860</b>
0,634	60	P.   D. 576	SL1BR2583	<b>794</b>	<b>850</b>	<b>966</b>	<b>1.003</b>	<b>901</b>
		Maniglia Slim   Slim handle		38	38	38	38	38
		Maniglia gola   Groove handle		92	92	92	92	92
Base con 3 ribalte   Base with 3 flap-doors 								
VOLm <sup>3</sup>	Kg							
0,536	58	P.   D. 480	SL1BR3483	<b>871</b>	<b>948</b>	<b>1.061</b>	<b>1.098</b>	<b>990</b>
0,634	66	P.   D. 576	SL1BR3583	<b>913</b>	<b>985</b>	<b>1.101</b>	<b>1.139</b>	<b>1.034</b>
		Maniglia Slim   Slim handle		48	48	48	48	48
		Maniglia gola   Groove handle		117	117	117	117	117

Ulteriori combinazioni di aperture e finiture sono possibili utilizzando le scocche vuote a pag. | Additional finishes and opening combinations are possible using the empty bodies on page 59

# BASI A TERRA O IN APPOGGIO | FREE-STANDING OR SUPPORTED BASES H.480

N.B: The interior of the cabinet and open compartment has matching textured f. for heat-treated oak and oak knots finishes and matching matte lacquer for lacquers, UP surfaces, in addition to oak gesso, oak visone, oak cenere and oak castoro woods.

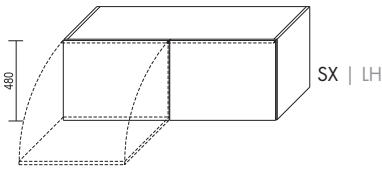
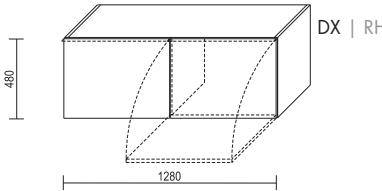
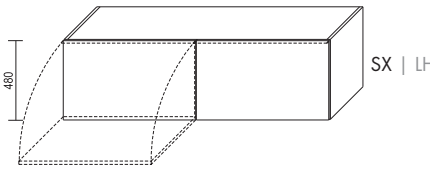
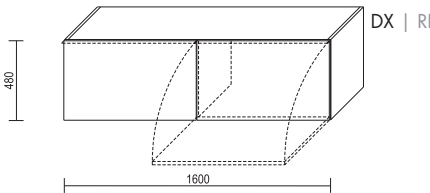
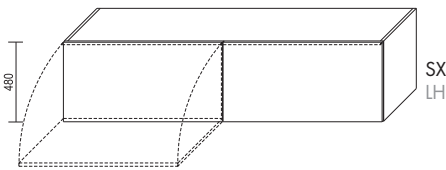
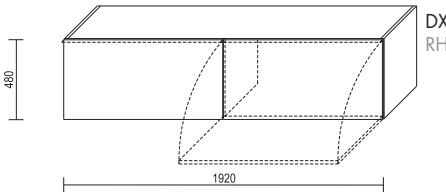
		codice code	lacc. opaco matt lacq.	essenza cat. 1 wood cat. 1	essenza cat. 2 wood cat. 2	rovere lacc. matt lacq. oak	lacc. lucido glossy lacq.
- Aggiungere sempre il top alle basi a pag.   Always add the top to the bases on page 72 - Apertura standard "push and pull"   Standard 'push and pull' opening - Specificare nell'ordine se a terra o in appoggio   In the order, specify whether positioned free-standing or supported - Possibile l'inserimento di braccetti a filo solo con maniglia, maggiorazione a pag. 118 Wire hinges can only be inserted in fronts with handles. Surcharge on page 118							superfici UP UP surface
<b>Base con 1 cestone e 1 ribalta</b> Base with 1 deep drawer and 1 flap-door							
	VOLm³ Kg 0,363 44	P.   D. 480					
		SX   LH	SL1BMS463	<b>581</b>	<b>635</b>	<b>725</b>	<b>751</b>
	VOLm³ Kg 0,429 49	P.   D. 576					
		SX   LH	SL1BMS563	<b>611</b>	<b>678</b>	<b>770</b>	<b>799</b>
		DX   RH	SL1BMD563	<b>611</b>	<b>678</b>	<b>770</b>	<b>724</b>
		Maniglia Slim   Slim handle	23	23	23	23	23
		Maniglia gola   Groove handle	74	74	74	74	74
<b>Base con 1 cestone e 1 ribalta</b> Base with 1 deep drawer and 1 flap-door							
	VOLm³ Kg 0,450 52	P.   D. 480					
		SX   LH	SL1BMS473	<b>684</b>	<b>743</b>	<b>844</b>	<b>876</b>
	VOLm³ Kg 0,532 59	P.   D. 576					
		SX   LH	SL1BMS573	<b>726</b>	<b>787</b>	<b>890</b>	<b>923</b>
		DX   RH	SL1BMD573	<b>726</b>	<b>787</b>	<b>890</b>	<b>825</b>
		Maniglia Slim   Slim handle	25	25	25	25	25
		Maniglia gola   Groove handle	80	80	80	80	80
<b>Base con 1 cestone e 1 ribalta</b> Base with 1 deep drawer and 1 flap-door							
	VOLm³ Kg 0,536 60	P.   D. 480					
		SX   LH	SL1BMS483	<b>754</b>	<b>809</b>	<b>922</b>	<b>957</b>
	VOLm³ Kg 0,634 67	P.   D. 576					
		SX   LH	SL1BMS583	<b>797</b>	<b>852</b>	<b>968</b>	<b>1.006</b>
		DX   RH	SL1BMD583	<b>797</b>	<b>852</b>	<b>968</b>	<b>906</b>
		Maniglia Slim   Slim handle	27	27	27	27	27
		Maniglia gola   Groove handle	85	85	85	85	85

Ulteriori combinazioni di aperture e finiture sono possibili utilizzando le scocche vuote a pag. | Additional finishes and opening combinations are possible using the empty bodies on page 59

N.B: L'interno del mobile e del vano a giorno è in materico abbinato per il rovere termotrattato e nodi, in laccato opaco in tinta per i laccati, le superfici UP e per le essenze rovere gesso, visone, cenere e castoro

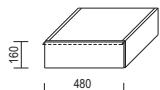
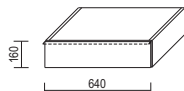
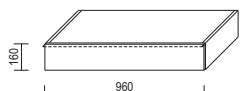
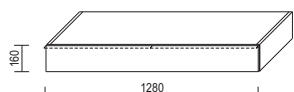
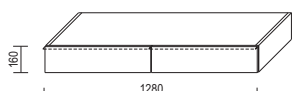
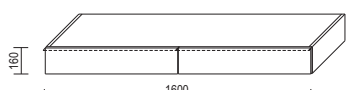
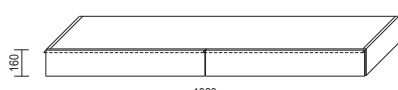
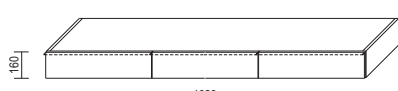
- Aggiungere sempre il top alle basi a pag.   Always add the top to the bases on page 72 - Apertura standard "push and pull"   Standard 'push and pull' opening		codice code		lacc. opaco		essenza cat. 1		essenza cat. 2		rovere lacc.		lacc. lucido	
				matt lacq.		wood cat. 1		wood cat. 2		matt lacq. oak		glossy lacq.	
												superfici UP UP surface	
Base con 1 cassetto Base with 1 drawer													
	VOLm <sup>3</sup>	Kg	P.   D. 480	SL1SC1420	<b>232</b>	<b>257</b>	<b>280</b>	<b>289</b>	<b>251</b>				
	0,054	14	P.   D. 576	SL1SC1520	<b>246</b>	<b>275</b>	<b>301</b>	<b>311</b>	<b>269</b>				
			Maniglia Slim   Slim handle		6	6	6	6	6				
			Maniglia gola   Groove handle		32	32	32	32	32				
Base con 1 cassetto Base with 1 drawer													
	VOLm <sup>3</sup>	Kg	P.   D. 480	SL1SC1430	<b>261</b>	<b>291</b>	<b>318</b>	<b>329</b>	<b>286</b>				
	0,071	17	P.   D. 576	SL1SC1530	<b>281</b>	<b>310</b>	<b>339</b>	<b>350</b>	<b>305</b>				
			Maniglia Slim   Slim handle		7	7	7	7	7				
			Maniglia gola   Groove handle		35	35	35	35	35				
Base con 1 cassetto Base with 1 drawer													
	VOLm <sup>3</sup>	Kg	P.   D. 480	SL1SC1450	<b>336</b>	<b>365</b>	<b>396</b>	<b>408</b>	<b>367</b>				
	0,104	23	P.   D. 576	SL1SC1550	<b>356</b>	<b>386</b>	<b>419</b>	<b>431</b>	<b>391</b>				
			Maniglia Slim   Slim handle		8	8	8	8	8				
			Maniglia gola   Groove handle		39	39	39	39	39				
Base con 2 cassetti - frontale unico Base with 2 drawers - single front													
	VOLm <sup>3</sup>	Kg	P.   D. 480	SL1SC1460	<b>456</b>	<b>487</b>	<b>528</b>	<b>545</b>	<b>489</b>				
	0,137	32	P.   D. 576	SL1SC1560	<b>488</b>	<b>509</b>	<b>553</b>	<b>571</b>	<b>520</b>				
			Maniglia Slim   Slim handle		12	12	12	12	12				
			Maniglia gola   Groove handle		43	43	43	43	43				
Base con 2 cassetti Base with 2 drawers													
	VOLm <sup>3</sup>	Kg	P.   D. 480	SL1SC2460	<b>451</b>	<b>487</b>	<b>529</b>	<b>547</b>	<b>488</b>				
	0,137	32	P.   D. 576	SL1SC2560	<b>485</b>	<b>510</b>	<b>556</b>	<b>573</b>	<b>517</b>				
			Maniglia Slim   Slim handle		14	14	14	14	14				
			Maniglia gola   Groove handle		70	70	70	70	70				
Base con 2 cassetti Base with 2 drawers													
	VOLm <sup>3</sup>	Kg	P.   D. 480	SL1SC2470	<b>557</b>	<b>588</b>	<b>638</b>	<b>658</b>	<b>592</b>				
	0,171	39	P.   D. 576	SL1SC2570	<b>597</b>	<b>625</b>	<b>678</b>	<b>701</b>	<b>633</b>				
			Maniglia Slim   Slim handle		14	14	14	14	14				
			Maniglia gola   Groove handle		74	74	74	74	74				
Base con 2 cassetti Base with 2 drawers													
	VOLm <sup>3</sup>	Kg	P.   D. 480	SL1SC2480	<b>607</b>	<b>641</b>	<b>693</b>	<b>714</b>	<b>654</b>				
	0,204	45	P.   D. 576	SL1SC2580	<b>650</b>	<b>677</b>	<b>736</b>	<b>756</b>	<b>699</b>				
			Maniglia Slim   Slim handle		16	16	16	16	16				
			Maniglia gola   Groove handle		78	78	78	78	78				
Base con 3 cassetti Base with 3 drawers													
	VOLm <sup>3</sup>	Kg	P.   D. 480	SL1SC3480	<b>674</b>	<b>715</b>	<b>774</b>	<b>799</b>	<b>722</b>				
	0,204	46	P.   D. 576	SL1SC3580	<b>721</b>	<b>754</b>	<b>820</b>	<b>843</b>	<b>769</b>				
			Maniglia Slim   Slim handle		21	21	21	21	21				
			Maniglia gola   Groove handle		105	105	105	105	105				

Ulteriori combinazioni di aperture e finiture sono possibili utilizzando le scocche vuote a pag. | Additional finishes and opening combinations are possible using the empty bodies on page 59

N.B: The interior of the cabinet and open compartment has matching textured f. for heat-treated oak and oak knots finishes and matching matte lacquer for lacquers, UP surfaces, in addition to oak gesso, oak visone, oak cenere and oak castoro woods.

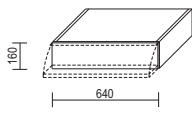
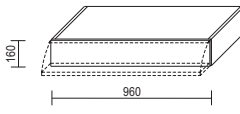
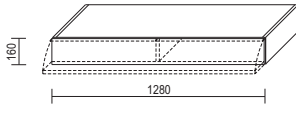
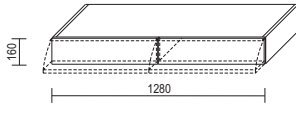
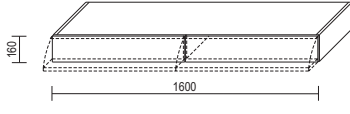
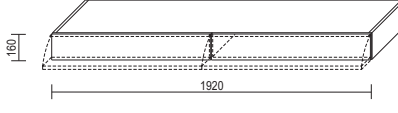
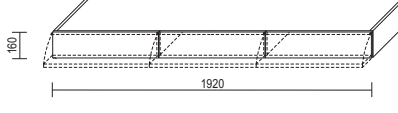
- Aggiungere sempre il top alle basi a pag.   Always add the top to the bases on page 72 - Apertura standard "push and pull"   Standard 'push and pull' opening		codice code	lacc. opaco matt lacq.	essenza cat. 1 wood cat. 1	essenza cat. 2 wood cat. 2	rovere lacc. matt lacq. oak	lacc. lucido glossy lacq.		
Base con 1 ribalta Base with 1 flap-door									
	VOLm <sup>3</sup> Kg								
	0,071 12 0,084 15	P.   D. 480 P.   D. 576	SL1SR1430 SL1SR1530	<b>247</b> <b>264</b>	<b>279</b> <b>295</b>	<b>302</b> <b>319</b>	<b>310</b> <b>328</b>	<b>274</b> <b>291</b>	
		Maniglia Slim   Slim handle Maniglia gola   Groove handle		16 39	16 39	16 39	16 39	16 39	
Base con 1 ribalta Base with 1 flap-door									
	VOLm <sup>3</sup> Kg								
	0,104 17 0,123 20	P.   D. 480 P.   D. 576	SL1SR1450 SL1SR1550	<b>313</b> <b>330</b>	<b>344</b> <b>362</b>	<b>372</b> <b>390</b>	<b>380</b> <b>399</b>	<b>342</b> <b>363</b>	
		Maniglia Slim   Slim handle Maniglia gola   Groove handle		19 46	19 46	19 46	19 46	19 46	
Base con 1 ribalta Base with 1 flap-door									
	VOLm <sup>3</sup> Kg								
	0,137 23 0,163 27	P.   D. 480 P.   D. 576	SL1SR1460 SL1SR1560	<b>378</b> <b>406</b>	<b>412</b> <b>429</b>	<b>439</b> <b>458</b>	<b>452</b> <b>472</b>	<b>414</b> <b>439</b>	
		Maniglia Slim   Slim handle Maniglia gola   Groove handle		30 51	30 51	30 51	30 51	30 51	
Base con 2 ribalte Base with 2 flap-doors									
	VOLm <sup>3</sup> Kg								
	0,137 23 0,163 27	P.   D. 480 P.   D. 576	SL1SR2460 SL1SR2560	<b>423</b> <b>451</b>	<b>463</b> <b>480</b>	<b>497</b> <b>516</b>	<b>509</b> <b>529</b>	<b>464</b> <b>489</b>	
		Maniglia Slim   Slim handle Maniglia gola   Groove handle		32 78	32 78	32 78	32 78	32 78	
Base con 2 ribalte Base with 2 flap-doors									
	VOLm <sup>3</sup> Kg								
	0,171 29 0,202 33	P.   D. 480 P.   D. 576	SL1SR2470 SL1SR2570	<b>511</b> <b>545</b>	<b>550</b> <b>579</b>	<b>592</b> <b>624</b>	<b>606</b> <b>639</b>	<b>552</b> <b>585</b>	
		Maniglia Slim   Slim handle Maniglia gola   Groove handle		36 86	36 86	36 86	36 86	36 86	
Base con 2 ribalte Base with 2 flap-doors									
	VOLm <sup>3</sup> Kg								
	0,204 35 0,241 37	P.   D. 480 P.   D. 576	SL1SR2480 SL1SR2580	<b>561</b> <b>598</b>	<b>599</b> <b>629</b>	<b>645</b> <b>678</b>	<b>658</b> <b>692</b>	<b>604</b> <b>643</b>	
		Maniglia Slim   Slim handle Maniglia gola   Groove handle		38 92	38 92	38 92	38 92	38 92	
Base con 3 ribalte Base with 3 flap-doors									
	VOLm <sup>3</sup> Kg								
	0,204 36 0,241 38	P.   D. 480 P.   D. 576	SL1SR3480 SL1SR3580	<b>632</b> <b>670</b>	<b>679</b> <b>709</b>	<b>726</b> <b>760</b>	<b>742</b> <b>777</b>	<b>686</b> <b>727</b>	
		Maniglia Slim   Slim handle Maniglia gola   Groove handle		48 117	48 117	48 117	48 117	48 117	

Ulteriori combinazioni di aperture e finiture sono possibili utilizzando le scocche vuote a pag. | Additional finishes and opening combinations are possible using the empty bodies on page 59

N.B: L'interno del mobile e del vano a giorno è in materico abbinato per il rovere termotrattato e nodi, in laccato opaco in tinta per i laccati, le superfici UP e per le essenze rovere gesso, visone, cenere e castoro

- Aggiungere sempre il top alle basi a pag. | Always add the top to the bases on page 72  
 - Apertura standard "push and pull" | Standard 'push and pull' opening

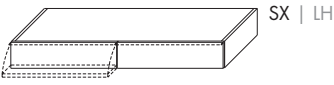
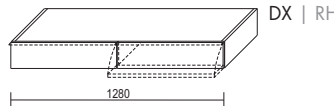
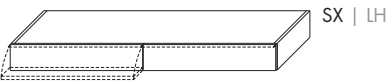
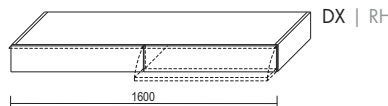
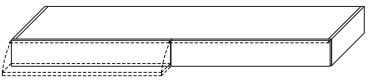
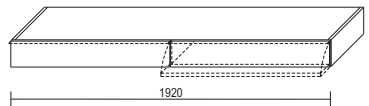
		codice code	lacc. opaco matt lacq.	essenza cat. 1 wood cat. 1	essenza cat. 2 wood cat. 2	rovere lacc. matt lacq. oak	lacc. lucido glossy lacq.	superfici UP UP surface
Base con 1 cassetto e 1 ribalta Base with 1 drawer and 1 flap-door								
	VOLm³ kg	P.   D. 480						
	0,137 27	SX   LH	SL1SMS460	<b>437</b>	<b>475</b>	<b>513</b>	<b>528</b>	<b>476</b>
	VOLm³ Kg	P.   D. 576						
	0,163 32	SX   LH	SL1SMS560	<b>468</b>	<b>495</b>	<b>536</b>	<b>551</b>	<b>503</b>
		DX   RH	SL1SMD560	<b>468</b>	<b>495</b>	<b>536</b>	<b>551</b>	<b>503</b>
		Maniglia Slim   Slim handle		23	23	23	23	23
		Maniglia gola   Groove handle		74	74	74	74	74
Base con 1 cassetto e 1 ribalta Base with 1 drawer and 1 flap-door								
	VOLm³ Kg	P.   D. 480						
	0,171 34	SX   LH	SL1SMS470	<b>534</b>	<b>569</b>	<b>615</b>	<b>632</b>	<b>572</b>
	VOLm³ Kg	P.   D. 576						
	0,202 38,5	SX   LH	SL1SMS570	<b>571</b>	<b>602</b>	<b>651</b>	<b>670</b>	<b>609</b>
		DX   RH	SL1SMD570	<b>571</b>	<b>602</b>	<b>651</b>	<b>670</b>	<b>609</b>
		Maniglia Slim   Slim handle		25	25	25	25	25
		Maniglia gola   Groove handle		80	80	80	80	80
Base con 1 cassetto e 1 ribalta Base with 1 drawer and 1 flap-door								
	VOLm³ Kg	P.   D. 480						
	0,204 40,5	SX   LH	SL1SMS480	<b>584</b>	<b>620</b>	<b>669</b>	<b>686</b>	<b>629</b>
	VOLm³ Kg	P.   D. 576						
	0,241 43,5	SX   LH	SL1SMS580	<b>624</b>	<b>653</b>	<b>707</b>	<b>724</b>	<b>671</b>
		DX   RH	SL1SMD580	<b>624</b>	<b>653</b>	<b>707</b>	<b>724</b>	<b>671</b>
		Maniglia Slim   Slim handle		27	27	27	27	27
		Maniglia gola   Groove handle		85	85	85	85	85

Ulteriori combinazioni di aperture e finiture sono possibili utilizzando le scocche vuote a pag. | Additional finishes and opening combinations are possible using the empty bodies on page 59

N.B: The interior of the cabinet and open compartment has matching textured f. for heat-treated oak and oak knots finishes and matching matte lacquer for lacquers, UP surfaces, in addition to oak gesso, oak visone, oak cenere and oak castoro woods.

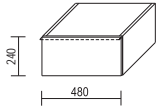
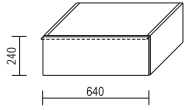
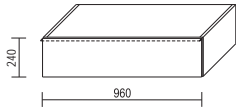
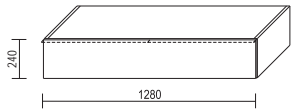
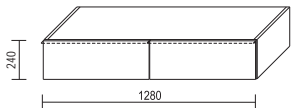
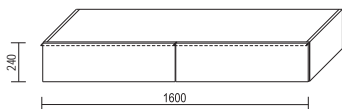
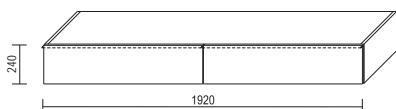
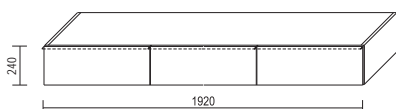
- Aggiungere sempre il top alle basi a pag.   Always add the top to the bases on page 72 - Apertura standard "push and pull"   Standard 'push and pull' opening		codice code	lacc. opaco matt lacq.	essenza cat. 1 wood cat. 1	essenza cat. 2 wood cat. 2	rovere lacc. matt lacq. oak	lacc. lucido glossy lacq.	superfici UP UP surface
<b>Base con 1 cassetto</b> Base with 1 drawer  	VOL.m <sup>3</sup> Kg							
	0,074 11	P.   D. 480	SL1SC1421	<b>247</b>	<b>289</b>	<b>321</b>	<b>329</b>	<b>276</b>
	0,087 12	P.   D. 576	SL1SC1521	<b>264</b>	<b>309</b>	<b>342</b>	<b>351</b>	<b>297</b>
		Maniglia Slim   Slim handle		6	6	6	6	6
		Maniglia gola   Groove handle		32	32	32	32	32
<b>Base con 1 cassetto</b> Base with 1 drawer  	VOL.m <sup>3</sup> Kg							
	0,095 13	P.   D. 480	SL1SC1431	<b>283</b>	<b>329</b>	<b>363</b>	<b>371</b>	<b>315</b>
	0,112 14,5	P.   D. 576	SL1SC1531	<b>303</b>	<b>350</b>	<b>385</b>	<b>396</b>	<b>337</b>
		Maniglia Slim   Slim handle		7	7	7	7	7
		Maniglia gola   Groove handle		35	35	35	35	35
<b>Base con 1 cassetto</b> Base with 1 drawer  	VOL.m <sup>3</sup> Kg							
	0,139 17	P.   D. 480	SL1SC1451	<b>359</b>	<b>410</b>	<b>451</b>	<b>462</b>	<b>397</b>
	0,164 19,5	P.   D. 576	SL1SC1551	<b>384</b>	<b>428</b>	<b>471</b>	<b>482</b>	<b>424</b>
		Maniglia Slim   Slim handle		8	8	8	8	8
		Maniglia gola   Groove handle		39	39	39	39	39
<b>Base con 2 cassetti - frontale unico</b> Base with 2 drawers - single front  	VOL.m <sup>3</sup> Kg							
	0,182 24,5	P.   D. 480	SL1SC1461	<b>484</b>	<b>534</b>	<b>586</b>	<b>599</b>	<b>530</b>
	0,215 28	P.   D. 576	SL1SC1561	<b>516</b>	<b>559</b>	<b>614</b>	<b>631</b>	<b>562</b>
		Maniglia Slim   Slim handle		12	12	12	12	12
		Maniglia gola   Groove handle		43	43	43	43	43
<b>Base con 2 cassetti</b> Base with 2 drawers  	VOL.m <sup>3</sup> Kg							
	0,182 24,5	P.   D. 480	SL1SC2461	<b>485</b>	<b>538</b>	<b>590</b>	<b>603</b>	<b>532</b>
	0,215 28	P.   D. 576	SL1SC2561	<b>517</b>	<b>566</b>	<b>621</b>	<b>637</b>	<b>565</b>
		Maniglia Slim   Slim handle		14	14	14	14	14
		Maniglia gola   Groove handle		70	70	70	70	70
<b>Base con 2 cassetti</b> Base with 2 drawers  	VOL.m <sup>3</sup> Kg							
	0,225 29	P.   D. 480	SL1SC2471	<b>592</b>	<b>648</b>	<b>712</b>	<b>730</b>	<b>647</b>
	0,266 32,5	P.   D. 576	SL1SC2571	<b>635</b>	<b>687</b>	<b>751</b>	<b>769</b>	<b>690</b>
		Maniglia Slim   Slim handle		14	14	14	14	14
		Maniglia gola   Groove handle		74	74	74	74	74
<b>Base con 2 cassetti</b> Base with 2 drawers  	VOL.m <sup>3</sup> Kg							
	0,268 33	P.   D. 480	SL1SC2481	<b>649</b>	<b>707</b>	<b>777</b>	<b>795</b>	<b>710</b>
	0,317 37	P.   D. 576	SL1SC2581	<b>695</b>	<b>747</b>	<b>817</b>	<b>837</b>	<b>756</b>
		Maniglia Slim   Slim handle		16	16	16	16	16
		Maniglia gola   Groove handle		78	78	78	78	78
<b>Base con 3 cassetti</b> Base with 3 drawers  	VOL.m <sup>3</sup> Kg							
	0,268 36	P.   D. 480	SL1SC3481	<b>722</b>	<b>784</b>	<b>855</b>	<b>874</b>	<b>785</b>
	0,317 41	P.   D. 576	SL1SC3581	<b>769</b>	<b>828</b>	<b>904</b>	<b>923</b>	<b>836</b>
		Maniglia Slim   Slim handle		21	21	21	21	21
		Maniglia gola   Groove handle		105	105	105	105	105

Ulteriori combinazioni di aperture e finiture sono possibili utilizzando le scocche vuote a pag. | Additional finishes and opening combinations are possible using the empty bodies on page 59

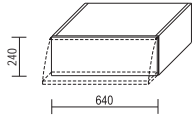
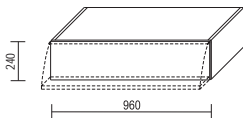
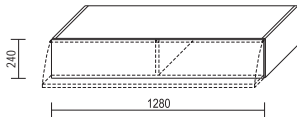
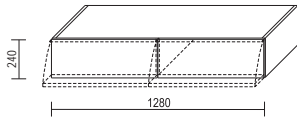
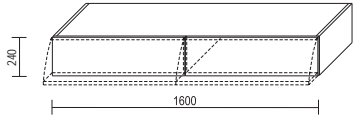
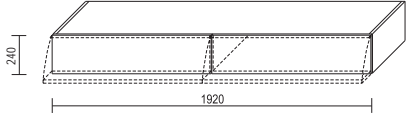
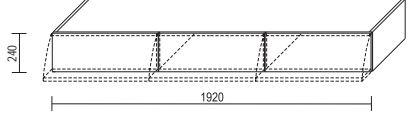

N.B: L'interno del mobile e del vano a giorno è in materico abbinato per il rovere termotrattato e nodi, in laccato opaco in tinta per i laccati, le superfici UP e per le essenze rovere gesso, visone, cenere e castoro

- Aggiungere sempre il top alle basi a pag.   Always add the top to the bases on page 72 - Apertura standard "push and pull"   Standard 'push and pull' opening - Possibile l'inserimento di braccetti a filo solo con maniglia, maggiorazione a pag. 118 Wire hinges can only be inserted in fronts with handles. Surcharge on page 118		codice	lacc. opaco	essenza cat. 1	essenza cat. 2	rovere lacc.	lacc. lucido	
		code	matt lacq.	wood cat. 1	wood cat. 2	matt lacq. oak	glossy lacq.	
							superfici UP	
							UP surface	
Base con 1 ribalta Base with 1 flap-door  	VOLm <sup>3</sup> Kg							
	0,095 10,5	P.   D. 480	SL1SR1431	<b>284</b>	<b>336</b>	<b>369</b>	<b>379</b>	<b>320</b>
	0,112 12	P.   D. 576	SL1SR1531	<b>302</b>	<b>353</b>	<b>386</b>	<b>399</b>	<b>339</b>
		Maniglia Slim   Slim handle Maniglia gola   Groove handle		16 39	16 39	16 39	16 39	16 39
Base con 1 ribalta Base with 1 flap-door  	VOLm <sup>3</sup> Kg							
	0,139 14	P.   D. 480	SL1SR1451	<b>352</b>	<b>407</b>	<b>448</b>	<b>461</b>	<b>390</b>
	0,164 16	P.   D. 576	SL1SR1551	<b>373</b>	<b>421</b>	<b>464</b>	<b>477</b>	<b>414</b>
		Maniglia Slim   Slim handle Maniglia gola   Groove handle		19 46	19 46	19 46	19 46	19 46
Base con 1 ribalta Base with 1 flap-door  	VOLm <sup>3</sup> Kg							
	0,182 19,5	P.   D. 480	SL1SR1461	<b>426</b>	<b>480</b>	<b>530</b>	<b>544</b>	<b>476</b>
	0,215 22,5	P.   D. 576	SL1SR1561	<b>454</b>	<b>500</b>	<b>551</b>	<b>568</b>	<b>503</b>
		Maniglia Slim   Slim handle Maniglia gola   Groove handle		30 51	30 51	30 51	30 51	30 51
Base con 2 ribalte Base with 2 flap-doors  	VOLm <sup>3</sup> Kg							
	0,182 20	P.   D. 480	SL1SR2461	<b>487</b>	<b>552</b>	<b>602</b>	<b>619</b>	<b>542</b>
	0,215 23	P.   D. 576	SL1SR2561	<b>515</b>	<b>572</b>	<b>623</b>	<b>643</b>	<b>569</b>
		Maniglia Slim   Slim handle Maniglia gola   Groove handle		32 78	32 78	32 78	32 78	32 78
Base con 2 ribalte Base with 2 flap-doors  	VOLm <sup>3</sup> Kg							
	0,225 23,5	P.   D. 480	SL1SR2471	<b>580</b>	<b>648</b>	<b>710</b>	<b>728</b>	<b>641</b>
	0,266 26,5	P.   D. 576	SL1SR2571	<b>617</b>	<b>679</b>	<b>743</b>	<b>761</b>	<b>678</b>
		Maniglia Slim   Slim handle Maniglia gola   Groove handle		36 86	36 86	36 86	36 86	36 86
Base con 2 ribalte Base with 2 flap-doors  	VOLm <sup>3</sup> Kg							
	0,268 26,5	P.   D. 480	SL1SR2481	<b>635</b>	<b>701</b>	<b>771</b>	<b>793</b>	<b>696</b>
	0,317 30	P.   D. 576	SL1SR2581	<b>673</b>	<b>733</b>	<b>803</b>	<b>827</b>	<b>736</b>
		Maniglia Slim   Slim handle Maniglia gola   Groove handle		38 92	38 92	38 92	38 92	38 92
Base con 3 ribalte Base with 3 flap-doors  	VOLm <sup>3</sup> Kg							
	0,268 29	P.   D. 480	SL1SR3481	<b>725</b>	<b>805</b>	<b>873</b>	<b>898</b>	<b>800</b>
	0,317 33	P.   D. 576	SL1SR3581	<b>766</b>	<b>837</b>	<b>907</b>	<b>932</b>	<b>842</b>
		Maniglia Slim   Slim handle Maniglia gola   Groove handle		48 117	48 117	48 117	48 117	48 117

Ulteriori combinazioni di aperture e finiture sono possibili utilizzando le scocche vuote a pag. | Additional finishes and opening combinations are possible using the empty bodies on page 59

N.B: The interior of the cabinet and open compartment has matching textured f. for heat-treated oak and oak knots finishes and matching matte lacquer for lacquers, UP surfaces, in addition to oak gesso, oak visone, oak cenere and oak castoro woods.

				codice	lacc. opaco	essenza cat. 1	essenza cat. 2	rovere lacc.	lacc. lucido	
				code	matt lacq.	wood cat. 1	wood cat. 2	matt lacq. oak	glossy lacq.	
									superfici UP	
									UP surface	
- Aggiungere sempre il top alle basi a pag.   Always add the top to the bases on page 72 - Apertura standard "push and pull"   Standard 'push and pull' opening - Possibile l'inserimento di braccetti a filo solo con maniglia, maggiorazione a pag. 118 Wire hinges can only be inserted in fronts with handles. Surcharge on page 118										
Base con 1 cassetto e 1 ribalta Base with 1 drawer and 1 flap-door										
		VOLm³	Kg	P.   D. 480						
		0,182	22	SX   LH	SL1SMS461	486	545	596	611	537
				DX   RH	SL1SMD461	486	545	596	611	537
		VOLm³	Kg	P.   D. 576						
		0,215	24,5	SX   LH	SL1SMS561	516	569	622	640	567
				DX   RH	SL1SMD561	516	569	622	640	567
				Maniglia Slim   Slim handle	23	23	23	23	23	
				Maniglia gola   Groove handle	74	74	74	74	74	
Base con 1 cassetto e 1 ribalta Base with 1 drawer and 1 flap-door										
		VOLm³	Kg	P.   D. 480						
		0,225	26	SX   LH	SL1SMS471	586	648	711	729	644
				DX   RH	SL1SMD471	586	648	711	729	644
		VOLm³	Kg	P.   D. 576						
		0,266	29,5	SX   LH	SL1SMS571	626	683	747	765	684
				DX   RH	SL1SMD571	626	683	747	765	684
				Maniglia Slim   Slim handle	25	25	25	25	25	
				Maniglia gola   Groove handle	80	80	80	80	80	
Base con 1 cassetto e 1 ribalta Base with 1 drawer and 1 flap-door										
		VOLm³	Kg	P.   D. 480						
		0,268	30	SX   LH	SL1SMS481	642	704	774	794	703
				DX   RH	SL1SMD481	642	704	774	794	703
		VOLm³	Kg	P.   D. 576						
		0,317	33,5	SX   LH	SL1SMS581	684	740	810	832	746
				DX   RH	SL1SMD581	684	740	810	832	746
				Maniglia Slim   Slim handle	27	27	27	27	27	
				Maniglia gola   Groove handle	85	85	85	85	85	

Ulteriori combinazioni di aperture e finiture sono possibili utilizzando le scocche vuote a pag. | Additional finishes and opening combinations are possible using the empty bodies on page 59

N.B: L'interno del mobile e del vano a giorno è in materico abbinato per il rovere termotrattato e nodi, in laccato opaco in tinta per i laccati, le superfici UP e per le essenze rovere gesso, visone, cenere e castoro

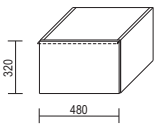
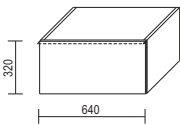
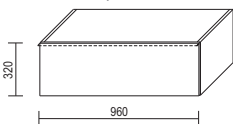
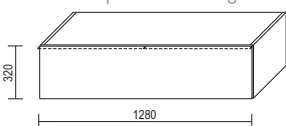
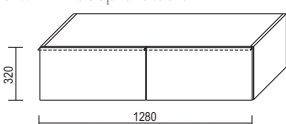
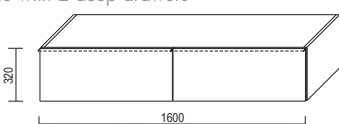
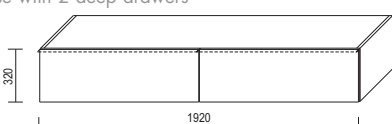
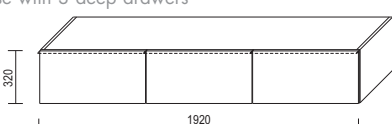
- Aggiungere sempre il top alle basi a pag.   Always add the top to the bases on page 72 - Apertura standard "push and pull"   Standard 'push and pull' opening		codice code	lacc. opaco matt lacq.	essenza cat. 1 wood cat. 1	essenza cat. 2 wood cat. 2	rovere lacc. matt lacq. oak	lacc. lucido glossy lacq.	superfici UP UP surface
Base con 1 cestone Base with 1 deep drawer 	VOLm <sup>3</sup> Kg							
	0,097 17	P.   D. 480	SL1SC1422	<b>264</b>	<b>299</b>	<b>337</b>	<b>348</b>	<b>302</b>
	0,115 21	P.   D. 576	SL1SC1522	<b>283</b>	<b>326</b>	<b>364</b>	<b>376</b>	<b>324</b>
		Maniglia Slim   Slim handle Maniglia gola   Groove handle		6 32	6 32	6 32	6 32	6 32
Base con 1 cestone Base with 1 deep drawer 	VOLm <sup>3</sup> Kg							
	0,127 21,5	P.   D. 480	SL1SC1432	<b>304</b>	<b>344</b>	<b>383</b>	<b>396</b>	<b>344</b>
	0,151 25,5	P.   D. 576	SL1SC1532	<b>324</b>	<b>368</b>	<b>411</b>	<b>423</b>	<b>369</b>
		Maniglia Slim   Slim handle Maniglia gola   Groove handle		7 35	7 35	7 35	7 35	7 35
Base con 1 cestone Base with 1 deep drawer 	VOLm <sup>3</sup> Kg							
	0,187 29	P.   D. 480	SL1SC1452	<b>382</b>	<b>422</b>	<b>470</b>	<b>486</b>	<b>429</b>
	0,222 33	P.   D. 576	SL1SC1552	<b>409</b>	<b>442</b>	<b>497</b>	<b>513</b>	<b>458</b>
		Maniglia Slim   Slim handle Maniglia gola   Groove handle		8 39	8 39	8 39	8 39	8 39
Base con 2 cestoni - frontale unico Base with 2 deep drawers - single front 	VOLm <sup>3</sup> Kg							
	0,247 42	P.   D. 480	SL1SC1462	<b>513</b>	<b>541</b>	<b>601</b>	<b>623</b>	<b>572</b>
	0,293 48,5	P.   D. 576	SL1SC1562	<b>546</b>	<b>579</b>	<b>642</b>	<b>662</b>	<b>608</b>
		Maniglia Slim   Slim handle Maniglia gola   Groove handle		12 43	12 43	12 43	12 43	12 43
Base con 2 cestoni Base with 2 deep drawers 	VOLm <sup>3</sup> Kg							
	0,247 42	P.   D. 480	SL1SC2462	<b>517</b>	<b>550</b>	<b>610</b>	<b>630</b>	<b>579</b>
	0,293 48,5	P.   D. 576	SL1SC2562	<b>548</b>	<b>587</b>	<b>653</b>	<b>672</b>	<b>615</b>
		Maniglia Slim   Slim handle Maniglia gola   Groove handle		14 70	14 70	14 70	14 70	14 70
Base con 2 cestoni Base with 2 deep drawers 	VOLm <sup>3</sup> Kg							
	0,307 49	P.   D. 480	SL1SC2472	<b>629</b>	<b>663</b>	<b>736</b>	<b>759</b>	<b>700</b>
	0,364 56	P.   D. 576	SL1SC2572	<b>676</b>	<b>714</b>	<b>788</b>	<b>810</b>	<b>748</b>
		Maniglia Slim   Slim handle Maniglia gola   Groove handle		14 74	14 74	14 74	14 74	14 74
Base con 2 cestoni Base with 2 deep drawers 	VOLm <sup>3</sup> Kg							
	0,367 56	P.   D. 480	SL1SC2482	<b>689</b>	<b>722</b>	<b>801</b>	<b>826</b>	<b>768</b>
	0,435 64	P.   D. 576	SL1SC2582	<b>737</b>	<b>776</b>	<b>856</b>	<b>882</b>	<b>818</b>
		Maniglia Slim   Slim handle Maniglia gola   Groove handle		16 78	16 78	16 78	16 78	16 78
Base con 3 cestoni Base with 3 deep drawers 	VOLm <sup>3</sup> Kg							
	0,367 61,5	P.   D. 480	SL1SC3482	<b>768</b>	<b>800</b>	<b>876</b>	<b>903</b>	<b>850</b>
	0,435 71,5	P.   D. 576	SL1SC3582	<b>816</b>	<b>852</b>	<b>941</b>	<b>965</b>	<b>906</b>
		Maniglia Slim   Slim handle Maniglia gola   Groove handle		21 105	21 105	21 105	21 105	21 105

Ulteriori combinazioni di aperture e finiture sono possibili utilizzando le scocche vuote a pag. | Additional finishes and opening combinations are possible using the empty bodies on page 59

N.B: The interior of the cabinet and open compartment has matching textured f. for heat-treated oak and oak knots finishes and matching matte lacquer for lacquers, UP surfaces, in addition to oak gesso, oak visone, oak cenere and oak castoro woods.

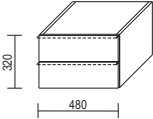
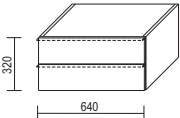
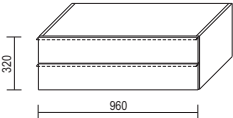
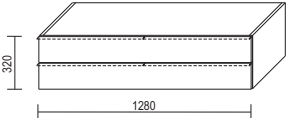
- Aggiungere sempre il top alle basi a pag.   Always add the top to the bases on page 72 - Apertura standard "push and pull"   Standard 'push and pull' opening - Non è possibile l'abbinamento di cassetti con maniglia insieme a cassetti apertura "push and pull" Drawers with handles cannot be combined with "push and pull"-opening drawers		codice	lacc. opaco	essenza cat. 1	essenza cat. 2	rovere lacc.	lacc. lucido		
		code	matt lacq.	wood cat. 1	wood cat. 2	matt lacq. oak	glossy lacq.		
							superfici UP UP surface		
Base con 2 cassetti Base with 2 drawers  		VOLm <sup>3</sup> Kg 0,097 20 0,115 23,5	P.   D. 480 P.   D. 576 Maniglia Slim   Slim handle Maniglia gola   Groove handle	SL1ST2422 SL1ST2522	331 351 12 64	371 396 12 64	416 443 12 64	431 460 12 64	367 391 12 64
Base con 2 cassetti Base with 2 drawers  		VOLm <sup>3</sup> Kg 0,127 24,5 0,151 29	P.   D. 480 P.   D. 576 Maniglia Slim   Slim handle Maniglia gola   Groove handle	SL1ST2432 SL1ST2532	378 402 14 70	425 451 14 70	477 506 14 70	497 524 14 70	421 446 14 70
Base con 2 cassetti Base with 2 drawers  		VOLm <sup>3</sup> Kg 0,187 32,5 0,222 36,5	P.   D. 480 P.   D. 576 Maniglia Slim   Slim handle Maniglia gola   Groove handle	SL1ST2452 SL1ST2552	472 501 16 78	519 537 16 78	578 607 16 78	602 629 16 78	524 555 16 78
Base con 4 cassetti - frontale unico Base with 4 drawers - single front  		VOLm <sup>3</sup> Kg 0,247 51 0,293 60	P.   D. 480 P.   D. 576 Maniglia Slim   Slim handle Maniglia gola   Groove handle	SL1ST2462 SL1ST2562	675 710 24 86	712 751 24 86	796 837 24 86	828 870 24 86	735 775 24 86

Ulteriori combinazioni di aperture e finiture sono possibili utilizzando le scocche vuote a pag. | Additional finishes and opening combinations are possible using the empty bodies on page 59

N.B: L'interno del mobile e del vano a giorno è in materico abbinato per il rovere termotrattato e nodi, in laccato opaco in tinta per i laccati, le superfici UP e per le essenze rovere gesso, visone, cenere e castoro

- Aggiungere sempre il top alle basi a pag. | Always add the top to the bases on page 72  
 - Apertura standard "push and pull" | Standard 'push and pull' opening

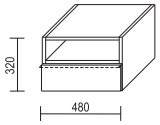
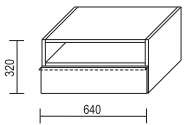
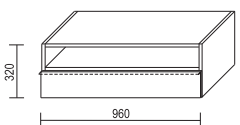
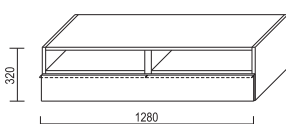
			<b>codice</b> code	<b>lacc. opaco</b> matt lacq.	<b>essenza cat. 1</b> wood cat. 1	<b>essenza cat. 2</b> wood cat. 2	<b>rovere lacc.</b> matt lacq. oak	<b>lacc. lucido</b> glossy lacq.	<b>superfici UP</b> UP surface
Base con 1 cassetto e 1 vano a giorno Base with 1 drawer and 1 open compartment  	VOLm <sup>3</sup> Kg								
	0,097 16,2	P.   D. 480	SL1ST1422	<b>303</b>	<b>319</b>	<b>366</b>	<b>376</b>	<b>332</b>	
	0,115 19,2	P.   D. 576	SL1ST1522	<b>328</b>	<b>345</b>	<b>397</b>	<b>409</b>	<b>361</b>	
		Maniglia Slim   Slim handle Maniglia gola   Groove handle			<b>6</b> <b>32</b>	<b>6</b> <b>32</b>	<b>6</b> <b>32</b>	<b>6</b> <b>32</b>	<b>6</b> <b>32</b>
Base con 1 cassetto e 1 vano a giorno Base with 1 drawer and 1 open compartment  	VOLm <sup>3</sup> Kg								
	0,127 19,8	P.   D. 480	SL1ST1432	<b>348</b>	<b>360</b>	<b>417</b>	<b>430</b>	<b>380</b>	
	0,151 23,8	P.   D. 576	SL1ST1532	<b>375</b>	<b>387</b>	<b>448</b>	<b>460</b>	<b>409</b>	
		Maniglia Slim   Slim handle Maniglia gola   Groove handle			<b>7</b> <b>35</b>	<b>7</b> <b>35</b>	<b>7</b> <b>35</b>	<b>7</b> <b>35</b>	<b>7</b> <b>35</b>
Base con 1 cassetto e 1 vano a giorno Base with 1 drawer and 1 open compartment  	VOLm <sup>3</sup> Kg								
	0,187 26	P.   D. 480	SL1ST1452	<b>441</b>	<b>445</b>	<b>509</b>	<b>524</b>	<b>477</b>	
	0,222 29,1	P.   D. 576	SL1ST1552	<b>476</b>	<b>465</b>	<b>542</b>	<b>556</b>	<b>514</b>	
		Maniglia Slim   Slim handle Maniglia gola   Groove handle			<b>8</b> <b>39</b>	<b>8</b> <b>39</b>	<b>8</b> <b>39</b>	<b>8</b> <b>39</b>	<b>8</b> <b>39</b>
Base con 2 cassetti (frontale unico) e 2 vani a giorno Base with 2 drawers (single front) and 2 open compartments  	VOLm <sup>3</sup> Kg								
	0,247 42,2	P.   D. 480	SL1ST1462	<b>610</b>	<b>582</b>	<b>677</b>	<b>696</b>	<b>652</b>	
	0,293 50	P.   D. 576	SL1ST1562	<b>653</b>	<b>624</b>	<b>724</b>	<b>744</b>	<b>698</b>	
		Maniglia Slim   Slim handle Maniglia gola   Groove handle			<b>12</b> <b>43</b>	<b>12</b> <b>43</b>	<b>12</b> <b>43</b>	<b>12</b> <b>43</b>	<b>12</b> <b>43</b>

Ulteriori combinazioni di aperture e finiture sono possibili utilizzando le scocche vuote a pag. | Additional finishes and opening combinations are possible using the empty bodies on page 59

N.B: The interior of the cabinet and open compartment has matching textured f. for heat-treated oak and oak knots finishes and matching matte lacquer for lacquers, UP surfaces, in addition to oak gesso, oak visone, oak cenere and oak castoro woods.

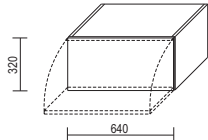
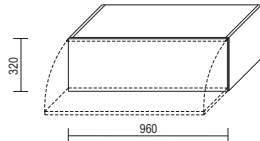
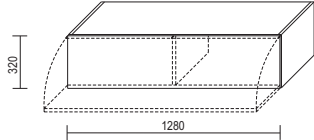
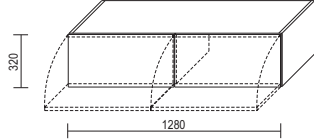
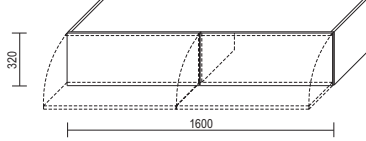
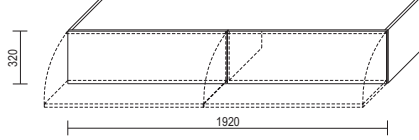
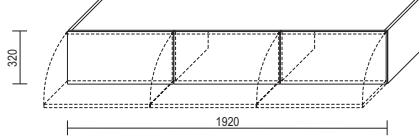
				<b>codice code</b>	<b>lacc. opaco matt lacq.</b>	<b>essenza cat. 1 wood cat. 1</b>	<b>essenza cat. 2 wood cat. 2</b>	<b>rovere lacc. matt lacq. oak</b>	<b>lacc. lucido glossy lacq.</b>	<b>superfici UP UP surface</b>
- Aggiungere sempre il top alle basi a pag.   Always add the top to the bases on page 72 - Apertura standard "push and pull"   Standard 'push and pull' opening - Possibile l'inserimento di braccetti a filo solo con maniglia, maggiorazione a pag. 118 Wire hinges can only be inserted in fronts with handles. Surcharge on page 118										
<b>Base con 1 ribalta</b> Base with 1 flap-door										
		VOL.m <sup>3</sup> Kg 0,127 16,5 0,151 19,5		P.   D. 480 P.   D. 576 Maniglia Slim   Slim handle Maniglia gola   Groove handle		SL1SR1432 SL1SR1532		<b>305 349 389 401 347</b> <b>323 369 410 422 368</b> 16 16 16 16 16 39 39 39 39 39		
<b>Base con 1 ribalta</b> Base with 1 flap-door										
		VOL.m <sup>3</sup> Kg 0,181 22,5 0,222 25		P.   D. 480 P.   D. 576 Maniglia Slim   Slim handle Maniglia gola   Groove handle		SL1SR1452 SL1SR1552		<b>373 415 465 481 419</b> <b>396 427 484 500 444</b> 19 19 19 19 19 46 46 46 46 46		
<b>Base con 1 ribalta</b> Base with 1 flap-door										
		VOL.m <sup>3</sup> Kg 0,247 31 0,293 35,5		P.   D. 480 P.   D. 576 Maniglia Slim   Slim handle Maniglia gola   Groove handle		SL1SR1462 SL1SR1562		<b>454 485 546 565 513</b> <b>481 514 575 595 541</b> 30 30 30 30 30 51 51 51 51 51		
<b>Base con 2 ribalte</b> Base with 2 flap-doors										
		VOL.m <sup>3</sup> Kg 0,247 31 0,293 35,5		P.   D. 480 P.   D. 576 Maniglia Slim   Slim handle Maniglia gola   Groove handle		SLSR2462 SLSR2562		<b>519 560 622 640 585</b> <b>546 589 651 670 613</b> 32 32 32 32 32 78 78 78 78 78		
<b>Base con 2 ribalte</b> Base with 2 flap-doors										
		VOL.m <sup>3</sup> Kg 0,307 36,5 0,364 41,5		P.   D. 480 P.   D. 576 Maniglia Slim   Slim handle Maniglia gola   Groove handle		SL1SR2472 SL1SR2572		<b>615 657 730 751 688</b> <b>654 696 768 790 728</b> 36 36 36 36 36 86 86 86 86 86		
<b>Base con 2 ribalte</b> Base with 2 flap-doors										
		VOL.m <sup>3</sup> Kg 0,367 42 0,435 48		P.   D. 480 P.   D. 576 Maniglia Slim   Slim handle Maniglia gola   Groove handle		SL1SR2482 SL1SR2582		<b>671 708 791 816 748</b> <b>711 746 830 856 790</b> 38 38 38 38 38 92 92 92 92 92		
<b>Base con 3 ribalte</b> Base with 3 flap-doors										
		VOL.m <sup>3</sup> Kg 0,367 45 0,435 52		P.   D. 480 P.   D. 576 Maniglia Slim   Slim handle Maniglia gola   Groove handle		SL1SR3482 SL1SR3582		<b>771 815 894 918 859</b> <b>813 855 938 962 903</b> 48 48 48 48 48 117 117 117 117 117		

Ulteriori combinazioni di aperture e finiture sono possibili utilizzando le scocche vuote a pag. | Additional finishes and opening combinations are possible using the empty bodies on page 59

N.B: L'interno del mobile e del vano a giorno è in materico abbinato per il rovere termotrattato e nodi, in laccato opaco in tinta per i laccati, le superfici UP e per le essenze rovere gesso, visone, cenere e castoro

				codice	lacc. opaco	essenza cat. 1	essenza cat. 2	rovere lacc.	lacc. lucido		
				code	matt lacq.	wood cat. 1	wood cat. 2	matt lacq. oak	glossy lacq.		
									superfici UP		
									UP surface		
Base con 1 cestone e 1 ribalta Base with 1 deep drawer and 1 flap-door											
	VOLm³	Kg	P.   D. 480								
			0,247	36	SX   LH	SL1SMS462	518	555	616	635	582
					DX   RH	SL1SMD462	518	555	616	635	582
	VOLm³	Kg	P.   D. 576								
			0,293	42	SX   LH	SL1SMS562	547	588	652	671	614
					DX   RH	SL1SMD562	547	588	652	671	614
				Maniglia Slim   Slim handle		23	23	23	23	23	
				Maniglia gola   Groove handle		74	74	74	74	74	
Base con 1 cestone e 1 ribalta Base with 1 deep drawer and 1 flap-door											
	VOLm³	Kg	P.   D. 480								
			0,307	42,5	SX   LH	SL1SMS472	622	660	733	755	694
					DX   RH	SL1SMD472	622	660	733	755	694
	VOLm³	Kg	P.   D. 576								
			0,364	48,5	SX   LH	SL1SMS572	665	705	778	800	738
					DX   RH	SL1SMD572	665	705	778	800	738
				Maniglia Slim   Slim handle		25	25	25	25	25	
				Maniglia gola   Groove handle		80	80	80	80	80	
Base con 1 cestone e 1 ribalta Base with 1 deep drawer and 1 flap-door											
	VOLm³	Kg	P.   D. 480								
			0,367	49	SX   LH	SL1SMS482	680	715	796	821	758
					DX   RH	SL1SMD482	680	715	796	821	758
	VOLm³	Kg	P.   D. 576								
			0,435	56	SX   LH	SL1SMS582	724	761	843	869	804
					DX   RH	SL1SMD582	724	761	843	869	804
				Maniglia Slim   Slim handle		27	27	27	27	27	
				Maniglia gola   Groove handle		85	85	85	85	85	

Ulteriori combinazioni di aperture e finiture sono possibili utilizzando le scocche vuote a pag. | Additional finishes and opening combinations are possible using the empty bodies on page 59

N.B: The interior of the cabinet and open compartment has matching textured f. for heat-treated oak and oak knots finishes and matching matte lacquer for lacquers, UP surfaces, in addition to oak gesso, oak visone, oak cenere and oak castoro woods.

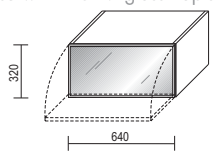
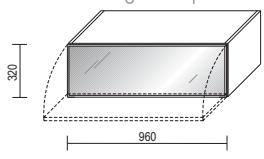
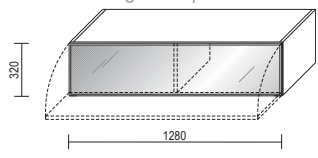
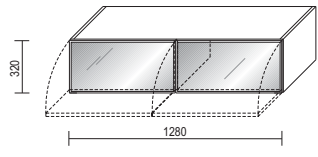
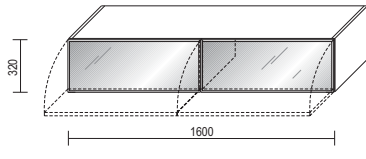
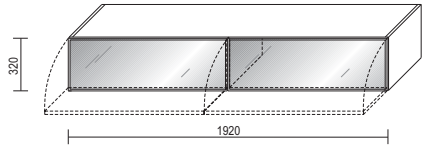
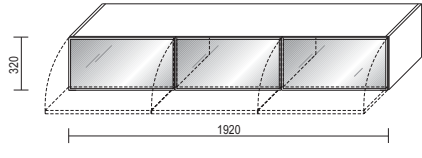
- Aggiungere sempre il top alle basi a pag.   Always add the top to the bases on page 72 - Solo apertura "push and pull"   Only "Push and pull" opening - Non è possibile l'inserimento di braccetti a filo   Lid supports cannot be inserted		codice	lacc. opaco	essenza cat. 1	essenza cat. 2	rovere lacc.	lacc. lucido	
		code	matt lacq.	wood cat. 1	wood cat. 2	matt lacq. oak	glossy lacq.	
							superfici UP UP surface	
Base con 1 ribalta vetro SLIM Base with 1 SLIM glass flap-door								
	VOLm <sup>3</sup> Kg							
	0,127 17	P.   D. 480 vetro   glass (cat 1)	SL1SV1432	<b>407</b>	<b>426</b>	<b>446</b>	<b>452</b>	<b>428</b>
		P.   D. 480 vetro   glass (cat 2)	SL1SV1432	<b>425</b>	<b>444</b>	<b>464</b>	<b>470</b>	<b>446</b>
	0,151 20	P.   D. 576 vetro   glass (cat 1)	SL1SV1532	<b>425</b>	<b>446</b>	<b>467</b>	<b>473</b>	<b>449</b>
		P.   D. 576 vetro   glass (cat 2)	SL1SV1532	<b>443</b>	<b>464</b>	<b>485</b>	<b>491</b>	<b>467</b>
Base con 1 ribalta vetro SLIM Base with 1 SLIM glass flap-door								
	VOLm <sup>3</sup> Kg							
	0,187 23	P.   D. 480 vetro   glass (cat 1)	SL1SV1452	<b>504</b>	<b>515</b>	<b>534</b>	<b>540</b>	<b>524</b>
		P.   D. 480 vetro   glass (cat 2)	SL1SV1452	<b>535</b>	<b>546</b>	<b>565</b>	<b>571</b>	<b>555</b>
	0,222 26	P.   D. 576 vetro   glass (cat 1)	SL1SV1552	<b>527</b>	<b>527</b>	<b>553</b>	<b>559</b>	<b>549</b>
		P.   D. 576 vetro   glass (cat 2)	SL1SV1552	<b>558</b>	<b>558</b>	<b>584</b>	<b>590</b>	<b>580</b>
Base con 1 ribalta vetro SLIM Base with 1 SLIM glass flap-door								
	VOLm <sup>3</sup> Kg							
	0,247 32	P.   D. 480 vetro   glass (cat 1)	SL1SV1462	<b>625</b>	<b>616</b>	<b>638</b>	<b>644</b>	<b>649</b>
		P.   D. 480 vetro   glass (cat 2)	SL1SV1462	<b>666</b>	<b>657</b>	<b>679</b>	<b>685</b>	<b>690</b>
	0,293 36,5	P.   D. 576 vetro   glass (cat 1)	SL1SV1562	<b>652</b>	<b>645</b>	<b>667</b>	<b>674</b>	<b>677</b>
		P.   D. 576 vetro   glass (cat 2)	SL1SV1562	<b>693</b>	<b>686</b>	<b>708</b>	<b>715</b>	<b>718</b>
Base con 2 ribalte vetro SLIM Base with 2 SLIM glass flap-doors								
	VOLm <sup>3</sup> Kg							
	0,247 32	P.   D. 480 vetro   glass (cat 1)	SL1SV2462	<b>723</b>	<b>714</b>	<b>736</b>	<b>742</b>	<b>747</b>
		P.   D. 480 vetro   glass (cat 2)	SL1SV2462	<b>759</b>	<b>750</b>	<b>772</b>	<b>778</b>	<b>783</b>
	0,293 36,5	P.   D. 576 vetro   glass (cat 1)	SL1SV2562	<b>750</b>	<b>743</b>	<b>765</b>	<b>772</b>	<b>775</b>
		P.   D. 576 vetro   glass (cat 2)	SL1SV2562	<b>786</b>	<b>779</b>	<b>801</b>	<b>808</b>	<b>811</b>
Base con 2 ribalte vetro SLIM Base with 2 SLIM glass flap-doors								
	VOLm <sup>3</sup> Kg							
	0,307 37,5	P.   D. 480 vetro   glass (cat 1)	SL1SV2472	<b>847</b>	<b>831</b>	<b>854</b>	<b>859</b>	<b>872</b>
		P.   D. 480 vetro   glass (cat 2)	SL1SV2472	<b>895</b>	<b>879</b>	<b>902</b>	<b>907</b>	<b>920</b>
	0,364 42,5	P.   D. 576 vetro   glass (cat 1)	SL1SV2572	<b>886</b>	<b>870</b>	<b>892</b>	<b>898</b>	<b>912</b>
		P.   D. 576 vetro   glass (cat 2)	SL1SV2572	<b>934</b>	<b>918</b>	<b>940</b>	<b>946</b>	<b>960</b>
Base con 2 ribalte vetro SLIM Base with 2 SLIM glass flap-doors								
	VOLm <sup>3</sup> Kg							
	0,367 43,5	P.   D. 480 vetro   glass (cat 1)	SL1SV2482	<b>933</b>	<b>908</b>	<b>929</b>	<b>934</b>	<b>958</b>
		P.   D. 480 vetro   glass (cat 2)	SL1SV2482	<b>995</b>	<b>970</b>	<b>991</b>	<b>996</b>	<b>1.020</b>
	0,435 49,5	P.   D. 576 vetro   glass (cat 1)	SL1SV2582	<b>973</b>	<b>946</b>	<b>968</b>	<b>974</b>	<b>1.000</b>
		P.   D. 576 vetro   glass (cat 2)	SL1SV2582	<b>1.035</b>	<b>1.008</b>	<b>1.030</b>	<b>1.036</b>	<b>1.062</b>
Base con 3 ribalte vetro SLIM Base with 3 SLIM glass flap-doors								
	VOLm <sup>3</sup> Kg							
	0,367 47	P.   D. 480 vetro   glass (cat 1)	SL1SV3482	<b>1.077</b>	<b>1.046</b>	<b>1.065</b>	<b>1.071</b>	<b>1.102</b>
		P.   D. 480 vetro   glass (cat 2)	SL1SV3482	<b>1.131</b>	<b>1.100</b>	<b>1.119</b>	<b>1.125</b>	<b>1.156</b>
	0,435 54	P.   D. 576 vetro   glass (cat 1)	SL1SV3582	<b>1.119</b>	<b>1.086</b>	<b>1.109</b>	<b>1.115</b>	<b>1.146</b>
		P.   D. 576 vetro   glass (cat 2)	SL1SV3582	<b>1.173</b>	<b>1.140</b>	<b>1.163</b>	<b>1.169</b>	<b>1.200</b>

Ulteriori combinazioni di aperture e finiture sono possibili utilizzando le scocche vuote a pag. | Additional finishes and opening combinations are possible using the empty bodies on page 59

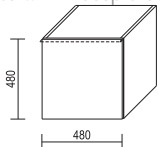
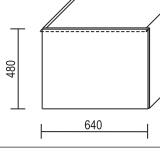
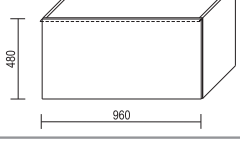
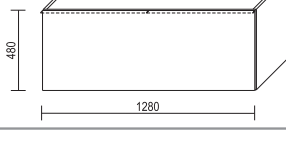
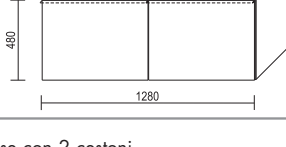
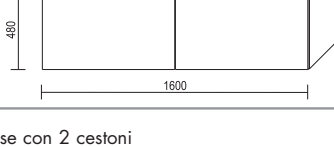
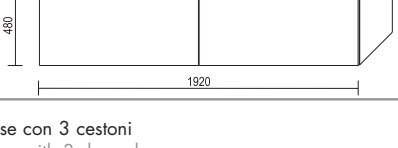
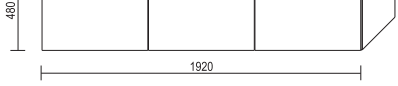

N.B: L'interno del mobile e del vano a giorno è in materico abbinato per il rovere termotrattato e nodi, in laccato opaco in tinta per i laccati, le superfici UP e per le essenze rovere gesso, visone, cenere e castoro

- Aggiungere sempre il top alle basi a pag.   Always add the top to the bases on page 72 - Apertura standard "push and pull"   Standard 'push and pull' opening		codice code	lacc. opaco matt lacq.	essenza cat. 1 wood cat. 1	essenza cat. 2 wood cat. 2	rovere lacc. matt lacq. oak	lacc. lucido glossy lacq.	superfici UP UP surface	
Base con 1 cestone Base with 1 deep drawer 	VOLm³	Kg							
	0,147	22	P.   D. 480	SL1SC1423	<b>307</b>	<b>343</b>	<b>387</b>	<b>403</b>	<b>373</b>
	0,173	24	P.   D. 576	SL1SC1523	<b>331</b>	<b>370</b>	<b>418</b>	<b>434</b>	<b>403</b>
			Maniglia Slim   Slim handle Maniglia gola   Groove handle		<b>6</b> <b>32</b>	<b>6</b> <b>32</b>	<b>6</b> <b>32</b>	<b>6</b> <b>32</b>	<b>6</b> <b>32</b>
Base con 1 cestone Base with 1 deep drawer 	VOLm³	Kg							
	0,190	26	P.   D. 480	SL1SC1433	<b>347</b>	<b>383</b>	<b>433</b>	<b>450</b>	<b>414</b>
	0,224	29	P.   D. 576	SL1SC1533	<b>371</b>	<b>415</b>	<b>471</b>	<b>489</b>	<b>450</b>
			Maniglia Slim   Slim handle Maniglia gola   Groove handle		<b>7</b> <b>35</b>	<b>7</b> <b>35</b>	<b>7</b> <b>35</b>	<b>7</b> <b>35</b>	<b>7</b> <b>35</b>
Base con 1 cestone Base with 1 deep drawer 	VOLm³	Kg							
	0,277	34	P.   D. 480	SL1SC1453	<b>433</b>	<b>480</b>	<b>544</b>	<b>566</b>	<b>512</b>
	0,327	39	P.   D. 576	SL1SC1553	<b>466</b>	<b>519</b>	<b>589</b>	<b>613</b>	<b>555</b>
			Maniglia Slim   Slim handle Maniglia gola   Groove handle		<b>8</b> <b>39</b>	<b>8</b> <b>39</b>	<b>8</b> <b>39</b>	<b>8</b> <b>39</b>	<b>8</b> <b>39</b>
Base con 2 cestoni - frontale unico Base with 2 deep drawers - single front 	VOLm³	Kg							
	0,363	49	P.   D. 480	SL1SC1463	<b>585</b>	<b>627</b>	<b>712</b>	<b>739</b>	<b>679</b>
	0,429	56	P.   D. 576	SL1SC1563	<b>624</b>	<b>679</b>	<b>770</b>	<b>798</b>	<b>732</b>
			Maniglia Slim   Slim handle Maniglia gola   Groove handle		<b>12</b> <b>43</b>	<b>12</b> <b>43</b>	<b>12</b> <b>43</b>	<b>12</b> <b>43</b>	<b>12</b> <b>43</b>
Base con 2 cestoni Base with 2 deep drawers 	VOLm³	Kg							
	0,363	49	P.   D. 480	SL1SC2463	<b>593</b>	<b>634</b>	<b>727</b>	<b>753</b>	<b>689</b>
	0,429	56	P.   D. 576	SL1SC2563	<b>629</b>	<b>689</b>	<b>785</b>	<b>814</b>	<b>743</b>
			Maniglia Slim   Slim handle Maniglia gola   Groove handle		<b>14</b> <b>70</b>	<b>14</b> <b>70</b>	<b>14</b> <b>70</b>	<b>14</b> <b>70</b>	<b>14</b> <b>70</b>
Base con 2 cestoni Base with 2 deep drawers 	VOLm³	Kg							
	0,450	58	P.   D. 480	SL1SC2473	<b>722</b>	<b>771</b>	<b>871</b>	<b>903</b>	<b>819</b>
	0,532	65	P.   D. 576	SL1SC2573	<b>775</b>	<b>827</b>	<b>932</b>	<b>964</b>	<b>872</b>
			Maniglia Slim   Slim handle Maniglia gola   Groove handle		<b>14</b> <b>74</b>	<b>14</b> <b>74</b>	<b>14</b> <b>74</b>	<b>14</b> <b>74</b>	<b>14</b> <b>74</b>
Base con 2 cestoni Base with 2 deep drawers 	VOLm³	Kg							
	0,536	66	P.   D. 480	SL1SC2483	<b>801</b>	<b>847</b>	<b>970</b>	<b>1.005</b>	<b>908</b>
	0,634	74	P.   D. 576	SL1SC2583	<b>855</b>	<b>906</b>	<b>1.022</b>	<b>1.061</b>	<b>966</b>
			Maniglia Slim   Slim handle Maniglia gola   Groove handle		<b>16</b> <b>78</b>	<b>16</b> <b>78</b>	<b>16</b> <b>78</b>	<b>16</b> <b>78</b>	<b>16</b> <b>78</b>
Base con 3 cestoni Base with 3 deep drawers 	VOLm³	Kg							
	0,536	72	P.   D. 480	SL1SC3483	<b>886</b>	<b>925</b>	<b>1.050</b>	<b>1.084</b>	<b>999</b>
	0,628	82	P.   D. 576	SL1SC3583	<b>942</b>	<b>992</b>	<b>1.121</b>	<b>1.159</b>	<b>1.066</b>
			Maniglia Slim   Slim handle Maniglia gola   Groove handle		<b>21</b> <b>105</b>	<b>21</b> <b>105</b>	<b>21</b> <b>105</b>	<b>21</b> <b>105</b>	<b>21</b> <b>105</b>

Ulteriori combinazioni di aperture e finiture sono possibili utilizzando le scocche vuote a pag. | Additional finishes and opening combinations are possible using the empty bodies on page 59

N.B: The interior of the cabinet and open compartment has matching textured f. for heat-treated oak and oak knots finishes and matching matte lacquer for lacquers, UP surfaces, in addition to oak gesso, oak visone, oak cenere and oak castoro woods.

- Aggiungere sempre il top alle basi a pag.   Always add the top to the bases on page 72 - Apertura standard "push and pull"   Standard 'push and pull' opening - Non è possibile l'abbinamento di cassetti con maniglia insieme a cassetti apertura "push and pull" Drawers with handles cannot be combined with "push and pull"-opening drawers	codice code	lacc. opaco matt lacq.	essenza cat. 1 wood cat. 1	essenza cat. 2 wood cat. 2	rovere lacc. matt lacq. oak	lacc. lucido glossy lacq.
						superfici UP UP surface

Base con 2 cassetti  
Base with 2 drawers

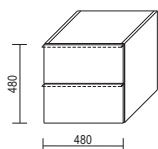

VOL.m<sup>3</sup> Kg  
0,147 24  
0,173 27

P.   D. 480	SL1ST2423	<b>371</b>	<b>422</b>	<b>471</b>	<b>487</b>	<b>435</b>
P.   D. 576	SL1ST2523	<b>399</b>	<b>449</b>	<b>502</b>	<b>521</b>	<b>469</b>
Maniglia Slim   Slim handle		12	12	12	12	12
Maniglia gola   Groove handle		64	64	64	64	64

Base con 2 cassetti  
Base with 2 drawers

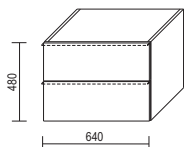

VOL.m<sup>3</sup> Kg  
0,119028  
0,224 32

P.   D. 480	SL1ST2433	<b>423</b>	<b>476</b>	<b>530</b>	<b>548</b>	<b>490</b>
P.   D. 576	SL1ST2533	<b>449</b>	<b>509</b>	<b>571</b>	<b>589</b>	<b>527</b>
Maniglia Slim   Slim handle		14	14	14	14	14
Maniglia gola   Groove handle		70	70	70	70	70

Base con 2 cassetti  
Base with 2 drawers

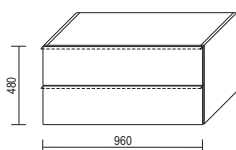

VOL.m<sup>3</sup> Kg  
0,227 35  
0,327 40

P.   D. 480	SL1ST2453	<b>523</b>	<b>589</b>	<b>664</b>	<b>686</b>	<b>605</b>
P.   D. 576	SL1ST2553	<b>560</b>	<b>629</b>	<b>708</b>	<b>731</b>	<b>649</b>
Maniglia Slim   Slim handle		16	16	16	16	16
Maniglia gola   Groove handle		78	78	78	78	78

Base con 4 cassetti - frontale unico  
Base with 4 drawers - single front

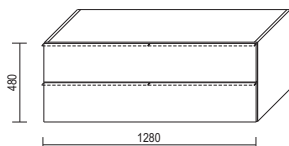

VOL.m<sup>3</sup> Kg  
0,363 52  
0,429 60

P.   D. 480	SL1ST2463	<b>743</b>	<b>812</b>	<b>913</b>	<b>941</b>	<b>837</b>
P.   D. 576	SL1ST2563	<b>783</b>	<b>863</b>	<b>971</b>	<b>1.002</b>	<b>891</b>
Maniglia Slim   Slim handle		24	24	24	24	24
Maniglia gola   Groove handle		86	86	86	86	86

Ulteriori combinazioni di aperture e finiture sono possibili utilizzando le scocche vuote a pag. | Additional finishes and opening combinations are possible using the empty bodies on page 59

N.B: L'interno del mobile e del vano a giorno è in materico abbinato per il rovere termotrattato e nodi, in laccato opaco in tinta per i laccati, le superfici UP e per le essenze rovere gesso, visone, cenere e castoro

- Aggiungere sempre il top alle basi a pag. | Always add the top to the bases on page 72  
 - Apertura standard "push and pull" | Standard 'push and pull' opening

codice code	lacc. opaco matt lacq.	essenza cat. 1 wood cat. 1	essenza cat. 2 wood cat. 2	rovere lacc. matt lacq. oak	lacc. lucido glossy lacq.	superfici UP UP surface
----------------	---------------------------	-------------------------------	-------------------------------	--------------------------------	------------------------------	----------------------------

Base con 1 cassetto e 1 vano a giorno  
 Base with 1 drawer and 1 open compartment

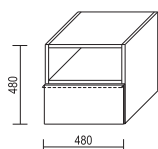

VOLm <sup>3</sup>	Kg	P.	D.	codice	lacc. opaco	essenza cat. 1	essenza cat. 2	rovere lacc.	lacc. lucido
0,147	19,1	P.	D. 480	SL1ST1423	339	357	405	417	391
0,173	21,6	P.	D. 576	SL1ST1523	371	385	440	454	429
				Maniglia Slim	6	6	6	6	6
				Maniglia gola	32	32	32	32	32

Base con 1 cassetto e 1 vano a giorno  
 Base with 1 drawer and 1 open compartment

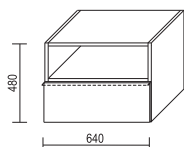

VOLm <sup>3</sup>	Kg	P.	D.	codice	lacc. opaco	essenza cat. 1	essenza cat. 2	rovere lacc.	lacc. lucido
0,190	22	P.	D. 480	SL1ST1433	385	395	452	465	438
0,224	25,4	P.	D. 576	SL1ST1533	415	428	494	507	478
				Maniglia Slim	7	7	7	7	7
				Maniglia gola	35	35	35	35	35

Base con 1 cassetto e 1 vano a giorno  
 Base with 1 drawer and 1 open compartment

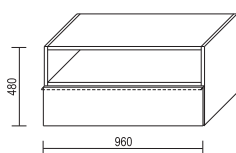

VOLm <sup>3</sup>	Kg	P.	D.	codice	lacc. opaco	essenza cat. 1	essenza cat. 2	rovere lacc.	lacc. lucido
0,277	26,9	P.	D. 480	SL1ST1453	482	492	566	581	543
0,327	31,2	P.	D. 576	SL1ST1553	524	533	615	631	593
				Maniglia Slim	8	8	8	8	8
				Maniglia gola	39	39	39	39	39

Base con 2 cassetti (frontale unico) e 2 vani a giorno  
 Base with 2 drawers (single front) and 2 open compartments

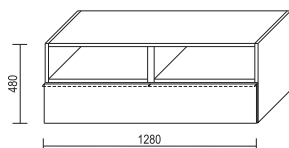

VOLm <sup>3</sup>	Kg	P.	D.	codice	lacc. opaco	essenza cat. 1	essenza cat. 2	rovere lacc.	lacc. lucido
0,362	41,1	P.	D. 480	SL1ST1463	668	654	761	779	735
0,429	47,9	P.	D. 576	SL1ST1563	716	708	824	844	796
				Maniglia Slim	12	12	12	12	12
				Maniglia gola	43	43	43	43	43

Ulteriori combinazioni di aperture e finiture sono possibili utilizzando le scocche vuote a pag. | Additional finishes and opening combinations are possible using the empty bodies on page 59

N.B: The interior of the cabinet and open compartment has matching textured f. for heat-treated oak and oak knots finishes and matching matte lacquer for lacquers, UP surfaces, in addition to oak gesso, oak visone, oak cenere and oak castoro woods.

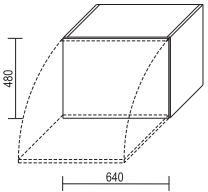
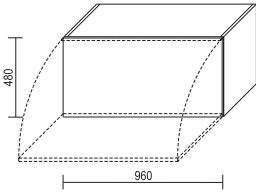
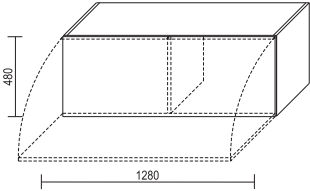
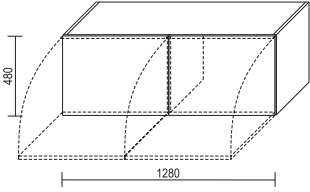
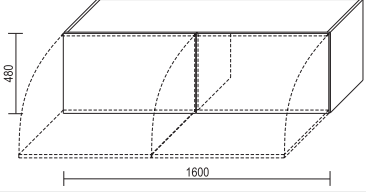
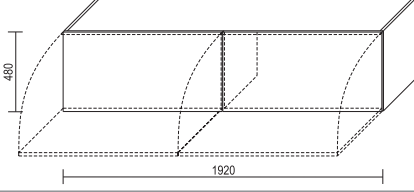
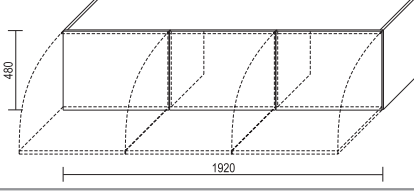
				codice	lacc. opaco	essenza cat. 1	essenza cat. 2	rovere lacc.	lacc. lucido
				code	matt lacq.	wood cat. 1	wood cat. 2	matt lacq. oak	glossy lacq.
									superfici UP
									UP surface
Base con 1 ribalta   Base with 1 flap-door									
	VOL.m <sup>3</sup>	Kg							
	0,190	21	P.   D. 480	SL1SR1433	<b>358</b>	<b>405</b>	<b>451</b>	<b>469</b>	<b>427</b>
	0,224	24	P.   D. 576	SL1SR1533	<b>380</b>	<b>430</b>	<b>482</b>	<b>500</b>	<b>458</b>
			Maniglia Slim   Slim handle		16	16	16	16	16
				Maniglia gola   Groove handle		39	39	39	39
Base con 1 ribalta   Base with 1 flap-door									
	VOL.m <sup>3</sup>	Kg							
	0,277	28	P.   D. 480	SL1SR1453	<b>434</b>	<b>485</b>	<b>551</b>	<b>573</b>	<b>512</b>
	0,327	32	P.   D. 576	SL1SR1553	<b>463</b>	<b>517</b>	<b>587</b>	<b>610</b>	<b>550</b>
			Maniglia Slim   Slim handle		19	19	19	19	19
				Maniglia gola   Groove handle		46	46	46	46
Base con 1 ribalta   Base with 1 flap-door									
	VOL.m <sup>3</sup>	Kg							
	0,363	39	P.   D. 480	SL1SR1463	<b>544</b>	<b>619</b>	<b>703</b>	<b>730</b>	<b>638</b>
	0,429	45	P.   D. 576	SL1SR1563	<b>576</b>	<b>660</b>	<b>747</b>	<b>775</b>	<b>682</b>
			Maniglia Slim   Slim handle		30	30	30	30	30
				Maniglia gola   Groove handle		51	51	51	51
Base con 2 ribalte   Base with 2 flap-door									
	VOL.m <sup>3</sup>	Kg							
	0,363	40	P.   D. 480	SL1SR2463	<b>615</b>	<b>678</b>	<b>763</b>	<b>791</b>	<b>715</b>
	0,429	45	P.   D. 576	SL1SR2563	<b>647</b>	<b>719</b>	<b>807</b>	<b>836</b>	<b>759</b>
			Maniglia Slim   Slim handle		32	32	32	32	32
				Maniglia gola   Groove handle		78	78	78	78
Base con 2 ribalte   Base with 2 flap-door									
	VOL.m <sup>3</sup>	Kg							
	0,450	47	P.   D. 480	SL1SR2473	<b>734</b>	<b>795</b>	<b>895</b>	<b>927</b>	<b>833</b>
	0,532	53	P.   D. 576	SL1SR2573	<b>779</b>	<b>837</b>	<b>942</b>	<b>974</b>	<b>880</b>
			Maniglia Slim   Slim handle		36	36	36	36	36
				Maniglia gola   Groove handle		86	86	86	86
Base con 2 ribalte   Base with 2 flap-door									
	VOL.m <sup>3</sup>	Kg							
	0,536	53	P.   D. 480	SL1SR2483	<b>803</b>	<b>857</b>	<b>984</b>	<b>1.019</b>	<b>908</b>
	0,634	60	P.   D. 576	SL1SR2583	<b>849</b>	<b>902</b>	<b>1.018</b>	<b>1.055</b>	<b>956</b>
			Maniglia Slim   Slim handle		38	38	38	38	38
				Maniglia gola   Groove handle		92	92	92	92
Base con 3 ribalte   Base with 3 flap-door									
	VOL.m <sup>3</sup>	Kg							
	0,536	58	P.   D. 480	SL1SR3483	<b>919</b>	<b>991</b>	<b>1.104</b>	<b>1.141</b>	<b>1.038</b>
	0,634	66	P.   D. 576	SL1SR3583	<b>969</b>	<b>1.037</b>	<b>1.154</b>	<b>1.192</b>	<b>1.090</b>
			Maniglia Slim   Slim handle		48	48	48	48	48
				Maniglia gola   Groove handle		117	117	117	117

Ulteriori combinazioni di aperture e finiture sono possibili utilizzando le scocche vuote a pag. | Additional finishes and opening combinations are possible using the empty bodies on page 59

N.B: L'interno del mobile e del vano a giorno è in materico abbinato per il rovere termotrattato e nodi, in laccato opaco in tinta per i laccati, le superfici UP e per le essenze rovere gesso, visone, cenere e castoro

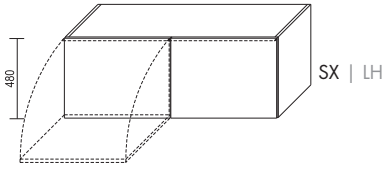
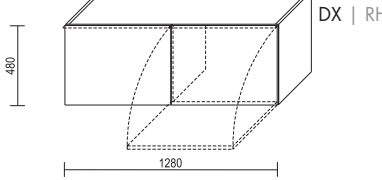
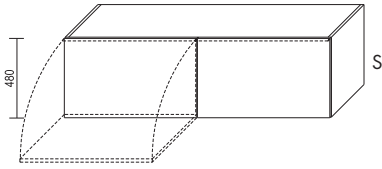
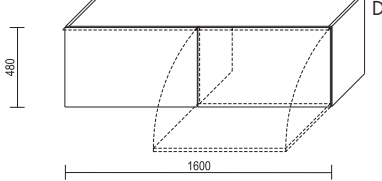
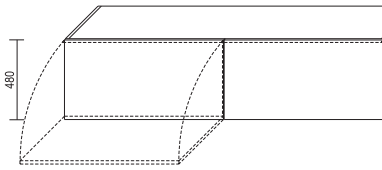
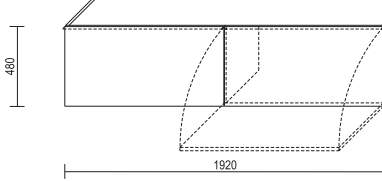
		codice code	lacc. opaco matt lacq.	essenza cat. 1 wood cat. 1	essenza cat. 2 wood cat. 2	rovere lacc. matt lacq. oak	lacc. lucido glossy lacq.	superfici UP UP surface
<p>- Aggiungere sempre il top alle basi a pag.   Always add the top to the bases on page 72</p> <p>- Apertura standard "push and pull"   Standard 'push and pull' opening</p> <p>- Opzionale, ripiano retro ribalta interno in vetro o legno, vedi pag.   Optional equipment: internal glass or wooden shelf, to be positioned behind the flap door, check page 66</p> <p>- Possibile l'inserimento di braccetti a filo solo con maniglia, maggiorazione a pag. 118</p> <p>Wire hinges can only be inserted in fronts with handles. Surcharge on page 118</p>								
<p>Base con 1 cestone e 1 ribalta Base with 1 deep drawer and 1 flap-door</p>								
	<p>VOLm<sup>3</sup> Kg</p> <p>0,363 44</p>	P.   D. 480						
		SX   LH	SL1SMS463	604	656	745	772	702
	<p>VOLm<sup>3</sup> Kg</p> <p>0,429 49</p>	P.   D. 576						
		SX   LH	SL1SMS563	638	704	796	825	751
		DX   RH	SL1SMD563	638	704	796	825	751
		Maniglia Slim   Slim handle	23	23	23	23	23	23
		Maniglia gola   Groove handle	74	74	74	74	74	74
<p>Base con 1 cestone e 1 ribalta Base with 1 deep drawer and 1 flap-door</p>								
	<p>VOLm<sup>3</sup> Kg</p> <p>0,450 52</p>	P.   D. 480						
		SX   LH	SL1SMS473	728	783	883	915	826
	<p>VOLm<sup>3</sup> Kg</p> <p>0,532 59</p>	P.   D. 576						
		SX   LH	SL1SMS573	777	832	937	969	876
		DX   RH	SL1SMD573	777	832	937	969	876
		Maniglia Slim   Slim handle	25	25	25	25	25	25
		Maniglia gola   Groove handle	80	80	80	80	80	80
<p>Base con 1 cestone e 1 ribalta Base with 1 deep drawer and 1 flap-door</p>								
	<p>VOLm<sup>3</sup> Kg</p> <p>0,536 60</p>	P.   D. 480						
		SX   LH	SL1SMS483	833	881	994	1.029	939
	<p>VOLm<sup>3</sup> Kg</p> <p>0,634 67</p>	P.   D. 576						
		SX   LH	SL1SMS583	887	934	1.053	1.090	996
		DX   RH	SL1SMD583	887	934	1.053	1.090	996
		Maniglia Slim   Slim handle	27	27	27	27	27	27
		Maniglia gola   Groove handle	85	85	85	85	85	85

Ulteriori combinazioni di aperture e finiture sono possibili utilizzando le scocche vuote a pag. | Additional finishes and opening combinations are possible using the empty bodies on page 59

N.B: The interior of the cabinet and open compartment has matching textured f. for heat-treated oak and oak knots finishes and matching matte lacquer for lacquers, UP surfaces, in addition to oak gesso, oak visone, oak cenere and oak castoro woods.

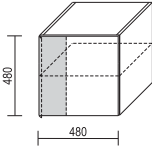
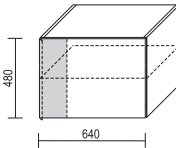
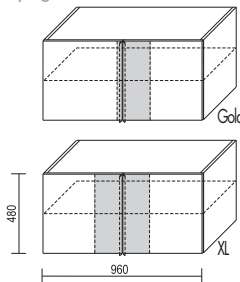
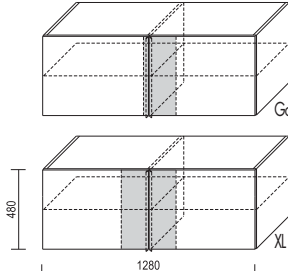
- Aggiungere sempre il top agli elementi a pag.   Always add the top to the elements on page 72		codice code	lacc. opaco matt lacq.	essenza cat. 1 wood cat. 1	essenza cat. 2 wood cat. 2	rovere lacc. matt lacq. oak	lacc. lucido glossy lacq.	superfici UP UP surface
- Apertura standard "push and pull"   Standard 'push and pull' opening								
- Specificare nell'ordine se a terra o in appoggio   In the order, specify whether positioned free-standing or supported								
<p>Elemento con 1 anta specificare nell'ordine se apertura dx o sx, sempre ripiano vetro dietro l'anta Element with 1 door in the order, specify if the opening is rh or lh, always glass shelf behind the door</p>								
	VOLm³ Kg							
	0,157 21	P.   D. 480	SL1BBL423	<b>286</b>	<b>321</b>	<b>355</b>	<b>370</b>	<b>349</b>
	0,185 25	P.   D. 576	SL1BBL523	<b>308</b>	<b>345</b>	<b>378</b>	<b>395</b>	<b>378</b>
		Maniglia Slim   Slim handle		10	10	10	10	10
		Maniglia gola   Groove handle		37	37	37	37	37
		Maniglia XL   XL handle		38	38	38	38	38
<p>Elemento con 1 anta specificare nell'ordine se apertura dx o sx, sempre ripiano vetro dietro l'anta Element with 1 door in the order, specify if the opening is rh or lh, always glass shelf behind the door</p>								
	VOLm³ Kg							
	0,204 26	P.   D. 480	SL1BBL433	<b>313</b>	<b>348</b>	<b>385</b>	<b>402</b>	<b>381</b>
	0,241 30	P.   D. 576	SL1BBL533	<b>335</b>	<b>374</b>	<b>414</b>	<b>432</b>	<b>414</b>
		Maniglia Slim   Slim handle		10	10	10	10	10
		Maniglia gola   Groove handle		37	37	37	37	37
		Maniglia XL   XL handle		38	38	38	38	38
<p>Elemento con 2 ante sempre ripiano vetro dietro le ante Element with 2 doors always glass shelf behind the doors</p>								
	VOLm³ Kg							
	0,297 37	P.   D. 480	SL1BBL453	<b>430</b>	<b>477</b>	<b>528</b>	<b>552</b>	<b>515</b>
	0,351 42	P.   D. 576	SL1BBL553	<b>459</b>	<b>513</b>	<b>564</b>	<b>588</b>	<b>556</b>
		Maniglia Slim   Slim handle		20	20	20	20	20
		Maniglia gola   Groove handle		74	74	74	74	74
		Maniglia XL   XL handle		76	76	76	76	76
		Gola + XL   Groove + XL		75	75	75	75	75
<p>Elemento con 2 ante sempre ripiani vetro dietro le ante Element with 2 doors always glass shelves behind the doors</p>								
	VOLm³ Kg							
	0,377 50	P.   D. 480	SL1BBL463	<b>524</b>	<b>567</b>	<b>629</b>	<b>656</b>	<b>624</b>
	0,446 58	P.   D. 576	SL1BBL563	<b>558</b>	<b>609</b>	<b>673</b>	<b>702</b>	<b>670</b>
		Maniglia Slim   Slim handle		20	20	20	20	20
		Maniglia gola   Groove handle		74	74	74	74	74
		Maniglia XL   XL handle		76	76	76	76	76
		Gola + XL   Groove + XL		75	75	75	75	75

Ulteriori combinazioni di aperture e finiture sono possibili utilizzando le scocche vuote a pag. | Additional finishes and opening combinations are possible using the empty bodies on page 67

N.B: L'interno del mobile e del vano a giorno è in materico abbinato per il rovere termotrattato e nodi, in laccato opaco in tinta per i laccati, le superfici UP e per le essenze rovere gesso, visone, cenere e castoro

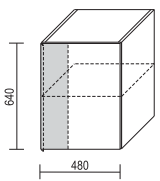
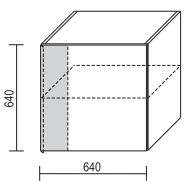
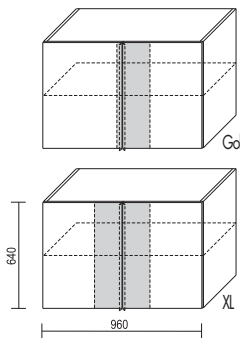
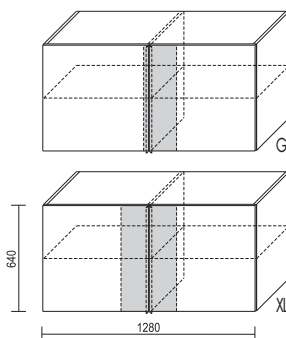
- Aggiungere sempre il top agli elementi a pag.   Always add the top for to elements on page 72		codice	lacc. opaco	essenza cat. 1	essenza cat. 2	rovere lacc.	lacc. lucido
- Apertura standard "push and pull"   Standard 'push and pull' opening		code	matt lacq.	wood cat. 1	wood cat. 2	matt lacq. oak	glossy lacq.
- Specificare nell'ordine se a terra o in appoggio   In the order, specify whether positioned free-standing or supported							superfici UP UP surface
<p>Elemento con 1 anta specificare nell'ordine se apertura dx o sx, sempre ripiano vetro dietro l'anta Element with 1 door in the order, specify if the opening is rh or lh, always glass shelf behind the door</p> 							
VOLm³	Kg						
0,184	23,5	P.   D. 480	SL1BBL424	<b>312</b>	<b>350</b>	<b>387</b>	<b>407</b>
0,218	26	P.   D. 576	SL1BBL524	<b>334</b>	<b>376</b>	<b>415</b>	<b>437</b>
		Maniglia Slim   Slim handle		11	11	11	11
		Maniglia gola   Groove handle		39	39	39	39
		Maniglia XL   XL handle		44	44	44	44
<p>Elemento con 1 anta specificare nell'ordine se apertura dx o sx, sempre ripiano vetro dietro l'anta Element with 1 door in the order, specify if the opening is rh or lh, always glass shelf behind the door</p> 							
VOLm³	Kg						
0,240	27,5	P.   D. 480	SL1BBL434	<b>343</b>	<b>385</b>	<b>427</b>	<b>449</b>
0,285	32,5	P.   D. 576	SL1BBL534	<b>368</b>	<b>413</b>	<b>458</b>	<b>482</b>
		Maniglia Slim   Slim handle		11	11	11	11
		Maniglia gola   Groove handle		39	39	39	39
		Maniglia XL   XL handle		44	44	44	44
<p>Elemento con 2 ante, sempre ripiano vetro dietro le ante Element with 2 doors, always glass shelf behind the doors</p> 							
VOLm³	Kg						
0,354	38	P.   D. 480	SL1BBL454	<b>468</b>	<b>523</b>	<b>582</b>	<b>612</b>
0,419	44	P.   D. 576	SL1BBL554	<b>499</b>	<b>560</b>	<b>621</b>	<b>652</b>
		Maniglia Slim   Slim handle		22	22	22	22
		Maniglia gola   Groove handle		78	78	78	78
		Maniglia XL   XL handle		88	88	88	88
		Gola + XL   Groove + XL		83	83	83	83
<p>Elemento con 2 ante, sempre ripiani vetro dietro le ante Element with 2 doors, always glass shelves behind the doors</p> 							
VOLm³	Kg						
0,467	56,5	P.   D. 480	SL1BBL464	<b>575</b>	<b>628</b>	<b>700</b>	<b>733</b>
0,553	64	P.   D. 576	SL1BBL564	<b>614</b>	<b>673</b>	<b>749</b>	<b>785</b>
		Maniglia Slim   Slim handle		22	22	22	22
		Maniglia gola   Groove handle		78	78	78	78
		Maniglia XL   XL handle		88	88	88	88
		Gola + XL   Groove + XL		83	83	83	83

Ulteriori combinazioni di aperture e finiture sono possibili utilizzando le scocche vuote a pag. | Additional finishes and opening combinations are possible using the empty bodies on page 67

N.B: The interior of the cabinet and open compartment has matching textured f. for heat-treated oak and oak knots finishes and matching matte lacquer for lacquers, UP surfaces, in addition to oak gesso, oak visone, oak cenere and oak castoro woods.

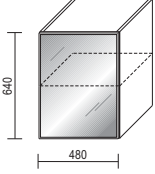
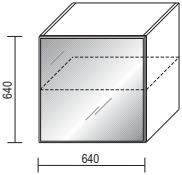
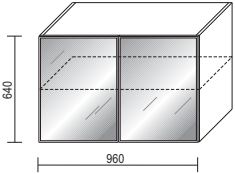
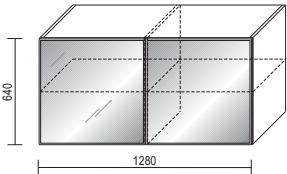
- Aggiungere sempre il top agli elementi a pag.   Always add the top to the elements on page 72		codice code	lacc. opaco matt lacq.	essenza cat. 1 wood cat. 1	essenza cat. 2 wood cat. 2	rovere lacc. matt lacq. oak	lacc. lucido glossy lacq.	superfici UP UP surface
- Solo apertura "push and pull"   Only "Push and pull" opening								
- Specificare nell'ordine se a terra o in appoggio   In the order, specify whether positioned free-standing or supported								
<p>Elemento con 1 anta vetro SLIM specificare nell'ordine se apertura dx o sx, sempre ripiano vetro dietro l'anta Element with 1 SLIM glass door in the order, specify if the opening is rh or lh, always glass shelf behind the door</p> 								
VOL.m <sup>3</sup>	Kg							
0,184	24,5	P.   D. 480 vetro   glass (cat 1)	SL1BBV424	<b>430</b>	<b>441</b>	<b>462</b>	<b>472</b>	<b>473</b>
		P.   D. 480 vetro   glass (cat 2)	SL1BBV424	<b>465</b>	<b>476</b>	<b>497</b>	<b>507</b>	<b>508</b>
0,218	27	P.   D. 576 vetro   glass (cat 1)	SL1BBV524	<b>452</b>	<b>467</b>	<b>490</b>	<b>502</b>	<b>504</b>
		P.   D. 576 vetro   glass (cat 2)	SL1BBV524	<b>487</b>	<b>502</b>	<b>525</b>	<b>537</b>	<b>539</b>
<p>Elemento con 1 anta vetro SLIM specificare nell'ordine se apertura dx o sx, sempre ripiano vetro dietro l'anta Element with 1 SLIM glass door in the order, specify if the opening is rh or lh, always glass shelf behind the door</p> 								
VOL.m <sup>3</sup>	Kg							
0,240	28,5	P.   D. 480 vetro   glass (cat 1)	SL1BBV434	<b>477</b>	<b>485</b>	<b>507</b>	<b>517</b>	<b>518</b>
		P.   D. 480 vetro   glass (cat 2)	SL1BBV434	<b>523</b>	<b>531</b>	<b>553</b>	<b>563</b>	<b>564</b>
0,285	33,5	P.   D. 576 vetro   glass (cat 1)	SL1BBV534	<b>502</b>	<b>513</b>	<b>538</b>	<b>550</b>	<b>552</b>
		P.   D. 576 vetro   glass (cat 2)	SL1BBV534	<b>548</b>	<b>559</b>	<b>584</b>	<b>596</b>	<b>598</b>
<p>Elemento con 2 ante vetro SLIM sempre ripiano vetro dietro le ante Element with 2 SLIM glass doors always glass shelf behind the doors</p> 								
VOL.m <sup>3</sup>	Kg							
0,354	39	P.   D. 480 vetro   glass (cat 1)	SL1BBV454	<b>704</b>	<b>705</b>	<b>732</b>	<b>742</b>	<b>746</b>
		P.   D. 480 vetro   glass (cat 2)	SL1BBV454	<b>774</b>	<b>775</b>	<b>802</b>	<b>812</b>	<b>816</b>
0,419	46	P.   D. 576 vetro   glass (cat 1)	SL1BBV554	<b>735</b>	<b>742</b>	<b>771</b>	<b>782</b>	<b>790</b>
		P.   D. 576 vetro   glass (cat 2)	SL1BBV554	<b>805</b>	<b>812</b>	<b>841</b>	<b>852</b>	<b>860</b>
<p>Elemento con 2 ante vetro SLIM sempre ripiani vetro dietro le ante Element with 2 SLIM glass doors always glass shelves behind the doors</p> 								
VOL.m <sup>3</sup>	Kg							
0,467	58,5	P.   D. 480 vetro   glass (cat 1)	SL1BBV464	<b>843</b>	<b>828</b>	<b>860</b>	<b>869</b>	<b>887</b>
		P.   D. 480 vetro   glass (cat 2)	SL1BBV464	<b>935</b>	<b>920</b>	<b>952</b>	<b>961</b>	<b>979</b>
0,553	66	P.   D. 576 vetro   glass (cat 1)	SL1BBV564	<b>882</b>	<b>873</b>	<b>909</b>	<b>921</b>	<b>938</b>
		P.   D. 576 vetro   glass (cat 2)	SL1BBV564	<b>974</b>	<b>965</b>	<b>1.001</b>	<b>1.013</b>	<b>1.030</b>

Ulteriori combinazioni di aperture e finiture sono possibili utilizzando le scocche vuote a pag. | Additional finishes and opening combinations are possible using the empty bodies on page 67

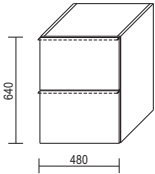
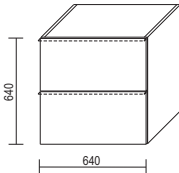
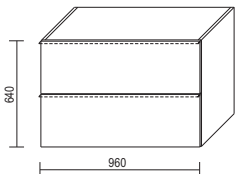
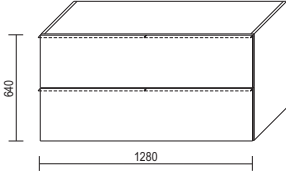
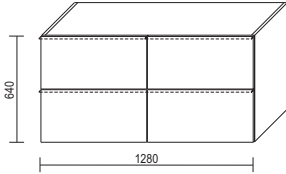

N.B: L'interno del mobile e del vano a giorno è in materico abbinato per il rovere termotrattato e nodi, in laccato opaco in tinta per i laccati, le superfici UP e per le essenze rovere gesso, visone, cenere e castoro

- Aggiungere sempre il top agli elementi a pag.   Always add the top to the elements on page 72 - Apertura standard "push and pull"   Standard 'push and pull' opening - Specificare nell'ordine se a terra o in appoggio   In the order, specify whether positioned free-standing or supported - Non è possibile l'abbinamento di cassetti con maniglia insieme a cassetti apertura "push and pull"   Drawers with handles cannot be combined with "push and pull"-opening drawers		codice	lacc. opaco	essenza cat. 1	essenza cat. 2	rovere lacc.	lacc. lucido		
		code	matt lacq.	wood cat. 1	wood cat. 2	matt lacq. oak	glossy lacq.		
							superfici UP		
							UP surface		
Elemento con 2 cestoni Element with 2 deep drawers									
	VOLm³	Kg							
	0,184	29	P.   D. 480	SL1BC2424	<b>394</b>	<b>435</b>	<b>490</b>	<b>512</b>	<b>469</b>
	0,218	32,5	P.   D. 576	SL1BC2524	<b>420</b>	<b>471</b>	<b>528</b>	<b>550</b>	<b>502</b>
			Maniglia Slim   Slim handle		12	12	12	12	12
				Maniglia gola   Groove handle	64	64	64	64	64
Elemento con 2 cestoni Element with 2 deep drawers									
	VOLm³	Kg							
	0,240	33	P.   D. 480	SL1BC2434	<b>445</b>	<b>495</b>	<b>555</b>	<b>579</b>	<b>524</b>
	0,285	38,5	P.   D. 576	SL1BC2534	<b>471</b>	<b>528</b>	<b>597</b>	<b>621</b>	<b>563</b>
			Maniglia Slim   Slim handle		14	14	14	14	14
				Maniglia gola   Groove handle	70	70	70	70	70
Elemento con 2 cestoni Element with 2 deep drawers									
	VOLm³	Kg							
	0,354	42,5	P.   D. 480	SL1BC2454	<b>551</b>	<b>610</b>	<b>695</b>	<b>725</b>	<b>647</b>
	0,419	50	P.   D. 576	SL1BC2554	<b>585</b>	<b>658</b>	<b>745</b>	<b>776</b>	<b>694</b>
			Maniglia Slim   Slim handle		16	16	16	16	16
				Maniglia gola   Groove handle	78	78	78	78	78
Elemento con 4 cestoni - frontale unico Element with 4 deep drawers - single front									
	VOLm³	Kg							
	0,467	67,5	P.   D. 480	SL1BC2464	<b>771</b>	<b>830</b>	<b>938</b>	<b>979</b>	<b>885</b>
	0,553	76	P.   D. 576	SL1BC2564	<b>816</b>	<b>887</b>	<b>1.005</b>	<b>1.043</b>	<b>946</b>
			Maniglia Slim   Slim handle		24	24	24	24	24
				Maniglia gola   Groove handle	86	86	86	86	86
Elemento con 4 cestoni Element with 4 deep drawers									
	VOLm³	Kg							
	0,467	67,5	P.   D. 480	SL1BC4464	<b>779</b>	<b>848</b>	<b>956</b>	<b>993</b>	<b>899</b>
	0,553	76	P.   D. 576	SL1BC4564	<b>820</b>	<b>903</b>	<b>1.027</b>	<b>1.063</b>	<b>960</b>
			Maniglia Slim   Slim handle		28	28	28	28	28
				Maniglia gola   Groove handle	140	140	140	140	140

Ulteriori combinazioni di aperture e finiture sono possibili utilizzando le scocche vuote a pag. | Additional finishes and opening combinations are possible using the empty bodies on page 67

N.B: The interior of the cabinet and open compartment has matching textured f. for heat-treated oak and oak knots finishes and matching matte lacquer for lacquers, UP surfaces, in addition to oak gesso, oak visone, oak cenere and oak castoro woods.

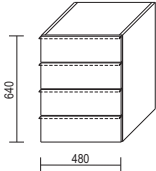
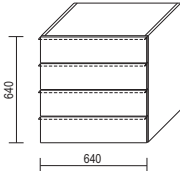
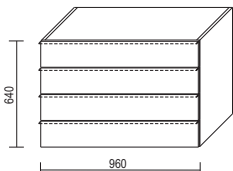
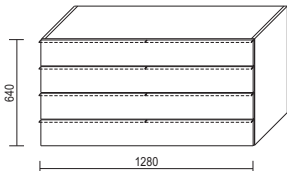
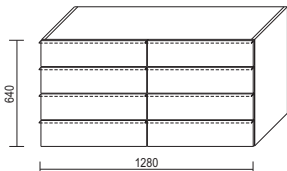
				codice code	lacc. opaco matt lacq.	essenza cat. 1 wood cat. 1	essenza cat. 2 wood cat. 2	rovere lacc. matt lacq. oak	lacc. lucido glossy lacq.
- Aggiungere sempre il top agli elementi a pag.   Always add the top to the elements on page 72 - Apertura standard "push and pull"   Standard 'push and pull' opening - Specificare nell'ordine se a terra o in appoggio   In the order, specify whether positioned free-standing or supported - Non è possibile l'abbinamento di cassetti con maniglia insieme a cassetti apertura "push and pull"   Drawers with handles cannot be combined with "push and pull"-opening drawers									superfici UP UP surface
Elemento con 4 cassetti Element with 4 drawers									
		VOL.m <sup>3</sup>	Kg						
		0,184	33,5	P.   D. 480	SL1BT4424	528	579	648	678
		0,218	38	P.   D. 576	SL1BT4524	556	611	686	718
				Maniglia Slim   Slim handle		24	24	24	24
				Maniglia gola   Groove handle		128	128	128	128
Elemento con 4 cassetti Element with 4 drawers									
		VOL.m <sup>3</sup>	Kg						
		0,240	38,5	P.   D. 480	SL1BT4434	593	657	743	781
		0,285	42	P.   D. 576	SL1BT4534	627	694	787	823
				Maniglia Slim   Slim handle		28	28	28	28
				Maniglia gola   Groove handle		140	140	140	140
Elemento con 4 cassetti Element with 4 drawers									
		VOL.m <sup>3</sup>	Kg						
		0,354	50,5	P.   D. 480	SL1BT4454	731	804	911	957
		0,419	58	P.   D. 576	SL1BT4554	769	848	965	1.008
				Maniglia Slim   Slim handle		32	32	32	32
				Maniglia gola   Groove handle		156	156	156	156
Elemento con 8 cassetti - frontale unico Element with 8 drawers - single front									
		VOL.m <sup>3</sup>	Kg						
		0,467	78,5	P.   D. 480	SL1BT4464	1.095	1.172	1.328	1.389
		0,553	89	P.   D. 576	SL1BT4564	1.144	1.231	1.395	1.459
				Maniglia Slim   Slim handle		48	48	48	48
				Maniglia gola   Groove handle		172	172	172	172
Elemento con 8 cassetti Element with 8 drawers									
		VOL.m <sup>3</sup>	Kg						
		0,467	78,5	P.   D. 480	SL1BT8464	1.075	1.172	1.332	1.397
		0,553	89	P.   D. 576	SL1BT8564	1.132	1.235	1.407	1.467
				Maniglia Slim   Slim handle		56	56	56	56
				Maniglia gola   Groove handle		280	280	280	280

Ulteriori combinazioni di aperture e finiture sono possibili utilizzando le scocche vuote a pag. | Additional finishes and opening combinations are possible using the empty bodies on page 67

N.B: L'interno del mobile e del vano a giorno è in materico abbinato per il rovere termotrattato e nodi, in laccato opaco in tinta per i laccati, le superfici UP e per le essenze rovere gesso, visone, cenere e castoro

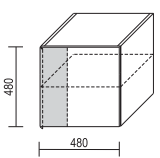
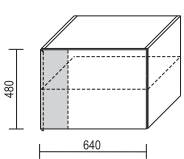
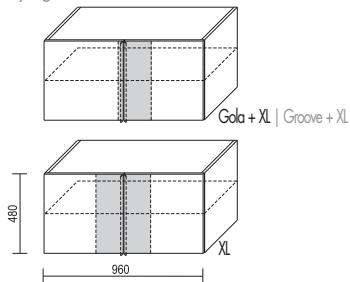
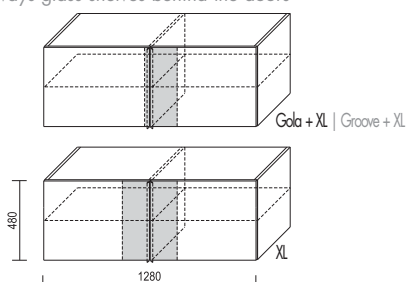
- Aggiungere sempre il top agli elementi a pag.   Always add the top to the elements on page 72 - Apertura standard "push and pull"   Standard 'push and pull' opening		codice code	lacc. opaco matt lacq.	essenza cat. 1 wood cat. 1	essenza cat. 2 wood cat. 2	rovere lacc. matt lacq. oak	lacc. lucido glossy lacq.	superfici UP UP surface		
<p>Elemento con 1 anta specificare nell'ordine se apertura dx o sx, sempre ripiano vetro dietro l'anta Element with 1 door in the order, specify if the opening is rh or lh, always glass shelf behind the door</p> 		VOLm³ Kg	0,157 21	P.   D. 480	SL1SBL423	<b>294</b>	<b>329</b>	<b>361</b>	<b>377</b>	<b>357</b>
				0,185 25	P.   D. 576	SL1SBL523	<b>318</b>	<b>354</b>	<b>388</b>	<b>405</b>
				Maniglia Slim   Slim handle		10	10	10	10	10
				Maniglia gola   Groove handle		37	37	37	37	37
				Maniglia XL   XL handle		38	38	38	38	38
<p>Elemento con 1 anta specificare nell'ordine se apertura dx o sx, sempre ripiano vetro dietro l'anta Element with 1 door in the order, specify if the opening is rh or lh, always glass shelf behind the door</p> 		VOLm³ Kg	0,204 26	P.   D. 480	SL1SBL433	<b>324</b>	<b>360</b>	<b>394</b>	<b>412</b>	<b>393</b>
				0,241 30	P.   D. 576	SL1SBL533	<b>349</b>	<b>388</b>	<b>428</b>	<b>446</b>
				Maniglia Slim   Slim handle		10	10	10	10	10
				Maniglia gola   Groove handle		37	37	37	37	37
				Maniglia XL   XL handle		38	38	38	38	38
<p>Elemento con 2 ante sempre ripiano vetro dietro le ante Element with 2 doors always glass shelf behind the doors</p> 		VOLm³ Kg	0,297 37	P.   D. 480	SL1SBL453	<b>446</b>	<b>494</b>	<b>543</b>	<b>567</b>	<b>532</b>
				0,351 42	P.   D. 576	SL1SBL553	<b>480</b>	<b>531</b>	<b>584</b>	<b>609</b>
				Maniglia Slim   Slim handle		20	20	20	20	20
				Maniglia gola   Groove handle		74	74	74	74	74
				Maniglia XL   XL handle		76	76	76	76	76
				Gola + XL   Groove + XL		75	75	75	75	75
<p>Elemento con 2 ante sempre ripiani vetro dietro le ante Element with 2 doors always glass shelves behind the doors</p> 		VOLm³ Kg	0,377 50	P.   D. 480	SL1SBL463	<b>547</b>	<b>588</b>	<b>649</b>	<b>677</b>	<b>647</b>
				0,446 58	P.   D. 576	SL1SBL563	<b>585</b>	<b>635</b>	<b>699</b>	<b>728</b>
				Maniglia Slim   Slim handle		20	20	20	20	20
				Maniglia gola   Groove handle		74	74	74	74	74
				Maniglia XL   XL handle		76	76	76	76	76
				Gola + XL   Groove + XL		75	75	75	75	75

Ulteriori combinazioni di aperture e finiture sono possibili utilizzando le scocche vuote a pag. | Additional finishes and opening combinations are possible using the empty bodies on page 67

N.B: The interior of the cabinet and open compartment has matching textured f. for heat-treated oak and oak knots finishes and matching matte lacquer for lacquers, UP surfaces, in addition to oak gesso, oak visone, oak cenere and oak castoro woods.

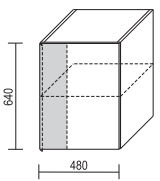
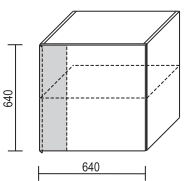
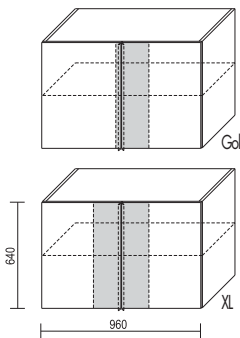
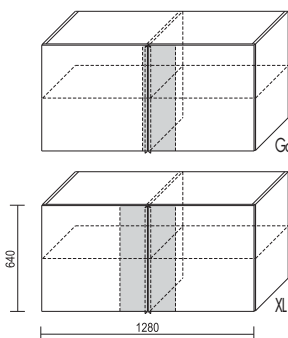
- Aggiungere sempre il top agli elementi a pag.   Always add the top for to elements on page 72 - Apertura standard "push and pull"   Standard 'push and pull' opening		codice code	lacc. opaco matt lacq.	essenza cat. 1 wood cat. 1	essenza cat. 2 wood cat. 2	rovere lacc. matt lacq. oak	lacc. lucido glossy lacq.	superfici UP surface	
<p>Elemento con 1 anta specificare nell'ordine se apertura dx o sx, sempre ripiano vetro dietro l'anta Element with 1 door in the order, specify if the opening is rh or lh, always glass shelf behind the door</p> 									
VOLm³ Kg									
0,184 23,5		P.   D. 480	SL1SBL424	<b>320</b>	<b>360</b>	<b>398</b>	<b>418</b>	<b>392</b>	
0,218 26		P.   D. 576	SL1SBL524	<b>343</b>	<b>387</b>	<b>426</b>	<b>448</b>	<b>425</b>	
		Maniglia Slim   Slim handle		11	11	11	11	11	
		Maniglia gola   Groove handle		39	39	39	39	39	
		Maniglia XL   XL handle		44	44	44	44	44	
<p>Elemento con 1 anta specificare nell'ordine se apertura dx o sx, sempre ripiano vetro dietro l'anta Element with 1 door in the order, specify if the opening is rh or lh, always glass shelf behind the door</p> 									
VOLm³ Kg									
0,240 27,5		P.   D. 480	SL1SBL434	<b>354</b>	<b>396</b>	<b>439</b>	<b>461</b>	<b>436</b>	
0,285 32,5		P.   D. 576	SL1SBL534	<b>382</b>	<b>429</b>	<b>473</b>	<b>497</b>	<b>471</b>	
		Maniglia Slim   Slim handle		11	11	11	11	11	
		Maniglia gola   Groove handle		39	39	39	39	39	
		Maniglia XL   XL handle		44	44	44	44	44	
<p>Elemento con 2 ante, sempre ripiano vetro dietro le ante Element with 2 doors, always glass shelf behind the doors</p> 									
VOLm³ Kg									
0,354 38		P.   D. 480	SL1SBL454	<b>483</b>	<b>540</b>	<b>599</b>	<b>629</b>	<b>587</b>	
0,419 44		P.   D. 576	SL1SBL554	<b>518</b>	<b>582</b>	<b>643</b>	<b>675</b>	<b>633</b>	
		Maniglia Slim   Slim handle		22	22	22	22	22	
		Maniglia gola   Groove handle		78	78	78	78	78	
		Maniglia XL   XL handle		88	88	88	88	88	
		Gola + XL   Groove + XL		83	83	83	83	83	
<p>Elemento con 2 ante, sempre ripiani vetro dietro le ante Element with 2 doors, always glass shelves behind the doors</p> 									
VOLm³ Kg									
0,467 56,5		P.   D. 480	SL1SBL464	<b>598</b>	<b>653</b>	<b>724</b>	<b>758</b>	<b>719</b>	
0,553 64		P.   D. 576	SL1SBL564	<b>640</b>	<b>702</b>	<b>778</b>	<b>814</b>	<b>774</b>	
		Maniglia Slim   Slim handle		22	22	22	22	22	
		Maniglia gola   Groove handle		78	78	78	78	78	
		Maniglia XL   XL handle		88	88	88	88	88	
		Gola + XL   Groove + XL		83	83	83	83	83	

Ulteriori combinazioni di aperture e finiture sono possibili utilizzando le scocche vuote a pag. | Additional finishes and opening combinations are possible using the empty bodies on page 67

N.B: L'interno del mobile e del vano a giorno è in materico abbinato per il rovere termotrattato e nodi, in laccato opaco in tinta per i laccati, le superfici UP e per le essenze rovere gesso, visone, cenere e castoro

- Aggiungere sempre il top agli elementi a pag. | Always add the top to the elements on page 72  
 - Solo apertura "push and pull" | Only "Push and pull" opening

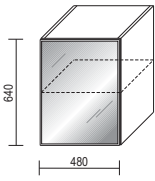
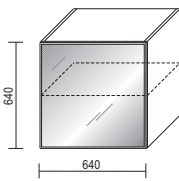
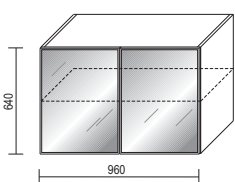
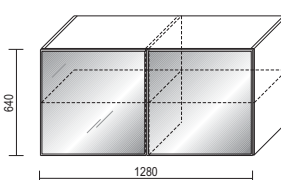
		codice code	lacc. opaco matt lacq.	essenza cat. 1 wood cat. 1	essenza cat. 2 wood cat. 2	rovere lacc. matt lacq. oak	lacc. lucido glossy lacq.	superfici UP UP surface
Elemento con 1 anta vetro SLIM specificare nell'ordine se apertura dx o sx, sempre ripiano vetro dietro l'anta Element with 1 SLIM glass door in the order, specify if the opening is rh or lh, always glass shelf behind the door								
	VOLm³ Kg							
	0,184 24,5	P.   D. 480 vetro   glass (cat 1)	SL1SBV424	<b>438</b>	<b>451</b>	<b>473</b>	<b>483</b>	<b>480</b>
		P.   D. 480 vetro   glass (cat 2)	SL1SBV424	<b>473</b>	<b>486</b>	<b>508</b>	<b>518</b>	<b>515</b>
	0,218 27	P.   D. 576 vetro   glass (cat 1)	SL1SBV524	<b>461</b>	<b>478</b>	<b>501</b>	<b>513</b>	<b>513</b>
	P.   D. 576 vetro   glass (cat 2)	SL1SBV524	<b>496</b>	<b>513</b>	<b>536</b>	<b>548</b>	<b>548</b>	
Elemento con 1 anta vetro SLIM specificare nell'ordine se apertura dx o sx, sempre ripiano vetro dietro l'anta Element with 1 SLIM glass door in the order, specify if the opening is rh or lh, always glass shelf behind the door								
	VOLm³ Kg							
	0,240 28,5	P.   D. 480 vetro   glass (cat 1)	SL1SBV434	<b>488</b>	<b>496</b>	<b>519</b>	<b>529</b>	<b>531</b>
		P.   D. 480 vetro   glass (cat 2)	SL1SBV434	<b>534</b>	<b>542</b>	<b>565</b>	<b>575</b>	<b>577</b>
	0,285 33,5	P.   D. 576 vetro   glass (cat 1)	SL1SBV534	<b>516</b>	<b>529</b>	<b>553</b>	<b>565</b>	<b>566</b>
	P.   D. 576 vetro   glass (cat 2)	SL1SBV534	<b>562</b>	<b>575</b>	<b>599</b>	<b>611</b>	<b>612</b>	
Elemento con 2 ante vetro SLIM sempre ripiano vetro dietro le ante Element with 2 SLIM glass doors always glass shelf behind the doors								
	VOLm³ Kg							
	0,354 39	P.   D. 480 vetro   glass (cat 1)	SL1SBV454	<b>719</b>	<b>722</b>	<b>749</b>	<b>759</b>	<b>763</b>
		P.   D. 480 vetro   glass (cat 2)	SL1SBV454	<b>789</b>	<b>792</b>	<b>819</b>	<b>829</b>	<b>833</b>
	0,419 46	P.   D. 576 vetro   glass (cat 1)	SL1SBV554	<b>754</b>	<b>764</b>	<b>793</b>	<b>805</b>	<b>809</b>
	P.   D. 576 vetro   glass (cat 2)	SL1SBV554	<b>824</b>	<b>834</b>	<b>863</b>	<b>875</b>	<b>879</b>	
Elemento con 2 ante vetro SLIM sempre ripiani vetro dietro le ante Element with 2 SLIM glass doors always glass shelves behind the doors								
	VOLm³ Kg							
	0,467 58,5	P.   D. 480 vetro   glass (cat 1)	SL1SBV464	<b>866</b>	<b>853</b>	<b>884</b>	<b>894</b>	<b>909</b>
		P.   D. 480 vetro   glass (cat 2)	SL1SBV464	<b>958</b>	<b>945</b>	<b>976</b>	<b>986</b>	<b>1.001</b>
	0,553 66	P.   D. 576 vetro   glass (cat 1)	SL1SBV564	<b>908</b>	<b>902</b>	<b>938</b>	<b>950</b>	<b>964</b>
	P.   D. 576 vetro   glass (cat 2)	SL1SBV564	<b>1.000</b>	<b>994</b>	<b>1.030</b>	<b>1.042</b>	<b>1.056</b>	

Ulteriori combinazioni di aperture e finiture sono possibili utilizzando le scocche vuote a pag. | Additional finishes and opening combinations are possible using the empty bodies on page 67

N.B: The interior of the cabinet and open compartment has matching textured f. for heat-treated oak and oak knots finishes and matching matte lacquer for lacquers, UP surfaces, in addition to oak gesso, oak visone, oak cenere and oak castoro woods.

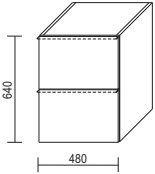
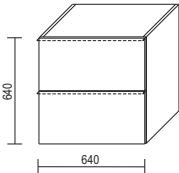
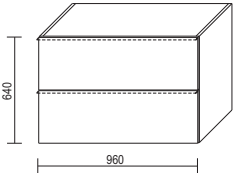
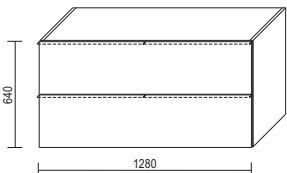
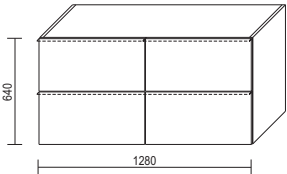
- Aggiungere sempre il top agli elementi a pag.   Always add the top to the elements on page 72 - Apertura standard "push and pull"   Standard 'push and pull' opening - Non è possibile l'abbinamento di cassetti con maniglia insieme a cassetti apertura "push and pull" Drawers with handles cannot be combined with "push and pull"-opening drawers		codice	lacc. opaco	essenza cat. 1	essenza cat. 2	rovere lacc.	lacc. lucido	
		code	matt lacq.	wood cat. 1	wood cat. 2	matt lacq. oak	glossy lacq.	
							superfici UP UP surface	
Elemento con 2 cestoni Element with 2 deep drawers								
	VOL.m <sup>3</sup> Kg							
	0,184 29	P.   D. 480	SL1SC2424	<b>402</b>	<b>445</b>	<b>501</b>	<b>523</b>	<b>476</b>
	0,218 32,5	P.   D. 576	SL1SC2524	<b>429</b>	<b>482</b>	<b>539</b>	<b>561</b>	<b>511</b>
		Maniglia Slim   Slim handle Maniglia gola   Groove handle		12 64	12 64	12 64	12 64	12 64
Elemento con 2 cestoni Element with 2 deep drawers								
	VOL.m <sup>3</sup> Kg							
	0,240 33	P.   D. 480	SL1SC2434	<b>456</b>	<b>506</b>	<b>567</b>	<b>591</b>	<b>537</b>
	0,285 38,5	P.   D. 576	SL1SC2534	<b>485</b>	<b>544</b>	<b>612</b>	<b>636</b>	<b>577</b>
		Maniglia Slim   Slim handle Maniglia gola   Groove handle		14 70	14 70	14 70	14 70	14 70
Elemento con 2 cestoni Element with 2 deep drawers								
	VOL.m <sup>3</sup> Kg							
	0,354 42,5	P.   D. 480	SL1SC2454	<b>566</b>	<b>627</b>	<b>712</b>	<b>742</b>	<b>664</b>
	0,419 50	P.   D. 576	SL1SC2554	<b>604</b>	<b>680</b>	<b>767</b>	<b>799</b>	<b>713</b>
		Maniglia Slim   Slim handle Maniglia gola   Groove handle		16 78	16 78	16 78	16 78	16 78
Elemento con 4 cestoni - frontale unico Element with 4 deep drawers - single front								
	VOL.m <sup>3</sup> Kg							
	0,467 67,5	P.   D. 480	SL1SC2464	<b>794</b>	<b>855</b>	<b>962</b>	<b>1.004</b>	<b>907</b>
	0,553 76	P.   D. 576	SL1SC2564	<b>842</b>	<b>916</b>	<b>1.034</b>	<b>1.072</b>	<b>972</b>
		Maniglia Slim   Slim handle Maniglia gola   Groove handle		24 86	24 86	24 86	24 86	24 86
Elemento con 4 cestoni Element with 4 deep drawers								
	VOL.m <sup>3</sup> Kg							
	0,467 67,5	P.   D. 480	SL1SC4464	<b>802</b>	<b>873</b>	<b>980</b>	<b>1.018</b>	<b>921</b>
	0,553 76	P.   D. 576	SL1SC4564	<b>846</b>	<b>932</b>	<b>1.056</b>	<b>1.092</b>	<b>986</b>
		Maniglia Slim   Slim handle Maniglia gola   Groove handle		28 140	28 140	28 140	28 140	28 140

Ulteriori combinazioni di aperture e finiture sono possibili utilizzando le scocche vuote a pag. | Additional finishes and opening combinations are possible using the empty bodies on page 67



## ESEMPI DI COMBINAZIONI | EXAMPLE OF COMBINATIONS

N.B: The interior of the cabinet and open compartment has matching textured f. for heat-treated oak and oak knots finishes and matching matte lacquer for lacquers, UP surfaces, in addition to oak gesso, oak visone, oak cenere and oak castoro woods.

- Non è possibile l'abbinamento di cassetti con maniglia insieme a cassetti apertura "push and pull".
- L'interno del mobile e del vano a giorno è in materico abbinato per il rovere termotrattato e nodi, in laccato opaco in tinta per i laccati, le superfici UP e per le essenze rovere gesso, visone, cenere e castoro.
- Drawers with handles cannot be combined with "push and pull"-opening drawers.
- The interior of the cabinet and open compartment has a matching textured finish for heat-treated oak and oak knots finishes and matching matte lacquer for lacquers, UP surfaces, in addition to oak gesso, oak visone, oak cenere and oak castoro woods.

### ESEMPIO DI COMBINAZIONI PER BASI | EXAMPLE OF BASE UNIT COMBINATIONS

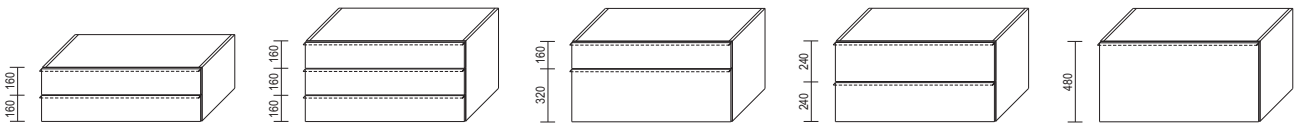

Per suddividere il vano in altezza tra una ribalta e altri frontali (ribalta, cassetto/cestone, vano a giorno) o tra un cassetto/cestone e vano a giorno, si deve necessariamente impiegare il divisorio legno sp. 40, vedi esempio a lato.

In order to divide the compartment in height, it's necessary to use a wooden partition th. 40 between a flap door and other fronts (flap, drawer/deep drawer, open compartment), or between a drawer/deep drawer and an open compartment. Check the example on the right.

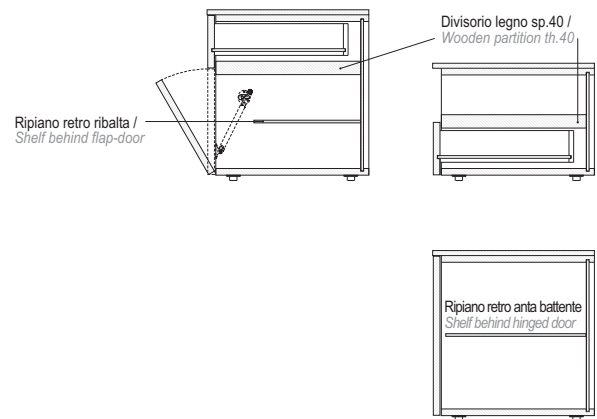

### ESEMPIO DI COMBINAZIONI PER ELEMENTI | EXAMPLE OF ELEMENT COMBINATIONS

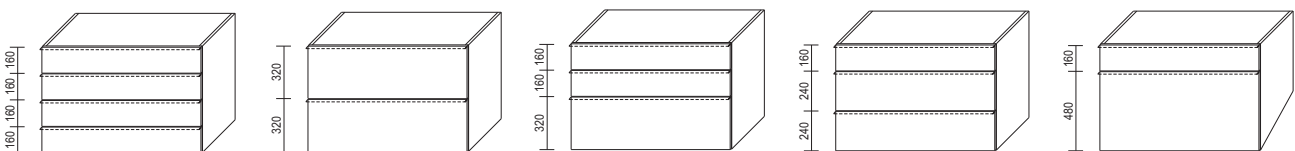



N.B: L'interno del mobile e del vano a giorno è in materico abbinato per il rovere termotrattato e nodi, in laccato opaco in tinta per i laccati, le superfici UP e per le essenze rovere gesso, visone, cenere e castoro

Il prezzo totale è dato dalla somma della SCocca vuota (1) + FRONTALI (2) + EV. RIPIANO O DIVISORIO (3)

The total price is given by the sum of the EMPTY BODY (1) + FRONTS (2) + ANY SHELF OR PARTITION (3)

- Aggiungere sempre il top alle basi a pag. | Always add the top to the bases on page 72

			codice code	lacc. opaco matt lacq.	essenza cat. 1 wood cat. 1	essenza cat. 2 wood cat. 2	rovere lacc. matt lacq. oak	lacc. lucido glossy lacq.	superfici UP UP surface				
SCOCHE VUOTE   EMPTY BODIES	(1)	Scocca vuota base 1 vano Empty body for base with 1 compartment	Basi terra / appoggio Free-standing / supported	P.   D. 480	L. 480	SL1B01420	146	162	173	177	157		
					L. 640	SL1B01430	160	177	187	191	174		
					L. 960	SL1B01450	209	219	231	234	223		
					P.   D. 576	L. 480	SL1B01520	156	174	187	192	172	
						L. 640	SL1B01530	175	189	202	207	189	
						L. 960	SL1B01550	224	234	247	251	241	
		Basi sospese Suspended	P.   D. 480	L. 480	SL1B11420	155	170	181	185	167			
				L. 640	SL1B11430	172	188	199	203	186			
				L. 960	SL1B11450	226	237	248	251	241			
				P.   D. 576	L. 480	SL1B11520	167	186	199	204	183		
					L. 640	SL1B11530	189	204	216	221	203		
					L. 960	SL1B11550	243	255	266	270	262		
		Scocca vuota base 2 vani Empty body for base with 2 compartments	Basi terra / appoggio Free-standing / supported	P.   D. 480	SL1B02460	252	259	269	273	267			
					SL1B02560	272	269	281	286	285			
					Basi sospese Suspended	P.   D. 480	SL1B12460	273	281	291	295	288	
							SL1B12560	301	298	310	315	313	
							Scocca vuota base 2 vani Empty body for base with 2 compartments	Basi terra / appoggio Free-standing / supported	P.   D. 480	SL1B02470	313	313	323
					SL1B02570	341				337	350	355	354
Basi sospese Suspended	P.   D. 480	SL1B12470	351	350	362	366				364			
		SL1B12570	385	379	394	399				397			
		Scocca vuota base 2 vani Empty body for base with 2 compartments	Basi terra / appoggio Free-standing / supported	P.   D. 480	SL1B02480	346				345	356	359	361
SL1B02580	376				369	382				386	393		
Basi sospese Suspended	P.   D. 480				SL1B12480	387	385	397	400	402			
					SL1B12580	424	415	430	434	441			
					Scocca vuota base 3 vani Empty body for base with 3 compartments	Basi terra / appoggio Free-standing / supported	P.   D. 480	SL1B03480	366	366	376	380	381
SL1B03580	399							390	403	408	415		
Basi sospese Suspended	P.   D. 480	SL1B13480	407	406				417	421	422			
		SL1B13580	445	436				451	456	463			

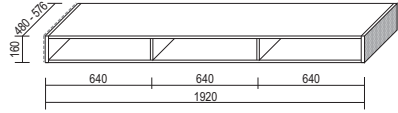
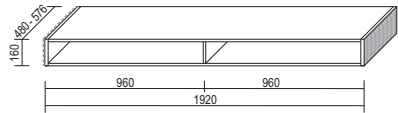
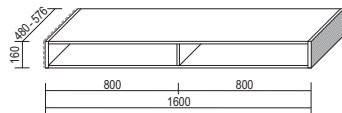
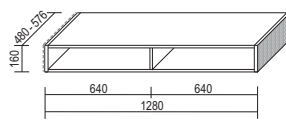
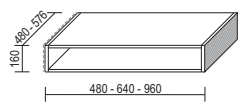

N.B: The interior of the cabinet and open compartment has matching textured f. for heat-treated oak and oak knots finishes and matching matte lacquer for lacquers, UP surfaces, in addition to oak gesso, oak visone, oak cenere and oak castoro woods.

Il prezzo totale è dato dalla somma della SCOCCHA VUOTA (1) + FRONTALI (2) + EV. RIPIANO O DIVISORIO (3)  
 The total price is given by the sum of the EMPTY BODY (1) + FRONTS (2) + ANY SHELF OR PARTITION (3)  
 - Aggiungere sempre il top alle basi a pag. | Always add the top to the bases on page 72

codice code	lacc. opaco matt lacq.	essenza cat. 1 wood cat. 1	essenza cat. 2 wood cat. 2	rovere lacc. matt lacq. oak	lacc. lucido glossy lacq.	superfici UP UP surface
-------------	------------------------	----------------------------	----------------------------	-----------------------------	---------------------------	-------------------------

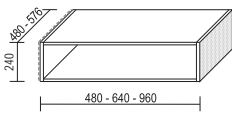
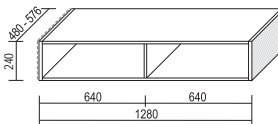
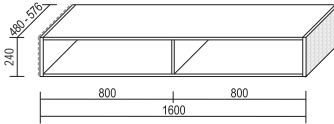
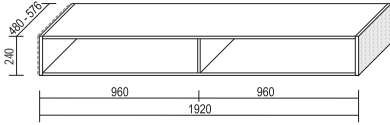
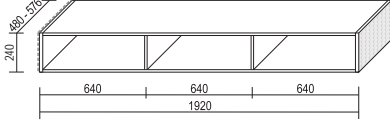
SCOCHE VUOTE   EMPTY BODIES	<p>(1) Scocca vuota base 1 vano Empty body for base with 1 compartment</p> <p>Basi terra / appoggio Freestanding / supported</p> 	P.   D. 480							
		L. 480	SL1B01421	157	182	198	202	173	
		L. 640	SL1B01431	174	199	214	218	192	
		L. 960	SL1B01451	222	240	256	261	238	
		P.   D. 576							
		L. 480	SL1B01521	169	195	212	216	191	
		L. 640	SL1B01531	189	212	229	235	209	
		L. 960	SL1B01551	240	252	270	275	260	
		Basi sospese Suspended	P.   D. 480						
		L. 480	SL1B11421	166	189	206	210	183	
		L. 640	SL1B11431	186	210	226	229	204	
		L. 960	SL1B11451	239	259	274	278	256	
	P.   D. 576								
	L. 480	SL1B11521	180	207	224	228	201		
	L. 640	SL1B11531	204	227	243	249	223		
	L. 960	SL1B11551	260	273	290	294	280		
	Scocca vuota base 2 vani Empty body for base with 2 compartments	Basi terra / appoggio Free-standing / supported	P.   D. 480	SL1B02461	270	278	294	297	290
		P.   D. 576	SL1B02561	290	291	308	314	309	
	Basi sospese Suspended	P.   D. 480	SL1B12461	291	300	316	319	310	
	P.   D. 576	SL1B12561	319	320	337	343	337		
	Scocca vuota base 2 vani Empty body for base with 2 compartments	Basi terra / appoggio Free-standing / supported	P.   D. 480	SL1B02471	332	335	351	355	351
		P.   D. 576	SL1B02571	362	361	378	383	383	
	Basi sospese Suspended	P.   D. 480	SL1B12471	370	372	390	394	389	
	P.   D. 576	SL1B12571	407	403	423	427	426		
Scocca vuota base 2 vani Empty body for base with 2 compartments	Basi terra / appoggio Free-standing / supported	P.   D. 480	SL1B02481	368	366	382	386	387	
	P.   D. 576	SL1B02581	399	390	408	413	421		
Basi sospese Suspended	P.   D. 480	SL1B12481	409	405	423	427	428		
P.   D. 576	SL1B12581	447	437	455	461	468			
Scocca vuota base 3 vani Empty body for base with 3 compartments	Basi terra / appoggio Free-standing / supported	P.   D. 480	SL1B03481	390	387	403	407	411	
	P.   D. 576	SL1B03581	426	413	430	435	447		
Basi sospese Suspended	P.   D. 480	SL1B13481	431	427	444	448	452		
P.   D. 576	SL1B13581	472	459	478	482	494			

N.B: L'interno del mobile e del vano a giorno è in materico abbinato per il rovere termotrattato e nodi, in laccato opaco in tinta per i laccati, le superfici UP e per le essenze rovere gesso, visone, cenere e castoro

Il prezzo totale è dato dalla somma della SCOCCHA VUOTA (1) + FRONTALI (2) + EV. RIPIANO O DIVISORIO (3)  
 The total price is given by the sum of the EMPTY BODY (1) + FRONTS (2) + ANY SHELF OR PARTITION (3)  
 - Aggiungere sempre il top alle basi a pag. | Always add the top to the bases on page 72

codice code	lacc. opaco matt lacq.	essenza cat. 1 wood cat. 1	essenza cat. 2 wood cat. 2	rovere lacc. matt lacq. oak	lacc. lucido glossy lacq.	superfici UP UP surface
-------------	------------------------	----------------------------	----------------------------	-----------------------------	---------------------------	-------------------------

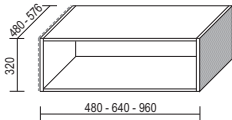
<p>(1) Scocca vuota base 1 vano Empty body for base with 1 compartment</p> <p>Basi terra / appoggio Free-standing / supported</p> 	P.   D. 480						
	L. 480	SL1B01422	168	188	211	216	189
	L. 640	SL1B01432	188	207	227	233	209
	L. 960	SL1B01452	235	242	266	272	253
	P.   D. 576						
	L. 480	SL1B01522	182	207	228	235	208
	L. 640	SL1B01532	204	225	247	253	228
	L. 960	SL1B01552	255	261	282	289	277
	Basi sospese Suspended	P.   D. 480					
	L. 480	SL1B11422	177	197	218	223	199
	L. 640	SL1B11432	200	219	239	245	221

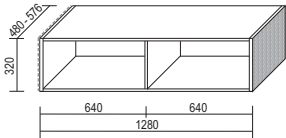
<p>Scocca vuota base 2 vani Empty body for base with 2 compartments</p> 	Basi terra / appoggio Free-standing / supported							
	P.   D. 480	SL1B02462	289	279	301	306	313	
	P.   D. 576	SL1B02562	307	302	323	330	333	
	Basi sospese Suspended	P.   D. 480	SL1B12462	309	300	322	328	333
	P.   D. 576	SL1B12562	336	329	351	358	361	

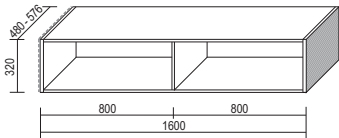
<p>Scocca vuota base 2 vani Empty body for base with 2 compartments</p> 	Basi terra / appoggio Free-standing / supported							
	P.   D. 480	SL1B02472	351	337	359	364	376	
	P.   D. 576	SL1B02572	384	372	393	399	411	
	Basi sospese Suspended	P.   D. 480	SL1B12472	389	373	396	401	414
	P.   D. 576	SL1B12572	428	412	434	440	454	

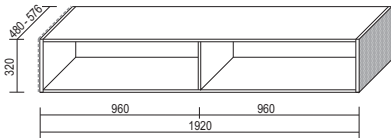
<p>Scocca vuota base 2 vani Empty body for base with 2 compartments</p> 	Basi terra / appoggio Free-standing / supported							
	P.   D. 480	SL1B02482	388	362	384	389	413	
	P.   D. 576	SL1B02582	422	398	421	427	449	
	Basi sospese Suspended	P.   D. 480	SL1B12482	429	404	425	430	454
	P.   D. 576	SL1B12582	469	442	464	470	496	

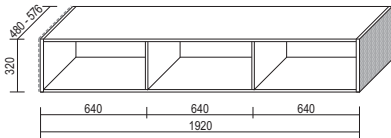
<p>Scocca vuota base 3 vani Empty body for base with 3 compartments</p> 	Basi terra / appoggio Free-standing / supported							
	P.   D. 480	SL1B03482	415	384	407	412	440	
	P.   D. 576	SL1B03582	452	422	442	449	478	
	Basi sospese Suspended	P.   D. 480	SL1B13482	456	425	444	450	481
	P.   D. 576	SL1B13582	498	465	488	494	525	

N.B: The interior of the cabinet and open compartment has matching textured f. for heat-treated oak and oak knots finishes and matching matte lacquer for lacquers, UP surfaces, in addition to oak gesso, oak visone, oak cenere and oak castoro woods.

Il prezzo totale è dato dalla somma della SCOCCHA VUOTA (1) + FRONTALI (2) + EV. RIPIANO O DIVISORIO (3)  
 The total price is given by the sum of the EMPTY BODY (1) + FRONTS (2) + ANY SHELF OR PARTITION (3)  
 - Aggiungere sempre il top alle basi a pag. | Always add the top to the bases on page 72

codice code	lacc. opaco matt lacq.	essenza cat. 1 wood cat. 1	essenza cat. 2 wood cat. 2	rovere lacc. matt lacq. oak	lacc. lucido glossy lacq.	superfici UP UP surface
-------------	------------------------	----------------------------	----------------------------	-----------------------------	---------------------------	-------------------------

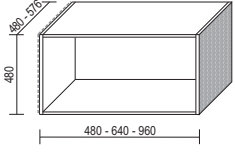
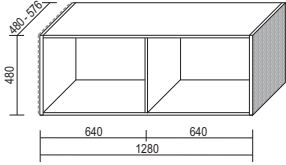
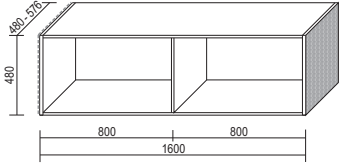
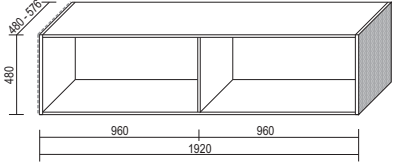
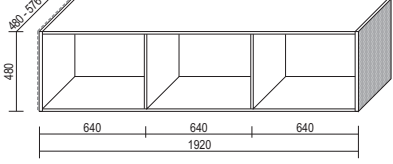
SCOCHE VUOTE   EMPTY BODIES	<p>(1) Scocca vuota base 1 vano Empty body for base with 1 compartment</p> <p>Basi terra / appoggio Freestanding / supported</p> 	P.   D. 480							
		L. 480	SL1B01423	201	214	235	242	241	
		L. 640	SL1B01433	218	226	247	254	256	
		L. 960	SL1B01453	267	270	295	303	306	
		P.   D. 576							
		L. 480	SL1B01523	221	236	256	265	268	
		L. 640	SL1B01533	237	249	273	281	286	
		L. 960	SL1B01553	291	301	326	334	342	
		Basi sospese Suspended	P.   D. 480						
		L. 480	SL1B11423	209	222	241	249	249	
		L. 640	SL1B11433	229	238	256	264	268	
		L. 960	SL1B11453	283	287	310	318	323	
	P.   D. 576								
	L. 480	SL1B11523	231	245	266	275	277		
	L. 640	SL1B11533	251	263	287	295	299		
	L. 960	SL1B11553	312	319	346	355	361		
	Scocca vuota base 2 vani Empty body for base with 2 compartments	Basi terra / appoggio Freestanding / supported	P.   D. 480	SL1B02463	334	323	353	360	374
		P.   D. 576	SL1B02563	362	359	391	400	414	
	Basi sospese Suspended	P.   D. 480	SL1B12463	357	344	373	381	397	
	P.   D. 576	SL1B12563	389	385	417	426	441		
	Scocca vuota base 2 vani Empty body for base with 2 compartments	Basi terra / appoggio Freestanding / supported	P.   D. 480	SL1B02473	410	389	418	426	439
		P.   D. 576	SL1B02573	448	426	457	466	479	
	Basi sospese Suspended	P.   D. 480	SL1B12473	454	429	457	465	483	
	P.   D. 576	SL1B12573	499	471	504	512	530		
Scocca vuota base 2 vani Empty body for base with 2 compartments	Basi terra / appoggio Freestanding / supported	P.   D. 480	SL1B02483	453	418	447	454	482	
	P.   D. 576	SL1B02583	492	454	484	493	523		
Basi sospese Suspended	P.   D. 480	SL1B12483	501	461	502	509	530		
P.   D. 576	SL1B12583	547	506	536	545	578			
Scocca vuota base 3 vani Empty body for base with 3 compartments	Basi terra / appoggio Freestanding / supported	P.   D. 480	SL1B03483	484	447	476	483	513	
	P.   D. 576	SL1B03583	526	484	516	524	557		
Basi sospese Suspended	P.   D. 480	SL1B13483	532	490	519	526	561		
P.   D. 576	SL1B13583	582	536	569	577	613			

N.B: L'interno del mobile e del vano a giorno è in materico abbinato per il rovere termotrattato e nodi, in laccato opaco in tinta per i laccati, le superfici UP e per le essenze rovere gesso, visone, cenere e castoro

Il prezzo totale è dato dalla somma della SCocca vuota (1) + FRONTALI (2) + EV. RIPIANO O DIVISORIO (3)  
 The total price is given by the sum of the EMPTY BODY (1) + FRONTS (2) + ANY SHELF OR PARTITION (3)  
 - Aggiungere sempre il top alle basi a pag. | Always add the top to the bases on page 72

codice code	lacc. opaco matt lacq.	essenza cat. 1 wood cat. 1	essenza cat. 2 wood cat. 2	rovere lacc. matt lacq. oak	lacc. lucido glossy lacq.	maniglia Slim	maniglia gola Groove handle				
					superfici UP UP surface						
<b>(2) Cassetto H. 160</b> Drawer H. 160		VOLm <sup>3</sup> Kg	P.   D. 480								
		0,047 3,8	L. 480	SL1C20421	<b>77</b>	<b>87</b>	<b>99</b>	<b>104</b>	<b>84</b>	<b>6</b>	<b>32</b>
		0,061 4,7	L. 640	SL1C20431	<b>89</b>	<b>103</b>	<b>119</b>	<b>126</b>	<b>100</b>	<b>7</b>	<b>35</b>
		0,076 5,5	L. 800	SL1C20441	<b>103</b>	<b>119</b>	<b>138</b>	<b>146</b>	<b>114</b>	<b>7</b>	<b>37</b>
		0,090 6,5	L. 960	SL1C20451	<b>110</b>	<b>128</b>	<b>148</b>	<b>157</b>	<b>126</b>	<b>8</b>	<b>39</b>
		0,119 8,8	L. 1280	SL1C20461	<b>183</b>	<b>206</b>	<b>237</b>	<b>250</b>	<b>201</b>	<b>12</b>	<b>43</b>
			P.   D. 576								
		0,057 4,3	L. 480	SL1C20521	<b>79</b>	<b>89</b>	<b>102</b>	<b>107</b>	<b>86</b>	<b>6</b>	<b>32</b>
		0,075 5,2	L. 640	SL1C20531	<b>92</b>	<b>106</b>	<b>123</b>	<b>129</b>	<b>102</b>	<b>7</b>	<b>35</b>
		0,092 6,3	L. 800	SL1C20541	<b>106</b>	<b>123</b>	<b>142</b>	<b>151</b>	<b>118</b>	<b>7</b>	<b>37</b>
		0,110 7,4	L. 960	SL1C20551	<b>113</b>	<b>131</b>	<b>153</b>	<b>161</b>	<b>129</b>	<b>8</b>	<b>39</b>
		0,145 10	L. 1280	SL1C20561	<b>187</b>	<b>211</b>	<b>243</b>	<b>256</b>	<b>207</b>	<b>12</b>	<b>43</b>
<b>Cassetto H. 240</b> Drawer H. 240		VOLm <sup>3</sup> Kg	P.   D. 480								
		0,066 4,9	L. 480	SL1C20422	<b>81</b>	<b>100</b>	<b>115</b>	<b>119</b>	<b>93</b>	<b>6</b>	<b>32</b>
		0,086 6,0	L. 640	SL1C20432	<b>97</b>	<b>119</b>	<b>137</b>	<b>142</b>	<b>111</b>	<b>7</b>	<b>35</b>
		0,099 6,8	L. 800	SL1C20442	<b>111</b>	<b>138</b>	<b>161</b>	<b>168</b>	<b>129</b>	<b>7</b>	<b>37</b>
		0,127 8,1	L. 960	SL1C20452	<b>120</b>	<b>151</b>	<b>177</b>	<b>184</b>	<b>141</b>	<b>8</b>	<b>39</b>
		0,168 10,9	L. 1280	SL1C20462	<b>193</b>	<b>234</b>	<b>270</b>	<b>280</b>	<b>220</b>	<b>12</b>	<b>43</b>
			P.   D. 576								
		0,80 5,4	L. 480	SL1C20522	<b>84</b>	<b>102</b>	<b>118</b>	<b>123</b>	<b>96</b>	<b>6</b>	<b>32</b>
		0,105 6,6	L. 640	SL1C20532	<b>99</b>	<b>123</b>	<b>142</b>	<b>147</b>	<b>114</b>	<b>7</b>	<b>35</b>
		0,120 7,5	L. 800	SL1C20542	<b>114</b>	<b>142</b>	<b>164</b>	<b>171</b>	<b>132</b>	<b>7</b>	<b>37</b>
		0,154 8,8	L. 960	SL1C20552	<b>124</b>	<b>155</b>	<b>181</b>	<b>188</b>	<b>144</b>	<b>8</b>	<b>39</b>
		0,204 12,1	L. 1280	SL1C20562	<b>197</b>	<b>239</b>	<b>277</b>	<b>288</b>	<b>225</b>	<b>12</b>	<b>43</b>
<b>Cestone H. 320</b> Deep drawer H. 320		VOLm <sup>3</sup> Kg	P.   D. 480								
		0,085 6,1	L. 480	SL1C20423	<b>87</b>	<b>102</b>	<b>119</b>	<b>125</b>	<b>103</b>	<b>6</b>	<b>32</b>
		0,111 7,5	L. 640	SL1C20433	<b>104</b>	<b>125</b>	<b>144</b>	<b>151</b>	<b>123</b>	<b>7</b>	<b>35</b>
		0,137 8,9	L. 800	SL1C20443	<b>120</b>	<b>145</b>	<b>170</b>	<b>179</b>	<b>143</b>	<b>7</b>	<b>37</b>
		0,163 10,4	L. 960	SL1C20453	<b>130</b>	<b>159</b>	<b>188</b>	<b>198</b>	<b>157</b>	<b>8</b>	<b>39</b>
		0,216 14,6	L. 1280	SL1C20463	<b>204</b>	<b>241</b>	<b>279</b>	<b>295</b>	<b>239</b>	<b>12</b>	<b>43</b>
			P.   D. 576								
		0,103 6,8	L. 480	SL1C20523	<b>90</b>	<b>108</b>	<b>125</b>	<b>130</b>	<b>105</b>	<b>6</b>	<b>32</b>
		0,135 8,4	L. 640	SL1C20533	<b>106</b>	<b>129</b>	<b>151</b>	<b>157</b>	<b>127</b>	<b>7</b>	<b>35</b>
		0,167 9,8	L. 800	SL1C20543	<b>124</b>	<b>151</b>	<b>177</b>	<b>185</b>	<b>147</b>	<b>7</b>	<b>37</b>
		0,199 11,4	L. 960	SL1C20553	<b>134</b>	<b>167</b>	<b>196</b>	<b>206</b>	<b>161</b>	<b>8</b>	<b>39</b>
		0,262 16,1	L. 1280	SL1C20563	<b>210</b>	<b>250</b>	<b>291</b>	<b>304</b>	<b>247</b>	<b>12</b>	<b>43</b>
<b>Cestone H. 480</b> Deep drawer H. 480		VOLm <sup>3</sup> Kg	P.   D. 480								
		0,122 7,4	L. 480	SL1C20424	<b>98</b>	<b>121</b>	<b>146</b>	<b>154</b>	<b>124</b>	<b>6</b>	<b>32</b>
		0,160 9,1	L. 640	SL1C20434	<b>118</b>	<b>145</b>	<b>177</b>	<b>186</b>	<b>146</b>	<b>7</b>	<b>35</b>
		0,184 10,4	L. 800	SL1C20444	<b>134</b>	<b>171</b>	<b>207</b>	<b>219</b>	<b>168</b>	<b>7</b>	<b>37</b>
		0,236 12,5	L. 960	SL1C20454	<b>150</b>	<b>193</b>	<b>234</b>	<b>248</b>	<b>189</b>	<b>8</b>	<b>39</b>
		0,312 17,2	L. 1280	SL1C20464	<b>228</b>	<b>283</b>	<b>339</b>	<b>358</b>	<b>282</b>	<b>12</b>	<b>43</b>
			P.   D. 576								
		0,149 8,1	L. 480	SL1C20524	<b>100</b>	<b>125</b>	<b>152</b>	<b>159</b>	<b>126</b>	<b>6</b>	<b>32</b>
		0,195 9,8	L. 640	SL1C20534	<b>120</b>	<b>152</b>	<b>184</b>	<b>194</b>	<b>151</b>	<b>7</b>	<b>35</b>
		0,224 11,2	L. 800	SL1C20544	<b>138</b>	<b>178</b>	<b>214</b>	<b>226</b>	<b>171</b>	<b>7</b>	<b>37</b>
		0,288 13,4	L. 960	SL1C20554	<b>154</b>	<b>200</b>	<b>243</b>	<b>258</b>	<b>194</b>	<b>8</b>	<b>39</b>
		0,380 18,7	L. 1280	SL1C20564	<b>235</b>	<b>294</b>	<b>353</b>	<b>372</b>	<b>291</b>	<b>12</b>	<b>43</b>

FRONTALI | FRONTS

N.B: The interior of the cabinet and open compartment has matching textured f. for heat-treated oak and oak knots finishes and matching matte lacquer for lacquers, UP surfaces, in addition to oak gesso, oak visone, oak cenere and oak castoro woods.

Il prezzo totale è dato dalla somma della SCOCCHA VUOTA (1) + FRONTALI (2) + EV. RIPIANO O DIVISORIO (3)  
 The total price is given by the sum of the EMPTY BODY (1) + FRONTS (2) + ANY SHELF OR PARTITION (3)  
 - Aggiungere sempre il top alle basi a pag. | Always add the top to the bases on page 72

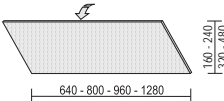
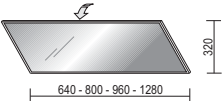
				codice code	lacc. opaco matt lacq.	essenza cat. 1 wood cat. 1	essenza cat. 2 wood cat. 2	rovere lacc. matt lacq. oak	lacc. lucido glossy lacq. superfici UP UP surface	maniglia Slim handle	maniglia gola Groove handle	
FRONTALI   FRONTS	<p>(2) Ribalta legno Wooden flap-door</p> <p>Possibile l'inserimento di braccetti a filo solo con maniglia, maggiorazione a pag. 118 Wire hinges can only be inserted in fronts with handles. Surcharge on page 118</p> 	VOLm³ Kg		H. 160								
		0,006	1,5	L. 640	SL1A22231	75	91	103	107	88	16	39
		0,007	1,8	L. 800	SL1A22241	80	100	115	120	94	18	43
		0,008	2,5	L. 960	SL1A22251	87	107	124	129	101	19	46
		0,010	3	L. 1280	SL1A22261	105	131	148	157	126	30	51
		VOLm³ Kg		H. 240								
		0,011	2	L. 640	SL1A22232	98	126	143	150	116	16	39
		0,014	2,5	L. 800	SL1A22242	105	138	160	167	126	18	43
		0,017	3	L. 960	SL1A22252	113	148	174	183	134	19	46
		0,022	4	L. 1280	SL1A22262	135	180	214	225	166	30	51
		VOLm³ Kg		H. 320								
		0,014	3,2	L. 640	SL1A22233	105	130	150	156	126	16	39
		0,018	3,8	L. 800	SL1A22243	113	142	167	175	137	18	43
		0,021	4,5	L. 960	SL1A22253	121	152	183	193	147	19	46
		0,028	6	L. 1280	SL1A22263	145	185	224	237	180	30	51
		VOLm³ Kg		H. 480								
		0,021	4,5	L. 640	SL1A22234	129	167	195	205	159	16	39
		0,026	5,5	L. 800	SL1A22244	140	183	219	231	175	18	43
		0,031	6,5	L. 960	SL1A22254	151	198	241	255	189	19	46
		0,041	8,5	L. 1280	SL1A22264	187	275	330	349	241	30	51
FRONTALI   FRONTS	<p>Ribalta vetro SLIM SLIM glass flap-door</p> <p>Non è possibile l'inserimento di braccetti a filo Lid supports cannot be inserted</p> 	VOLm³ Kg		vetro   glass (cat 1) vetro   glass (cat 2)								
		0,015	4	L. 640	SL1A23233	207	225					
		0,019	4,5	L. 800	SL1A23243	229	253					
		0,022	5,5	L. 960	SL1A23253	252	283					
		0,029	7	L. 1280	SL1A23263	316	357					

N.B: L'interno del mobile e del vano a giorno è in materico abbinato per il rovere termotrattato e nodi, in laccato opaco in tinta per i laccati, le superfici UP e per le essenze rovere gesso, visone, cenere e castoro

Il prezzo totale è dato dalla somma della SCOCCA VUOTA (1) + FRONTALI (2) + EV. RIPIANO O DIVISORIO (3)  
 The total price is given by the sum of the EMPTY BODY (1) + FRONTS (2) + ANY SHELF OR PARTITION (3)  
 - Aggiungere sempre il top alle basi a pag. | Always add the top to the bases on page 72

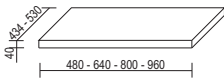
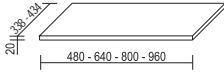
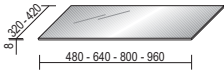
			codice code	lacc. opaco matt lacq.	materico textured finish		
(3)	Divisorio legno sp. 40 Wooden partition th. 40  	Kg	Per base   For base P.   D. 480				
			3	L. 480	SL1R40422	<b>49</b>   <b>35</b>	
			4,5	L. 640	SL1R40432	<b>59</b>   <b>38</b>	
			4	L. 800	SL1R40442	<b>70</b>   <b>47</b>	
		5,5	L. 960	SL1R40452	<b>79</b>   <b>54</b>		
		Kg	Per base   For base P.   D.576				
			4	L. 480	SL1R40522	<b>56</b>   <b>38</b>	
			4,5	L. 640	SL1R40532	<b>65</b>   <b>42</b>	
			5	L. 800	SL1R40542	<b>76</b>   <b>50</b>	
		6,5	L. 960	SL1R40552	<b>88</b>   <b>59</b>		
		Ripiano legno retro ribalta Wooden shelf behind flap-door		VOLm³ Kg	Per base   For base P.   D. 480		
					0,009 2	L. 480	SL1R01321
0,012 2,5	L. 640				SL1R01331	<b>46</b>   <b>33</b>	
0,015 3,5	L. 800				SL1R01341	<b>56</b>   <b>39</b>	
0,018 4	L. 960			SL1R01351	<b>64</b>   <b>45</b>		
VOLm³ Kg	Per base   For base P.   D.576						
	0,011 2,5			L. 480	SL1R01421	<b>45</b>   <b>32</b>	
	0,015 3,4			L. 640	SL1R01431	<b>53</b>   <b>35</b>	
	0,018 4,3			L. 800	SL1R01441	<b>64</b>   <b>43</b>	
0,022 5,2	L. 960			SL1R01451	<b>72</b>   <b>48</b>		
Ripiano vetro retro ribalta Glass shelf behind flap-door				VOLm³ Kg	Per base   For base P.   D. 480		
					0,008 3,5	L. 480	SL1R02320
		0,011 5	L. 640		SL1R02330	<b>19</b>   <b>19</b>	
		0,014 6,5	L. 800		SL1R02340	<b>24</b>   <b>24</b>	
		0,017 8	L. 960	SL1R02350	<b>26</b>   <b>26</b>		
		VOLm³ Kg	Per base   For base P.   D.576				
			0,011 4	L. 480	SL1R02420	<b>18</b>   <b>18</b>	
			0,014 5,5	L. 640	SL1R02430	<b>21</b>   <b>21</b>	
			0,017 7,5	L. 800	SL1R02440	<b>26</b>   <b>26</b>	
		0,021 9	L. 960	SL1R02450	<b>29</b>   <b>29</b>		

N.B: The interior of the cabinet and open compartment has matching textured f. for heat-treated oak and oak knots finishes and matching matte lacquer for lacquers, UP surfaces, in addition to oak gesso, oak visone, oak cenere and oak castoro woods.

Il prezzo totale è dato dalla somma della SCOCCHA VUOTA (1) + FRONTALI (2) + EV. RIPIANO O DIVISORIO (3)  
 The total price is given by the sum of the EMPTY BODY (1) + FRONTS (2) + ANY SHELF OR PARTITION (3)  
 - Aggiungere sempre il top agli elementi a pag. | Always add the top to the elements on page 72

codice code	lacc. opaco matt lacq.	essenza cat. 1 wood cat. 1	essenza cat. 2 wood cat. 2	rovere lacc. matt lacq. oak	lacc. lucido glossy lacq.	superfici UP UP surface
-------------	------------------------	----------------------------	----------------------------	-----------------------------	---------------------------	-------------------------

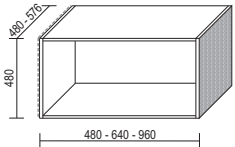
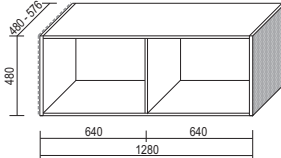
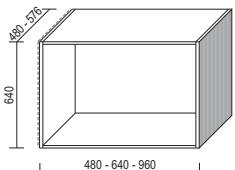
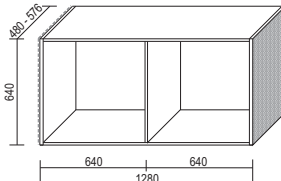
SCOCHE VUOTE   EMPTY BODIES	<p>(1) Scocca vuota elemento 1 vano Empty body for element with 1 compartment</p> 	El. terra / appoggio Free-standing / supported	P.   D. 480							
			L. 480	SL1B01423	201	214	235	242	241	
			L. 640	SL1B01433	218	226	247	254	256	
			L. 960	SL1B01453	267	270	295	303	306	
			P.   D. 576							
			L. 480	SL1B01523	221	236	256	265	268	
		L. 640	SL1B01533	237	249	273	281	286		
		L. 960	SL1B01553	291	301	326	334	342		
		Elementi sospesi Suspended	P.   D. 480							
			L. 480	SL1B11423	209	222	241	249	249	
			L. 640	SL1B11433	229	238	256	264	268	
			L. 960	SL1B11453	283	287	310	318	323	
	P.   D. 576									
	L. 480		SL1B11523	231	245	266	275	277		
	L. 640	SL1B11533	251	263	287	295	299			
	L. 960	SL1B11553	312	319	346	355	361			
	<p>Scocca vuota elemento 2 vani Empty body for element with 2 compartments</p> 	El. terra / appoggio Free-standing / supported	P.   D. 480	SL1B02463	334	323	353	360	374	
			P.   D. 576	SL1B02563	362	359	391	400	414	
			P.   D. 480	SL1B12463	357	344	373	381	397	
			P.   D. 576	SL1B12563	389	385	417	426	441	
			Elementi sospesi Suspended	P.   D. 480						
				L. 480	SL1B11424	228	241	263	273	270
		L. 640		SL1B11434	248	256	279	289	291	
		L. 960		SL1B11454	306	309	336	346	350	
P.   D. 576										
L. 480		SL1B11524		249	266	289	301	301		
L. 640		SL1B11534	273	286	310	322	323			
L. 960		SL1B11554	336	346	375	387	391			
<p>Scocca vuota elemento 1 vano Empty body for element with 1 compartment</p> 	El. terra / appoggio Free-standing / supported	P.   D. 480								
		L. 480	SL1B01424	220	231	252	262	263		
		L. 640	SL1B01434	237	245	267	277	278		
		L. 960	SL1B01454	291	292	319	329	333		
		P.   D. 576								
		L. 480	SL1B01524	240	255	278	290	292		
	L. 640	SL1B01534	259	270	295	307	309			
	L. 960	SL1B01554	317	324	353	364	372			
	Elementi sospesi Suspended	P.   D. 480								
		L. 480	SL1B11424	228	241	263	273	270		
		L. 640	SL1B11434	248	256	279	289	291		
		L. 960	SL1B11454	306	309	336	346	350		
P.   D. 576										
L. 480		SL1B11524	249	266	289	301	301			
L. 640	SL1B11534	273	286	310	322	323				
L. 960	SL1B11554	336	346	375	387	391				
<p>Scocca vuota elemento 2 vani Empty body for element with 2 compartments</p> 	El. terra / appoggio Free-standing / supported	P.   D. 480	SL1B02464	363	348	380	389	407		
		P.   D. 576	SL1B02564	396	387	423	435	452		
		P.   D. 480	SL1B12464	386	373	404	414	429		
		P.   D. 576	SL1B12564	422	416	452	464	478		
		Elementi sospesi Suspended	P.   D. 480							
			L. 480	SL1B11424	228	241	263	273	270	
	L. 640		SL1B11434	248	256	279	289	291		
	L. 960		SL1B11454	306	309	336	346	350		
	P.   D. 576									
	L. 480		SL1B11524	249	266	289	301	301		
	L. 640	SL1B11534	273	286	310	322	323			
	L. 960	SL1B11554	336	346	375	387	391			



N.B: L'interno del mobile e del vano a giorno è in materico abbinato per il rovere termotrattato e nodi, in laccato opaco in tinta per i laccati, le superfici UP e per le essenze rovere gesso, visone, cenere e castoro

Il prezzo totale è dato dalla somma della SCOCCA VUOTA (1) + FRONTALI (2) + EV. RIPIANO O DIVISORIO (3)  
 The total price is given by the sum of the EMPTY BODY (1) + FRONTS (2) + ANY SHELF OR PARTITION (3)  
 - Aggiungere sempre il top agli elementi a pag. | Always add the top to the elements on page 72

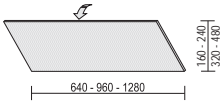
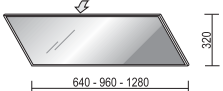
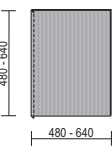
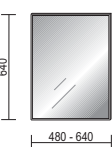
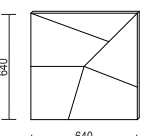
				codice code	lacc. opaco matt lacq.	essenza cat. 1 wood cat. 1	essenza cat. 2 wood cat. 2	rovere lacc. matt lacq. oak	lacc. lucido glossy lacq.	maniglia Slim	maniglia gola Groove handle	maniglia XL handle	
FRONTALI   FRONTS	<b>(2) Ribalta</b> Flap-door Possibile l'inserimento di braccetti a filo solo con maniglia, maggioranza a pag. 118 Wire hinges can only be inserted in fronts with handles. Surcharge on page 118 	VOLm <sup>3</sup> Kg	H. 160										
		0,006 1,5	L. 640	SL1A22231	75	91	103	107	88	16	39	-	
		0,008 2,5	L. 960	SL1A22251	87	107	124	129	101	19	46	-	
		0,010 3	L. 1280	SL1A22261	105	131	148	157	126	30	51	-	
		VOLm <sup>3</sup> Kg	H. 240										
		0,011 2	L. 640	SL1A22232	98	126	143	150	116	16	39	-	
		0,017 3	L. 960	SL1A22252	113	148	174	183	134	19	46	-	
		0,022 4	L. 1280	SL1A22262	135	180	214	225	166	30	51	-	
		VOLm <sup>3</sup> Kg	H. 320										
		0,014 3,2	L. 640	SL1A22233	105	130	150	156	126	16	39	-	
		0,021 4,5	L. 960	SL1A22253	121	152	183	193	147	19	46	-	
		0,028 6	L. 1280	SL1A22263	145	185	224	237	180	30	51	-	
	VOLm <sup>3</sup> Kg	H. 480											
	0,021 4,5	L. 640	SL1A22234	129	167	195	205	159	16	39	-		
	0,031 6,5	L. 960	SL1A22254	151	198	241	255	189	19	46	-		
	0,041 8,5	L. 1280	SL1A22264	187	275	330	349	241	30	51	-		
		<b>Ribalta vetro SLIM</b> , non è possibile l'inserimento di braccetti a filo SLIM glass flap-door, lid supports cannot be inserted 	VOLm <sup>3</sup> Kg	H. 320		vetro   glass (cat 1)	vetro   glass (cat 2)						
	0,015 4	L. 640	SL1A23233	207	225								
	0,022 5,5	L. 960	SL1A23253	252	283								
	0,029 7	L. 1280	SL1A23263	316	357								
	<b>Ante battenti</b> , specificare nell'ordine se apertura dx o sx Hinged door, in the order specify if the opening is rh or lh												
	<b>Anta legno   Wooden door</b> 	VOLm <sup>3</sup> Kg	H. 480										
0,015 3,3	L. 480	SL1A20243	67	89	102	110	90	10	37	38			
0,019 4,3	L. 640	SL1A20263	74	101	117	127	104	10	37	38			
VOLm <sup>3</sup> Kg	H. 640												
0,021 4,2	L. 480	SL1A20244	74	101	117	127	104	11	39	44			
0,027 5,7	L. 640	SL1A20264	85	119	139	151	124	11	39	44			
	<b>Anta vetro SLIM   SLIM glass door</b> 	VOLm <sup>3</sup> Kg	H. 640		vetro   glass (cat 1)	vetro   glass (cat 2)							
0,022 5,5	L. 480	SL1A21244	192	227									
0,028 7	L. 640	SL1A21264	219	265									
	<b>Anta legno CONCRETE   CONCRETE wooden door</b> 	VOLm <sup>3</sup> Kg	H. 640		lacc. opaco matt lacq.			eff. resina resin effect f.					
0,034 8,5	L. 640	SL1A20364	361				401						



N.B: L'interno del mobile e del vano a giorno è in materico abbinato per il rovere termotrattato e nodi, in laccato opaco in tinta per i laccati, le superfici UP e per le essenze rovere gesso, visone, cenere e castoro

Il prezzo totale è dato dalla somma della SCOCCA VUOTA (1) + FRONTALI (2) + EV. RIPIANO O DIVISORIO (3)

The total price is given by the sum of the EMPTY BODY (1) + FRONTS (2) + ANY SHELF OR PARTITION (3)

- Aggiungere sempre il top agli elementi a pag. | Always add the top to the elements on page 72

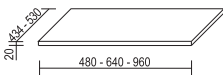
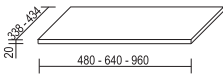
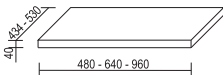
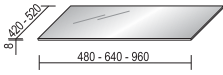
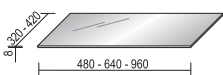
				codice code	lacc. opaco matt lacq.	materico textured finish		
RIPIANI   SHELVES	(3) Ripiano legno retro anta battente Wooden shelf behind hinged door		VOLm³ Kg	Per base   For base P.   D. 480				
			0,011 2,5	L. 480	SL1R01421	45	32	
			0,015 3,4	L. 640	SL1R01431	53	35	
			0,022 5,2	L. 960	SL1R01451	72	48	
			VOLm³ Kg	Per base   For base P.   D. 576				
			0,013 3	L. 480	SL1R01521	50	34	
		0,018 4	L. 640	SL1R01531	60	37		
		0,027 6	L. 960	SL1R01551	78	50		
		Ripiano legno retro ribalta Wooden shelf behind flap-door		VOLm³ Kg	Per base   For base P.   D. 480			
				0,009 2	L. 480	SL1R01321	39	29
				0,012 2,5	L. 640	SL1R01331	46	33
				0,018 4	L. 960	SL1R01351	64	45
	VOLm³ Kg			Per base   For base P.   D. 576				
	0,011 2,5			L. 480	SL1R01421	45	32	
	0,015 3,4	L. 640	SL1R01431	53	35			
	0,022 5,2	L. 960	SL1R01451	72	48			
	Divisorio legno sp. 40 Wooden partition th. 40		Kg	Per base   For base P.   D. 480				
			5	L. 480	SL1R40422	49	35	
			6,8	L. 640	SL1R40432	59	38	
			10,5	L. 960	SL1R40452	79	54	
			Kg	Per base   For base P.   D. 576				
			6	L. 480	SL1R40522	56	38	
		8,3	L. 640	SL1R40532	65	42		
		12,7	L. 960	SL1R40552	88	59		
Ripiano vetro retro anta battente Glass shelf behind hinged door			VOLm³ Kg	Per base   For base P.   D. 480		vetro   glass		
			0,011 4	L. 480	SL1R02420	18		
			0,014 5,5	L. 640	SL1R02430	21		
			0,021 9	L. 960	SL1R02450	29		
	VOLm³ Kg		Per base   For base P.   D. 576			vetro   glass		
	0,013 5,5		L. 480	SL1R02520	20			
	0,017 7,5	L. 640	SL1R02530	24				
	0,026 11,5	L. 960	SL1R02550	34				
	Ripiano vetro retro ribalta Glass shelf behind flap-door		VOLm³ Kg	Per base   For base P.   D. 480		vetro   glass		
			0,008 3,5	L. 480	SL1R02320	17		
			0,011 5	L. 640	SL1R02330	19		
			0,017 8	L. 960	SL1R02350	26		
VOLm³ Kg			Per base   For base P.   D. 576			vetro   glass		
0,011 4			L. 480	SL1R02420	18			
0,014 5,5		L. 640	SL1R02430	21				
0,021 9		L. 960	SL1R02450	29				



# TOP IN LEGNO PER BASI ED ELEMENTI | WOODEN TOP FOR BASES AND ELEMENTS P. | D. 484-580

N.B: L'interno del mobile e del vano a giorno è in materico abbinato per il rovere termotrattato e nodi, in laccato opaco in tinta per i laccati, le superfici UP e per le essenze rovere gesso, visone, cenere e castoro

- Aggiungere sempre il top a basi ed elementi   Always add the top to the bases and elements	codice	lacc. opaco	essenza cat. 1	essenza cat. 2	rovere lacc.	lacc. lucido
	code	matt lacq.	wood cat. 1	wood cat. 2	matt lacq. oak	glossy lacq.

superfici UP  
UP surface



## P. | D. 484

VOLm³	Kg
0,015	2,8
0,020	3,5
0,029	5
0,033	5,8
0,038	6,5
0,043	7,5
0,047	8
0,057	9,5
0,066	11
0,075	13,5
0,080	14
0,084	14,5
0,093	16,3
0,103	17,8
0,112	19,3

L. 480	SL1T014B0	46	57	65	71	63
L. 640	SL1T014C0	52	65	75	81	78
L. 960	SL1T014D0	69	96	108	118	106
L. 1120	SL1T014E0	77	106	123	133	121
L. 1280	SL1T014F0	85	120	138	150	135
L. 1440	SL1T014G0	90	130	150	164	150
L. 1600	SL1T014H0	105	139	160	175	173
L. 1920	SL1T014L0	119	159	183	201	198
L. 2240	SL1T014M0	138	197	227	248	229
L. 2560	SL1T014N0	155	206	238	262	259
L. 2720	SL1T014O0	166	224	259	283	278
L. 2880	SL1T014P0	173	226	261	288	291
L. 3200	SL1T014R0	197	278	321	350	327
L. 3520	SL1T014S0	218	297	343	375	359
L. 3840	SL1T014T0	237	301	346	382	389

## P. | D. 580

VOLm³	Kg
0,018	3,2
0,023	4
0,034	6
0,040	7
0,045	8
0,051	8,5
0,056	9,5
0,067	11,5
0,078	13
0,089	15
0,094	16,5
0,100	17,5
0,111	19,3
0,121	21
0,132	23

L. 480	SL1T015B0	50	67	77	83	75
L. 640	SL1T015C0	57	81	94	102	89
L. 960	SL1T015D0	77	106	123	133	124
L. 1120	SL1T015E0	86	121	139	152	139
L. 1280	SL1T015F0	94	134	155	169	158
L. 1440	SL1T015G0	104	147	169	185	174
L. 1600	SL1T015H0	119	171	196	214	201
L. 1920	SL1T015L0	138	213	246	267	229
L. 2240	SL1T015M0	157	227	261	286	265
L. 2560	SL1T015N0	177	275	317	345	302
L. 2720	SL1T015O0	191	283	326	356	322
L. 2880	SL1T015P0	201	286	328	360	337
L. 3200	SL1T015R0	224	319	368	403	378
L. 3520	SL1T015S0	247	348	401	440	420
L. 3840	SL1T015T0	272	380	438	480	456

**TOP LAMINAM® PER BASI ED ELEMENTI | LAMINAM® TOP FOR BASES AND ELEMENTS P. | D. 484-580**

N.B: The interior of the cabinet and open compartment has matching textured f. for heat-treated oak and oak knots finishes and matching matte lacquer for lacquers, UP surfaces, in addition to oak gesso, oak visone, oak cenere and oak castoro woods.

- Aggiungere sempre il top a basi ed elementi | Always add the top to the bases and elements

codice code	Laminam® opaco	Laminam® lucido
	Laminam® matt	Laminam® glossy



VOLm³	Kg
0,016	5,2
0,020	6,6
0,030	9,5
0,035	11
0,040	12,4
0,044	13,8
0,050	15,3
0,060	18,2
0,070	21
0,077	23,9
0,081	25,4
0,086	26,8

VOLm³	Kg
0,019	6
0,024	7,8
0,035	11,2
0,040	12,9
0,046	14,6
0,052	16,4
0,057	18,1
0,068	21,5
0,080	24,9
0,090	28,4
0,096	30,1
0,100	31,8

**P. | D. 484**

L.	SL1T114B0	165	182
L. 480	SL1T114B0	165	182
L. 640	SL1T114C0	196	219
L. 960	SL1T114D0	258	291
L. 1120	SL1T114E0	289	328
L. 1280	SL1T114F0	320	363
L. 1440	SL1T114G0	350	400
L. 1600	SL1T114H0	382	437
L. 1920	SL1T114L0	445	510
L. 2240	SL1T114M0	517	592
L. 2560	SL1T114N0	587	674
L. 2720	SL1T114O0	623	714
L. 2880	SL1T114P0	658	755

**P. | D. 580**

L.	SL1T115B0	183	204
L. 480	SL1T115B0	183	204
L. 640	SL1T115C0	220	246
L. 960	SL1T115D0	292	331
L. 1120	SL1T115E0	328	374
L. 1280	SL1T115F0	364	416
L. 1440	SL1T115G0	400	458
L. 1600	SL1T115H0	437	502
L. 1920	SL1T115L0	520	598
L. 2240	SL1T115M0	603	693
L. 2560	SL1T115N0	685	788
L. 2720	SL1T115O0	727	836
L. 2880	SL1T115P0	768	884

N.B: L'interno del mobile e del vano a giorno è in materico abbinato per il rovere termotrattato e nodi, in laccato opaco in tinta per i laccati, le superfici UP e per le essenze rovere gesso, visone, cenere e castoro

- Aggiungere sempre il top a basi ed elementi | Always add the top to the bases and elements  
 - Disponibili in finitura brown, bianco, ottone, titanio | Available in a brown, white, brass or titanium finish.

**codice**  
code

**metallo**  
metal

**luce LED**  
LED light

Top in metallo  
 intero fino a L. 2560, per misure superiori accostare più top  
 Metal top  
 One piece up to a length of 2560 mm.  
 For larger sizes, multiple tops will be placed alongside each other.



VOLm³	Kg
0,023	10
0,030	13
0,033	14,5
0,037	15,5
0,044	19,5
0,051	22,5
0,059	25,5

**Top**

Top	code	metal	LED light
L. 960	SL1T214D0	<b>246</b>	-
L. 1280	SL1T214F0	<b>268</b>	-
L. 1440	SL1T214G0	<b>301</b>	-
L. 1600	SL1T214H0	<b>324</b>	-
L. 1920	SL1T214I0	<b>347</b>	-
L. 2240	SL1T214M0	<b>370</b>	-
L. 2560	SL1T214N0	<b>401</b>	-

Top completo di alzatina + fianchi, in metallo  
 top intero fino a L. 2560, per misure superiori accostare più top,  
 da completare sempre con fianchi di chiusura.  
 Luce led optional (luce calda 3000°K), comprensiva di alimentatore da  
 collegare alla rete elettrica della stanza.  
 Top with a metal back panel and side panels.  
 The top comes as a single piece for lengths up to 2560 mm.  
 For larger sizes, multiple tops will be placed alongside each other.  
 Always comes with closing-off side panels.  
 The optional LED light (3000K warm light) comes with a power pack  
 that must be connected to the mains in the room.

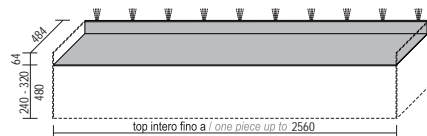

VOLm³	Kg
0,031	11
0,042	14,5
0,047	16,5
0,052	18
0,062	21,5
0,072	25
0,082	28

**Top con Alzatina**  
 Top with back panel

Top con Alzatina	code	metal	LED light
L. 960	SL1T314D0	<b>296</b>	<b>103</b>
L. 1280	SL1T314F0	<b>324</b>	<b>116</b>
L. 1440	SL1T314G0	<b>366</b>	<b>127</b>
L. 1600	SL1T314H0	<b>390</b>	<b>143</b>
L. 1920	SL1T314I0	<b>421</b>	<b>179</b>
L. 2240	SL1T314M0	<b>448</b>	<b>196</b>
L. 2560	SL1T314N0	<b>486</b>	<b>211</b>

optional led

N.B: I fianchi in metallo sono abbinabili solo ai top in metallo con alzatina.  
 N.B: The metal sides can only be combined with metal tops that have a back panel.



VOLm³	Kg
0,012	3,3
0,014	4
0,020	5,2

**+**

**Coppia fianchi**  
 Pair of side panels

Coppia fianchi	code	metal	LED light
H. 304	SL1XF0124	<b>162</b>	-
H. 384	SL1XF0134	<b>175</b>	-
H. 544	SL1XF0144	<b>198</b>	-

N.B: The interior of the cabinet and open compartment has matching textured f. for heat-treated oak and oak knots finishes and matching matte lacquer for lacquers, UP surfaces, in addition to oak gesso, oak visone, oak cenere and oak castoro woods.

- Aggiungere solo se necessario il top a pag. | Only if necessary, add the top on page 97  
 - Apertura standard "push and pull" | Standard 'push and pull' opening  
 - Possibile l'inserimento di braccetti a filo solo con maniglia e con apertura verso il basso, maggiorazione a pag. 118  
 - Lid supports can only be inserted in fronts with handles and downwards-opening doors.  
 Surcharge on page 118

		codice code	lacc. opaco matt lacq.	essenza cat. 1 wood cat. 1	essenza cat. 2 wood cat. 2	rovere lacc. matt lacq. oak	lacc. lucido glossy lacq.
							superfici UP UP surface

**Ribalta pensile con 1 anta**  
 specificare nell'ordine il senso di apertura  
 Flap-door wall unit with 1 door  
 specify the opening direction in the order

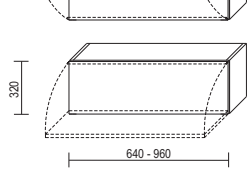

VOLm³	Kg	L. 640						
0,104	14	P.   D. 384	SL1PRL331	291	349	403	414	366
0,127	16	P.   D. 480	SL1PRL431	309	371	428	439	389
		Maniglia Slim   Slim handle		16	16	16	16	16
		Maniglia gola   Groove handle		39	39	39	39	39

**Ribalta pensile con 1 anta**  
 specificare nell'ordine il senso di apertura  
 Flap-door wall unit with 1 door  
 specify the opening direction in the order

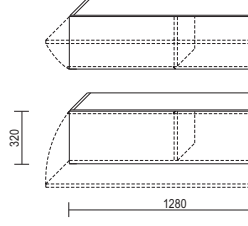

VOLm³	Kg	L. 960						
0,153	19	P.   D. 384	SL1PRL351	345	407	478	493	435
0,187	22	P.   D. 480	SL1PRL451	366	434	507	523	461
		Maniglia Slim   Slim handle		19	19	19	19	19
		Maniglia gola   Groove handle		46	46	46	46	46

**Ribalta pensile con 1 anta**  
 specificare nell'ordine il senso di apertura  
 Flap-door wall unit with 1 door  
 specify the opening direction in the order

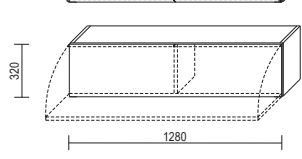

VOLm³	Kg							
0,201	27	P.   D. 384	SL1PRL361	437	507	596	613	550
0,247	31	P.   D. 480	SL1PRL461	464	539	633	651	583
		Maniglia Slim   Slim handle		30	30	30	30	30
		Maniglia gola   Groove handle		51	51	51	51	51

**Ribalta pensile con 1 anta**  
 specificare nell'ordine il senso di apertura  
 Flap-door wall unit with 1 door  
 specify the opening direction in the order



VOLm³	Kg							
0,250	32	P.   D. 384	SL1PRL371	498	581	674	691	637
0,307	37	P.   D. 480	SL1PRL471	530	618	716	734	676
		Maniglia Slim   Slim handle		35	35	35	35	35
		Maniglia gola   Groove handle		58	58	58	58	58

**Ribalta pensile con 1 anta**  
 specificare nell'ordine il senso di apertura  
 Flap-door wall unit with 1 door  
 specify the opening direction in the order

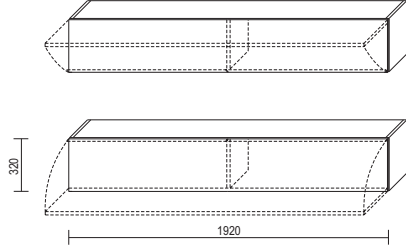

VOLm³	Kg							
0,299	36	P.   D. 384	SL1PRL381	557	657	762	786	721
0,367	42	P.   D. 480	SL1PRL481	591	699	812	836	766
		Maniglia Slim   Slim handle		37	37	37	37	37
		Maniglia gola   Groove handle		64	64	64	64	64

Ulteriori combinazioni di aperture e finiture sono possibili utilizzando le scocche vuote a pag. | Additional finishes and opening combinations are possible using the empty bodies on page 78

PENSILI  
WALL UNITS



N.B: L'interno del mobile e del vano a giorno è in materico abbinato per il rovere termotrattato e nodi, in laccato opaco in tinta per i laccati, le superfici UP e per le essenze rovere gesso, visone, cenere e castoro

		codice code	lacc. opaco matt lacq.	essenza cat. 1 wood cat. 1	essenza cat. 2 wood cat. 2	rovere lacc. matt lacq. oak	lacc. lucido glossy lacq.	superfici UP UP surface
- Aggiungere solo se necessario il top a pag.   Only if necessary, add the top on page 97 - Apertura standard "push and pull"   Standard 'push and pull' opening - Possibile l'inserimento di braccetti a filo solo con maniglia e con apertura verso il basso, maggiorazione a pag. 118 - Lid supports can only be inserted in fronts with handles and downwards-opening doors. Surcharge on page 118								
Ribalta pensile con 1 anta specificare nell'ordine il senso di apertura Flap-door wall unit with 1 door specify the opening direction in the order								
	VOLm³ Kg 0,167 19 0,190 21	<b>L. 640</b> P.   D. 384 P.   D. 480 Maniglia Slim   Slim handle Maniglia gola   Groove handle	SL1PRL332 SL1PRL432	<b>343</b> <b>364</b> 16 39	<b>408</b> <b>432</b> 16 39	<b>473</b> <b>501</b> 16 39	<b>488</b> <b>519</b> 16 39	<b>450</b> <b>478</b> 16 39
	VOLm³ Kg 0,216 24 0,277 28	<b>L. 960</b> P.   D. 384 P.   D. 480 Maniglia Slim   Slim handle Maniglia gola   Groove handle	SL1PRL352 SL1PRL452	<b>410</b> <b>432</b> 19 46	<b>479</b> <b>510</b> 19 46	<b>565</b> <b>599</b> 19 46	<b>585</b> <b>621</b> 19 46	<b>537</b> <b>569</b> 19 46
Ribalta pensile con 1 anta specificare nell'ordine il senso di apertura Flap-door wall unit with 1 door specify the opening direction in the order								
	VOLm³ Kg 0,266 32 0,363 45	P.   D. 384 P.   D. 480 Maniglia Slim   Slim handle Maniglia gola   Groove handle	SL1PRL362 SL1PRL462	<b>523</b> <b>555</b> 30 51	<b>630</b> <b>665</b> 30 51	<b>739</b> <b>780</b> 30 51	<b>763</b> <b>806</b> 30 51	<b>689</b> <b>730</b> 30 51
	VOLm³ Kg 0,313 37 0,450 47	P.   D. 384 P.   D. 480 Maniglia Slim   Slim handle Maniglia gola   Groove handle	SL1PRL372 SL1PRL472	<b>598</b> <b>635</b> 35 58	<b>721</b> <b>761</b> 35 58	<b>837</b> <b>882</b> 35 58	<b>862</b> <b>909</b> 35 58	<b>798</b> <b>846</b> 35 58
Ribalta pensile con 1 anta specificare nell'ordine il senso di apertura Flap-door wall unit with 1 door specify the opening direction in the order								
	VOLm³ Kg 0,362 41 0,536 53	P.   D. 384 P.   D. 480 Maniglia Slim   Slim handle Maniglia gola   Groove handle	SL1PRL382 SL1PRL482	<b>675</b> <b>715</b> 37 64	<b>812</b> <b>858</b> 37 64	<b>943</b> <b>998</b> 37 64	<b>974</b> <b>1.032</b> 37 64	<b>904</b> <b>959</b> 37 64

Ulteriori combinazioni di aperture e finiture sono possibili utilizzando le scocche vuote a pag. | Additional finishes and opening combinations are possible using the empty bodies on page 78

N.B: The interior of the cabinet and open compartment has matching textured f. for heat-treated oak and oak knots finishes and matching matte lacquer for lacquers, UP surfaces, in addition to oak gesso, oak visone, oak cenere and oak castoro woods.

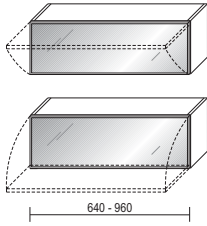
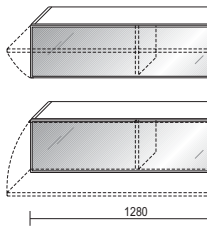
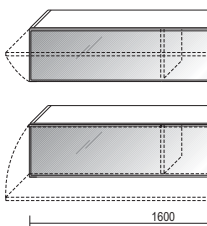
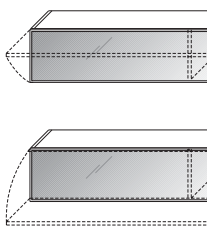
				codice code	lacc. opaco matt lacq.	essenza cat. 1 wood cat. 1	essenza cat. 2 wood cat. 2	rovere lacc. matt lacq. oak	lacc. lucido glossy lacq.	superfici UP UP surface
- Aggiungere solo se necessario il top a pag.   Only if necessary, add the top on page 97 - Solo apertura "push and pull"   Only "Push and pull" opening - Non è possibile l'inserimento di braccetti a filo   Lid supports cannot be inserted										
Ribalta pensile con 1 anta vetro SLIM specificare nell'ordine il senso di apertura Flap-door wall unit with 1 SLIM glass door specify the opening direction in the order										
		VOLm <sup>3</sup> Kg	<b>L. 640</b>							
		0,104 15	P.   D. 384 vetro   glass (cat 1)	SL1PRV331	<b>393</b>	<b>426</b>	<b>460</b>	<b>465</b>	<b>447</b>	
			P.   D. 384 vetro   glass (cat 2)	SL1PRV331	<b>411</b>	<b>444</b>	<b>478</b>	<b>483</b>	<b>465</b>	
		VOLm <sup>3</sup> Kg	<b>L. 640</b>							
		0,127 17	P.   D. 480 vetro   glass (cat 1)	SL1PRV431	<b>411</b>	<b>448</b>	<b>485</b>	<b>490</b>	<b>470</b>	
			P.   D. 480 vetro   glass (cat 2)	SL1PRV431	<b>429</b>	<b>466</b>	<b>503</b>	<b>508</b>	<b>488</b>	
Ribalta pensile con 1 anta vetro SLIM specificare nell'ordine il senso di apertura Flap-door wall unit with 1 SLIM glass door specify the opening direction in the order										
		VOLm <sup>3</sup> Kg	<b>P.   D. 384</b>							
		0,201 28	vetro   glass (cat 1)	SL1PRV361	<b>608</b>	<b>638</b>	<b>688</b>	<b>692</b>	<b>686</b>	
			vetro   glass (cat 2)	SL1PRV361	<b>649</b>	<b>679</b>	<b>729</b>	<b>733</b>	<b>727</b>	
		VOLm <sup>3</sup> Kg	<b>P.   D. 480</b>							
		0,247 32	vetro   glass (cat 1)	SL1PRV461	<b>635</b>	<b>670</b>	<b>725</b>	<b>730</b>	<b>719</b>	
			vetro   glass (cat 2)	SL1PRV461	<b>676</b>	<b>711</b>	<b>766</b>	<b>771</b>	<b>760</b>	
Ribalta pensile con 1 anta vetro SLIM specificare nell'ordine il senso di apertura Flap-door wall unit with 1 SLIM glass door specify the opening direction in the order										
		VOLm <sup>3</sup> Kg	<b>P.   D. 384</b>							
		0,250 33,5	vetro   glass (cat 1)	SL1PRV371	<b>692</b>	<b>725</b>	<b>780</b>	<b>784</b>	<b>786</b>	
			vetro   glass (cat 2)	SL1PRV371	<b>746</b>	<b>779</b>	<b>834</b>	<b>838</b>	<b>840</b>	
		VOLm <sup>3</sup> Kg	<b>P.   D. 480</b>							
		0,307 38	vetro   glass (cat 1)	SL1PRV471	<b>724</b>	<b>762</b>	<b>822</b>	<b>827</b>	<b>825</b>	
			vetro   glass (cat 2)	SL1PRV471	<b>778</b>	<b>816</b>	<b>876</b>	<b>881</b>	<b>879</b>	
Ribalta pensile con 1 anta vetro SLIM specificare nell'ordine il senso di apertura Flap-door wall unit with 1 SLIM glass door specify the opening direction in the order										
		VOLm <sup>3</sup> Kg	<b>P.   D. 384</b>							
		0,299 37,5	vetro   glass (cat 1)	SL1PRV381	<b>766</b>	<b>807</b>	<b>871</b>	<b>876</b>	<b>878</b>	
			vetro   glass (cat 2)	SL1PRV381	<b>835</b>	<b>876</b>	<b>940</b>	<b>945</b>	<b>947</b>	
		VOLm <sup>3</sup> Kg	<b>P.   D. 480</b>							
		0,367 43	vetro   glass (cat 1)	SL1PRV481	<b>800</b>	<b>849</b>	<b>921</b>	<b>926</b>	<b>923</b>	
			vetro   glass (cat 2)	SL1PRV481	<b>869</b>	<b>918</b>	<b>990</b>	<b>995</b>	<b>992</b>	

Ulteriori combinazioni di aperture e finiture sono possibili utilizzando le scocche vuote a pag. | Additional finishes and opening combinations are possible using the empty bodies on page 78

N.B: L'interno del mobile e del vano a giorno è in materico abbinato per il rovere temottrattato e nodi, in laccato opaco in tinta per i laccati, le superfici UP e per le essenze rovere gesso, visone, cenere e castoro

Il prezzo totale è dato dalla somma della SCOCCHA VUOTA (1) + FRONTALI (2) + EV. RIPIANO (3) The total price is given by the sum of the EMPTY BODY (1) + FRONTS (2) + ANY SHELF (3)		codice code	lacc. opaco matt lacq.	essenza cat. 1 wood cat. 1	essenza cat. 2 wood cat. 2	rovere lacc. matt lacq. oak	lacc. lucido glossy lacq.	maniglia Slim	maniglia Groove			
							superfici UP UP surface	Slim handle	Groove handle			
SCOCHE VUOTE   EMPTY BODIES	(1) Scocca vuota ribalta 1 vano Empty body for flap-door wall unit with 1 compartment	H. 320	L. 640	SL1P05331	186	219	253	258	240			
			L. 960	SL1P05351	224	255	295	300	288			
		H. 480	L. 640	SL1P05332	214	241	278	283	291			
			L. 960	SL1P05352	259	281	324	330	348			
		(1) Scocca vuota ribalta 2 vani Empty body for flap-door wall unit with 2 compartments	H. 320	L. 1280	SL1P05361	292	322	372	376	370		
				L. 1600	SL1P05371	337	370	425	429	431		
	L. 1920			SL1P05381	380	421	485	490	492			
	H. 480		L. 1280	SL1P05362	336	355	409	414	448			
		L. 1600	SL1P05372	388	408	468	474	522				
		L. 1920	SL1P05382	437	464	534	539	596				
RIPIANI   SHELVES	(3) Ripiano legno retro ribalta Wooden shelf behind flap-door		VOLm³ Kg		lacc. opaco matt lacq.	materico textured finish						
			0,011	2,5			L. 640	SL1R01231	38	27		
			0,014	3			L. 800	SL1R01241	47	33		
	0,016	3,5	L. 960	SL1R01251	54	38						
	(3) Ripiano vetro retro ribalta Glass shelf behind flap-door		VOLm³ Kg		vetro   glass							
			0,008	3		L. 640	SL1R02230	17				
0,010			3,8	L. 800		SL1R02240	21					
		0,012	4,5	L. 960	SL1R02250	22						

N.B: The interior of the cabinet and open compartment has matching textured f. for heat-treated oak and oak knots finishes and matching matte lacquer for lacquers, UP surfaces, in addition to oak gesso, oak visone, oak cenere and oak castoro woods.

		codice code	lacc. opaco matt lacq.	essenza cat. 1 wood cat. 1	essenza cat. 2 wood cat. 2	rovere lacc. matt lacq. oak	lacc. lucido glossy lacq. superfici UP UP surface	maniglia Slim handle	maniglia gola Groove handle		
SCOCHE VUOTE   EMPTY BODIES	(1) Scocca vuota ribalta 1 vano Empty body for flap-door wall unit with 1 compartment	H. 320									
		L. 640	SL1P05431	204	241	278	283	263			
		L. 960	SL1P05451	245	282	324	330	314			
		H. 480									
		L. 640	SL1P05432	235	265	306	314	319			
		L. 960	SL1P05452	281	312	358	366	380			
	SCOCHE VUOTE   EMPTY BODIES	Scocca vuota ribalta 2 vani Empty body for flap-door wall unit with 2 compartments	H. 320								
			L. 1280	SL1P05461	319	354	409	414	403		
			L. 1600	SL1P05471	369	407	467	472	470		
			L. 1920	SL1P05481	414	463	535	540	537		
			H. 480								
			L. 1280	SL1P05462	368	390	450	457	489		
SCOCHE VUOTE   EMPTY BODIES	Scocca vuota ribalta 2 vani Empty body for flap-door wall unit with 2 compartments	L. 1600	SL1P05472	425	448	513	521	570			
		L. 1920	SL1P05482	477	510	589	597	651			
		RIPIANI   SHELVES	(3) Ripiano legno retro ribalta Wooden shelf behind flap-door	VOLm <sup>3</sup> Kg							
				0,012 2,5	L. 640	SL1R01331	46	33			
				0,015 3,5	L. 800	SL1R01341	56	39			
				0,018 4	L. 960	SL1R01351	64	45			
VOLm <sup>3</sup> Kg											
0,011 5	L. 640			SL1R02330	19						
0,014 6,5	L. 800	SL1R02340	24								
0,017 8	L. 960	SL1R02350	26								
RIPIANI   SHELVES	(3) Ripiano vetro retro ribalta Glass shelf behind flap-door	VOLm <sup>3</sup> Kg									
		0,011 5	L. 640	SL1R02330	19						
		0,014 6,5	L. 800	SL1R02340	24						
		0,017 8	L. 960	SL1R02350	26						
		VOLm <sup>3</sup> Kg									
		0,011 5	L. 640	SL1R02330	19						

# SCOCHE VUOTE per ribalte pensili | EMPTY BODIES for flap-door wall units P. | D. 384-480

N.B: L'interno del mobile e del vano a giorno è in materico abbinato per il rovere temotattato e nodi, in laccato opaco in tinta per i laccati, le superfici UP e per le essenze rovere gesso, visone, cenere e castoro

Il prezzo totale è dato dalla somma della SCOCCA VUOTA (1) + FRONTALI (2) + EV. RIPIANO (3) The total price is given by the sum of the EMPTY BODY (1) + FRONTS (2) + ANY SHELF (3)		codice code	lacc. opaco matt lacq.	essenza cat. 1 wood cat. 1	essenza cat. 2 wood cat. 2	rovere lacc. matt lacq. oak	lacc. lucido glossy lacq.	maniglia Slim	maniglia gola		
										superfici UP UP surface	Slim handle
<p>(2) Ribalta legno   Wooden Flap-door</p> <p>Specificare nell'ordine il senso di apertura. Possibile l'inserimento di braccetti a filo solo con maniglia e con apertura verso il basso, maggiorazione a pag. 118. Specify the opening direction in the order. Lid supports can only be inserted in fronts with handles and downwards-opening doors. Surcharge on page 118</p>											
		VOLm <sup>3</sup> Kg	H. 320								
		0,014 3,2	L. 640	SL1A22233	105	130	150	156	126	16	39
		0,021 4,5	L. 960	SL1A22253	121	152	183	193	147	19	46
		0,028 6	L. 1280	SL1A22263	145	185	224	237	180	30	51
		0,035 7,5	L. 1600	SL1A22273	161	211	249	262	206	35	58
		0,042 8,5	L. 1920	SL1A22283	177	236	277	296	229	37	64
		VOLm <sup>3</sup> Kg	H. 480								
		0,021 4,5	L. 640	SL1A22234	129	167	195	205	159	16	39
		0,031 6,5	L. 960	SL1A22254	151	198	241	255	189	19	46
		0,041 8,5	L. 1280	SL1A22264	187	275	330	349	241	30	51
		0,051 10,5	L. 1600	SL1A22274	210	313	369	388	276	35	58
		0,061 12,5	L. 1920	SL1A22284	238	348	409	435	308	37	64
		<p>Ribalta vetro SLIM   SLIM Glass flap-door</p> <p>specificare nell'ordine il senso di apertura. Non è possibile l'inserimento di braccetti a filo. specify the opening direction in the order. Lid supports cannot be inserted.</p>									
				VOLm <sup>3</sup> Kg	H. 320						
0,015 4	L. 640			SL1A23233	vetro   glass (cat 1) 207	vetro   glass (cat 2) 225					
0,022 5,5	L. 960			SL1A23253	252	283					
0,029 7	L. 1280			SL1A23263	316	357					
0,036 8,5	L. 1600			SL1A23273	355	409					
0,043 10	L. 1920			SL1A23283	386	455					

FRONTALI | FRONTS

# PENSILI ANTA BATTENTE A TERRA O SOSPESI | FREE-STANDING OR SUSPENDED HINGED-DOOR WALL UNITS P. | D. 384

N.B: The interior of the cabinet and open compartment has matching textured f. for heat-treated oak and oak knots finishes and matching matte lacquer for lacquers, UP surfaces, in addition to oak gesso, oak visone, oak cenere and oak castoro woods.

- Aggiungere solo se necessario il top a pag.   Only if necessary, add the top on page 97 - Apertura standard "push and pull"   Standard 'push and pull' opening - Specificare nell'ordine se a terra o sospesi   In the order, specify whether positioned free-standing or supported		codice code	lacc. opaco matt lacq.	essenza cat. 1 wood cat. 1	essenza cat. 2 wood cat. 2	rovere lacc. matt lacq. oak	lacc. lucido glossy lacq.	maniglia Slim	maniglia gola Groove	maniglia XL	
							superfici UP UP surface	Slim handle	Groove handle	XL handle	
<b>Pensile con 1 anta</b> specificare nell'ordine se apertura dx o sx; sempre ripiano vetro dietro l'anta Wall unit with 1 door, in the order, specify if the opening is rh or lh; always glass shelf behind the door											
	VOLm <sup>3</sup> Kg										
	0,079 12	L. 320	SL1PBL312	<b>219</b>	<b>264</b>	<b>302</b>	<b>316</b>	<b>276</b>	10	37	-
	0,115 15	L. 480	SL1PBL322	<b>254</b>	<b>304</b>	<b>345</b>	<b>366</b>	<b>326</b>	10	37	38
	0,150 19	L. 640	SL1PBL332	<b>285</b>	<b>336</b>	<b>384</b>	<b>409</b>	<b>372</b>	10	37	38
<b>Pensile con 1 anta</b> specificare nell'ordine se apertura dx o sx; sempre ripiano vetro dietro l'anta Wall unit with 1 door, in the order, specify if the opening is rh or lh; always glass shelf behind the door											
	VOLm <sup>3</sup> Kg										
	0,104 16	L. 320	SL1PBL313	<b>248</b>	<b>302</b>	<b>345</b>	<b>363</b>	<b>313</b>	11	39	-
	0,150 20	L. 480	SL1PBL323	<b>286</b>	<b>345</b>	<b>393</b>	<b>418</b>	<b>372</b>	11	39	44
	0,196 25,5	L. 640	SL1PBL333	<b>324</b>	<b>387</b>	<b>443</b>	<b>472</b>	<b>429</b>	11	39	44
<b>Pensile con 1 anta</b> specificare nell'ordine se apertura dx o sx; sempre ripiani vetro dietro l'anta Wall unit with 1 door, in the order, specify if the opening is rh or lh; always glass shelves behind the door											
	VOLm <sup>3</sup> Kg										
	0,153 18,5	L. 320	SL1PBL315	<b>334</b>	<b>397</b>	<b>453</b>	<b>477</b>	<b>426</b>	17	46	-
	0,220 29	L. 480	SL1PBL325	<b>382</b>	<b>454</b>	<b>516</b>	<b>548</b>	<b>494</b>	17	46	-
	0,288 36,5	L. 640	SL1PBL335	<b>434</b>	<b>513</b>	<b>584</b>	<b>623</b>	<b>573</b>	17	46	-
<b>Pensile con 1 anta</b> specificare nell'ordine se apertura dx o sx; sempre ripiani vetro dietro l'anta Wall unit with 1 door, in the order, specify if the opening is rh or lh; always glass shelves behind the door											
	VOLm <sup>3</sup> Kg										
	0,201 30	L. 320	SL1PBL316	<b>422</b>	<b>494</b>	<b>562</b>	<b>593</b>	<b>538</b>	21	51	-
	0,291 38	L. 480	SL1PBL326	<b>478</b>	<b>559</b>	<b>636</b>	<b>675</b>	<b>619</b>	21	51	-
	0,381 48	L. 640	SL1PBL336	<b>544</b>	<b>638</b>	<b>725</b>	<b>773</b>	<b>717</b>	21	51	-
<b>Pensile con 2 ante, specificare nell'ordine se apertura dx o sx;</b> il ripiano di divisione tra le ante è fisso in legno, gli altri sono sempre vetro Wall unit with 2 doors, in the order, specify if the opening is rh or lh; the dividing shelf between the doors is a wooden fixed one; the others are always glass shelves.											
	VOLm <sup>3</sup> Kg										
	0,201 29,5	L. 320	SL1PB2316	<b>459</b>	<b>532</b>	<b>605</b>	<b>636</b>	<b>577</b>	22	78	-
	0,291 37	L. 480	SL1PB2326	<b>522</b>	<b>597</b>	<b>678</b>	<b>722</b>	<b>669</b>	22	78	88
	0,381 46,5	L. 640	SL1PB2336	<b>590</b>	<b>673</b>	<b>766</b>	<b>816</b>	<b>769</b>	22	78	88

Ulteriori combinazioni di aperture e finiture sono possibili utilizzando le scocche vuote a pag. | Additional finishes and opening combinations are possible using the empty bodies on page 93

N.B: L'interno del mobile e del vano a giorno è in materico abbinato per il rovere temottrattato e nodi, in laccato opaco in tinta per i laccati, le superfici UP e per le essenze rovere gesso, visone, cenere e castoro

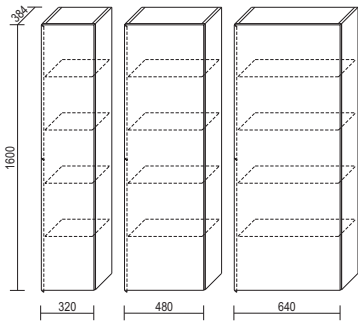
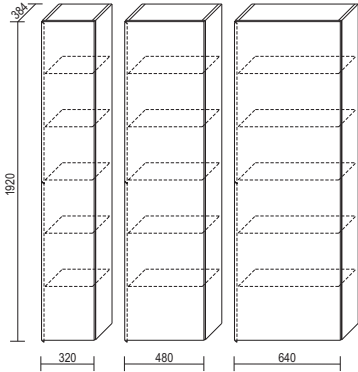
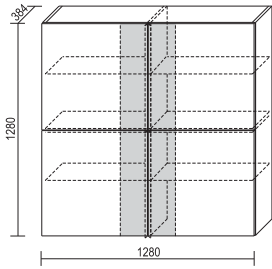
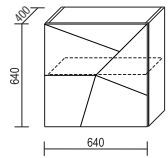
- Aggiungere solo se necessario il top a pag.   Only if necessary, add the top on page 97 - Apertura standard "push and pull"   Standard 'push and pull' opening - Specificare nell'ordine se a terra o sospesi   In the order, specify whether positioned free-standing or supported				codice code	lacc. opaco matt lacq.	essenza cat. 1 wood cat. 1	essenza cat. 2 wood cat. 2	rovere lacc. matt lacq. oak	lacc. lucido glossy lacq.	maniglia Slim	maniglia gola	maniglia XL	
									superfici UP UP surface	Slim handle	Groove handle	XL handle	
<p>Pensile con 1 anta specificare nell'ordine se apertura dx o sx; sempre ripiani vetro dietro l'anta Wall unit with 1 door, in the order, specify if the opening is rh or lh; always glass shelves behind the door</p>  <p>VOLm<sup>3</sup> Kg</p>													
				L. 320	SL1PBL317	496	581	658	696	634	27	58	-
				L. 480	SL1PBL327	561	655	742	787	728	27	58	-
				L. 640	SL1PBL337	636	740	842	899	838	27	58	-
<p>Pensile con 1 anta specificare nell'ordine se apertura dx o sx; sempre ripiani vetro dietro l'anta Wall unit with 1 door, in the order, specify if the opening is rh or lh; always glass shelves behind the door</p>  <p>VOLm<sup>3</sup> Kg</p>													
				L. 320	SL1PBL318	568	664	752	795	730	33	64	-
				L. 480	SL1PBL328	640	749	848	902	836	33	64	-
				L. 640	SL1PBL338	723	845	959	1.025	956	33	64	-
<p>Pensile con 4 ante, il ripiano di divisione tra le ante è fisso in legno, gli altri sono sempre vetro Wall unit with 4 doors, the dividing shelf between the doors is a wooden fixed one; the others are always glass shelves.</p>  <p>Per abbinamenti di maniglie tra loro diverse (Gola+XL) vedi scocche vuote. For different handle combinations (Groove+XL), see the empty bodies.</p> <p>VOLm<sup>3</sup> Kg</p>													
				L. 1280	SL1PB2366	1.066	1.176	1.339	1.421	1.350	44	156	176
<p>Pensile con 1 anta CONCRETE specificare nell'ordine se apertura dx o sx; sempre ripiano vetro dietro l'anta Wall unit with 1 CONCRETE door, in the order, specify if the opening is rh or lh; always glass shelf behind the door</p>  <p>VOLm<sup>3</sup> Kg</p>													
				L. 640	SL1PBC333	600				eff. resina resin effect f.			
										706			

Ulteriori combinazioni di aperture e finiture sono possibili utilizzando le scocche vuote a pag. | Additional finishes and opening combinations are possible using the empty bodies on page 93

# PENSILI ANTA BATTENTE A TERRA O SOSPESI | FREE-STANDING OR SUSPENDED HINGED-DOOR WALL UNITS P. | D. 384

N.B: The interior of the cabinet and open compartment has matching textured f. for heat-treated oak and oak knots finishes and matching matte lacquer for lacquers, UP surfaces, in addition to oak gesso, oak visone, oak cenere and oak castoro woods.

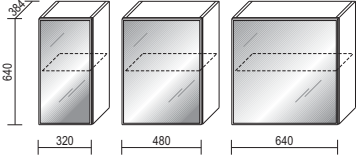
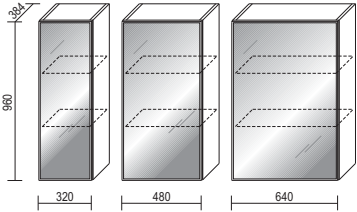
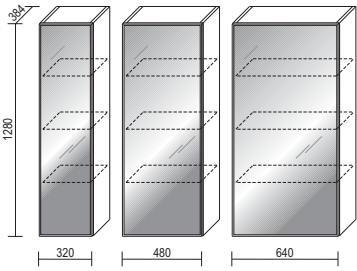
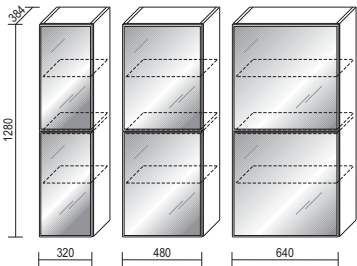
- Aggiungere solo se necessario il top a pag.   Only if necessary, add the top on page 97 - Solo apertura "push and pull"   Only "Push and pull" opening - Specificare nell'ordine se a terra o sospesi   In the order, specify whether positioned free-standing or supported		codice code	lacc. opaco matt lacq.	essenza cat. 1 wood cat. 1	essenza cat. 2 wood cat. 2	rovere lacc. matt lacq. oak	lacc. lucido glossy lacq.	superfici UP UP surface
<p>Pensile con 1 anta vetro SLIM specificare nell'ordine se apertura dx o sx; sempre ripiano vetro dietro l'anta Wall unit with 1 SLIM glass door in the order, specify if the opening is rh or lh; always glass shelf behind the door</p> 								
VOLm <sup>3</sup> Kg								
0,104 17		L. 320 vetro   glass (cat 1)	SL1PBV313	<b>351</b>	<b>383</b>	<b>413</b>	<b>426</b>	<b>398</b>
		L. 320 vetro   glass (cat 2)	SL1PBV313	<b>376</b>	<b>408</b>	<b>438</b>	<b>451</b>	<b>423</b>
0,150 21		L. 480 vetro   glass (cat 1)	SL1PBV323	<b>404</b>	<b>436</b>	<b>468</b>	<b>483</b>	<b>460</b>
		L. 480 vetro   glass (cat 2)	SL1PBV323	<b>439</b>	<b>471</b>	<b>503</b>	<b>518</b>	<b>495</b>
0,196 26,5		L. 640 vetro   glass (cat 1)	SL1PBV333	<b>458</b>	<b>487</b>	<b>523</b>	<b>540</b>	<b>524</b>
		L. 640 vetro   glass (cat 2)	SL1PBV333	<b>504</b>	<b>533</b>	<b>569</b>	<b>586</b>	<b>570</b>
<p>Pensile con 1 anta vetro SLIM specificare nell'ordine se apertura dx o sx; sempre ripiani vetro dietro l'anta Wall unit with 1 SLIM glass door in the order, specify if the opening is rh or lh; always glass shelves behind the door</p> 								
VOLm <sup>3</sup> Kg								
0,153 19,5		L. 320 vetro   glass (cat 1)	SL1PBV315	<b>470</b>	<b>505</b>	<b>543</b>	<b>561</b>	<b>535</b>
		L. 320 vetro   glass (cat 2)	SL1PBV315	<b>504</b>	<b>539</b>	<b>577</b>	<b>595</b>	<b>569</b>
0,220 30,5		L. 480 vetro   glass (cat 1)	SL1PBV325	<b>534</b>	<b>567</b>	<b>608</b>	<b>628</b>	<b>606</b>
		L. 480 vetro   glass (cat 2)	SL1PBV325	<b>589</b>	<b>622</b>	<b>663</b>	<b>683</b>	<b>661</b>
0,288 38		L. 640 vetro   glass (cat 1)	SL1PBV335	<b>606</b>	<b>636</b>	<b>681</b>	<b>702</b>	<b>690</b>
		L. 640 vetro   glass (cat 2)	SL1PBV335	<b>684</b>	<b>714</b>	<b>759</b>	<b>780</b>	<b>768</b>
<p>Pensile con 1 anta vetro SLIM specificare nell'ordine se apertura dx o sx; sempre ripiani vetro dietro l'anta Wall unit with 1 SLIM glass door in the order, specify if the opening is rh or lh; always glass shelves behind the door</p> 								
VOLm <sup>3</sup> Kg								
0,201 31		L. 320 vetro   glass (cat 1)	SL1PBV316	<b>589</b>	<b>625</b>	<b>672</b>	<b>694</b>	<b>671</b>
		L. 320 vetro   glass (cat 2)	SL1PBV316	<b>630</b>	<b>666</b>	<b>713</b>	<b>735</b>	<b>712</b>
0,291 39,5		L. 480 vetro   glass (cat 1)	SL1PBV326	<b>667</b>	<b>701</b>	<b>750</b>	<b>774</b>	<b>754</b>
		L. 480 vetro   glass (cat 2)	SL1PBV326	<b>741</b>	<b>775</b>	<b>824</b>	<b>848</b>	<b>828</b>
0,381 50,5		L. 640 vetro   glass (cat 1)	SL1PBV336	<b>751</b>	<b>783</b>	<b>836</b>	<b>862</b>	<b>853</b>
		L. 640 vetro   glass (cat 2)	SL1PBV336	<b>861</b>	<b>893</b>	<b>946</b>	<b>972</b>	<b>963</b>
<p>Pensile con 2 ante vetro SLIM, specificare nell'ordine se apertura dx o sx; il ripiano di divisione tra le ante è fisso in legno, gli altri sono sempre vetro Wall unit with 2 SLIM glass doors, in the order, specify if the opening is rh or lh; the dividing shelf between the doors is a wooden fixed one; the others are always glass shelves</p> 								
VOLm <sup>3</sup> Kg								
0,201 30,5		L. 320 vetro   glass (cat 1)	SL1PB4316	<b>665</b>	<b>694</b>	<b>741</b>	<b>762</b>	<b>747</b>
		L. 320 vetro   glass (cat 2)	SL1PB4316	<b>715</b>	<b>744</b>	<b>791</b>	<b>812</b>	<b>797</b>
0,291 38,5		L. 480 vetro   glass (cat 1)	SL1PB4326	<b>758</b>	<b>779</b>	<b>828</b>	<b>852</b>	<b>845</b>
		L. 480 vetro   glass (cat 2)	SL1PB4326	<b>828</b>	<b>849</b>	<b>898</b>	<b>922</b>	<b>915</b>
0,381 49		L. 640 vetro   glass (cat 1)	SL1PB4336	<b>858</b>	<b>873</b>	<b>926</b>	<b>952</b>	<b>959</b>
		L. 640 vetro   glass (cat 2)	SL1PB4336	<b>950</b>	<b>965</b>	<b>1.018</b>	<b>1.044</b>	<b>1.051</b>

Ulteriori combinazioni di aperture e finiture sono possibili utilizzando le scocche vuote a pag. | Additional finishes and opening combinations are possible using the empty bodies on page 93



N.B: L'interno del mobile e del vano a giorno è in materico abbinato per il rovere termotrattato e nodi, in laccato opaco in tinta per i laccati, le superfici UP e per le essenze rovere gesso, visone, cenere e castoro

- Aggiungere solo se necessario il top a pag. | Only if necessary, add the top on page 97  
 - Solo apertura "push and pull" | Only "Push and pull" opening  
 - Specificare nell'ordine se a terra o sospesi | In the order, specify whether positioned free-standing or supported

codice code	lacc. opaco matt lacq.	essenza cat. 1 wood cat. 1	essenza cat. 2 wood cat. 2	rovere lacc. matt lacq. oak	lacc. lucido glossy lacq.	superfici UP UP surface
----------------	---------------------------	-------------------------------	-------------------------------	--------------------------------	------------------------------	----------------------------

Pensile con 1 anta vetro SLIM  
 specificare nell'ordine se apertura dx o sx; sempre ripiani vetro dietro l'anta  
 Wall unit with 1 SLIM glass door  
 in the order, specify if the opening is rh or lh; always glass shelves behind the door

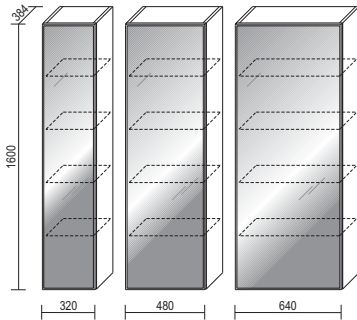

VOLm³ Kg

0,250 38

0,362 49

0,473 62

L. 320 vetro   glass (cat 1)	SL1PBV317	681	723	775	801	776
L. 320 vetro   glass (cat 2)	SL1PBV317	737	779	831	857	832
L. 480 vetro   glass (cat 1)	SL1PBV327	769	804	859	887	870
L. 480 vetro   glass (cat 2)	SL1PBV327	862	897	952	980	963
L. 640 vetro   glass (cat 1)	SL1PBV337	870	900	961	991	983
L. 640 vetro   glass (cat 2)	SL1PBV337	998	1.028	1.089	1.119	1.111

Pensile con 1 anta vetro SLIM  
 specificare nell'ordine se apertura dx o sx; sempre ripiani vetro dietro l'anta  
 Wall unit with 1 SLIM glass door  
 in the order, specify if the opening is rh or lh; always glass shelves behind the door

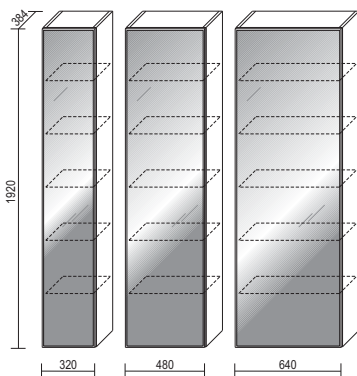

VOLm³ Kg

0,299 45

0,432 58

0,565 73,5

L. 320 vetro   glass (cat 1)	SL1PBV318	772	817	876	906	880
L. 320 vetro   glass (cat 2)	SL1PBV318	843	888	947	977	951
L. 480 vetro   glass (cat 1)	SL1PBV328	873	910	972	1.004	988
L. 480 vetro   glass (cat 2)	SL1PBV328	981	1.018	1.080	1.112	1.096
L. 640 vetro   glass (cat 1)	SL1PBV338	985	1.016	1.083	1.118	1.113
L. 640 vetro   glass (cat 2)	SL1PBV338	1.131	1.162	1.229	1.264	1.259

Pensile con 4 ante vetro SLIM  
 il ripiano di divisione tra le ante è fisso in legno, gli altri sono sempre vetro  
 Wall unit with 4 SLIM glass doors  
 the dividing shelf between the doors is a wooden fixed one; the others are always glass shelves

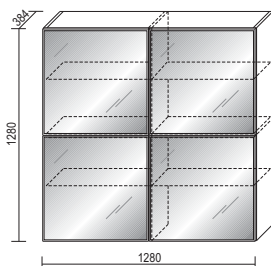

VOLm³ Kg

0,739 84

L. 1280 vetro   glass (cat 1)	SL1PB4366	1.602	1.576	1.659	1.693	1.730
L. 1280 vetro   glass (cat 2)	SL1PB4366	1.786	1.760	1.843	1.877	1.914

Ulteriori combinazioni di aperture e finiture sono possibili utilizzando le scocche vuote a pag. | Additional finishes and opening combinations are possible using the empty bodies on page 93

# PENSILI ANTA BATTENTE A TERRA O SOSPESI | FREE-STANDING OR SUSPENDED HINGED-DOOR WALL UNITS P. | D. 397

N.B: The interior of the cabinet and open compartment has matching textured f. for heat-treated oak and oak knots finishes and matching matte lacquer for lacquers, UP surfaces, in addition to oak gesso, oak visone, oak cenere and oak castoro woods.

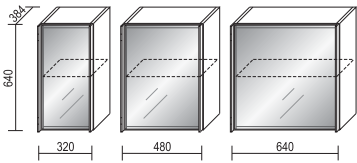
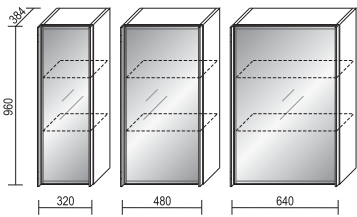
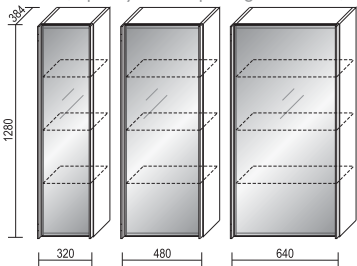
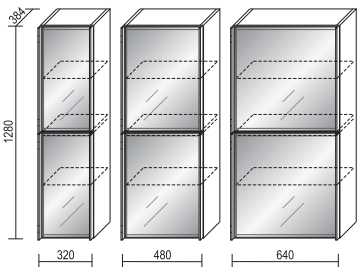
- Ante vetro UP: sono utilizzabili esclusivamente su pensili senza l'impiego di top - Apertura tramite presa laterale sul telaio dell'anta, sono disponibili solo in vetro trasparente grigio - Specificare nell'ordine se a terra o sospesi   In the order, specify whether positioned free-standing or supported - UP glass doors: they can only be used on wall units with no tops - Side grip opening on the glass door frame. Only available in a grey transparent glass.		codice code	lacc. opaco matt lacq.	essenza cat. 1 wood cat. 1	essenza cat. 2 wood cat. 2	rovere lacc. matt lacq. oak	lacc. lucido glossy lacq.	superfici UP UP surface
<b>Pensile con 1 anta vetro UP</b> specificare nell'ordine se apertura dx o sx; sempre ripiano vetro dietro l'anta Wall unit with 1 UP glass door in the order, specify if the opening is rh or lh; always glass shelf behind the door								
								
VOL.m <sup>3</sup> Kg vetro trasparente grigio grey transparent glass								
0,104 17 L. 320		SL1PBU313	<b>473</b>	<b>505</b>	<b>535</b>	<b>548</b>	<b>520</b>	
0,150 21 L. 480		SL1PBU323	<b>516</b>	<b>548</b>	<b>580</b>	<b>595</b>	<b>572</b>	
0,196 26,5 L. 640		SL1PBU333	<b>562</b>	<b>591</b>	<b>627</b>	<b>644</b>	<b>628</b>	
<b>Pensile con 1 anta vetro UP</b> specificare nell'ordine se apertura dx o sx; sempre ripiani vetro dietro l'anta Wall unit with 1 UP glass door in the order, specify if the opening is rh or lh; always glass shelves behind the door								
								
VOL.m <sup>3</sup> Kg vetro trasparente grigio grey transparent glass								
0,153 19,5 L. 320		SL1PBU315	<b>575</b>	<b>610</b>	<b>648</b>	<b>666</b>	<b>640</b>	
0,220 30,5 L. 480		SL1PBU325	<b>631</b>	<b>664</b>	<b>705</b>	<b>725</b>	<b>703</b>	
0,288 38 L. 640		SL1PBU335	<b>690</b>	<b>720</b>	<b>765</b>	<b>786</b>	<b>774</b>	
<b>Pensile con 1 anta vetro UP</b> specificare nell'ordine se apertura dx o sx; sempre ripiani vetro dietro l'anta Wall unit with 1 UP glass door in the order, specify if the opening is rh or lh; always glass shelves behind the door								
								
VOL.m <sup>3</sup> Kg vetro trasparente grigio grey transparent glass								
0,201 31 L. 320		SL1PBU316	<b>676</b>	<b>712</b>	<b>759</b>	<b>781</b>	<b>758</b>	
0,291 39,5 L. 480		SL1PBU326	<b>741</b>	<b>775</b>	<b>824</b>	<b>848</b>	<b>828</b>	
0,381 50,5 L. 640		SL1PBU336	<b>817</b>	<b>849</b>	<b>902</b>	<b>928</b>	<b>919</b>	
<b>Pensile con 2 ante vetro UP</b> , specificare nell'ordine se apertura dx o sx; il ripiano di divisione tra le ante è fisso in legno, gli altri sono sempre vetro Wall unit with 2 UP glass doors, in the order, specify if the opening is rh or lh; the dividing shelf between the doors is a wooden fixed one; the others are always glass shelves								
								
VOL.m <sup>3</sup> Kg vetro trasparente grigio grey transparent glass								
0,201 30,5 L. 320		SL1PB6316	<b>909</b>	<b>938</b>	<b>985</b>	<b>1.006</b>	<b>991</b>	
0,291 38,5 L. 480		SL1PB6326	<b>982</b>	<b>1.003</b>	<b>1.052</b>	<b>1.076</b>	<b>1.069</b>	
0,381 49 L. 640		SL1PB6336	<b>1.066</b>	<b>1.081</b>	<b>1.134</b>	<b>1.160</b>	<b>1.167</b>	

N.B: L'interno del mobile e del vano a giorno è in materico abbinato per il rovere temottrattato e nodi, in laccato opaco in tinta per i laccati, le superfici UP e per le essenze rovere gesso, visone, cenere e castoro

- Ante vetro UP: sono utilizzabili esclusivamente su pensili senza l'impiego di top
- Apertura tramite presa laterale sul telaio dell'anta, sono disponibili solo in vetro trasparente grigio
- Specificare nell'ordine se a terra o sospesi | In the order, specify whether positioned free-standing or supported
- UP glass doors: they can only be used on wall units with no tops
- Side grip opening on the glass door frame. Only available in a grey transparent glass.

codice code	lacc. opaco matt lacq.	essenza cat. 1 wood cat. 1	essenza cat. 2 wood cat. 2	rovere lacc. matt lacq. oak	lacc. lucido glossy lacq.	superfici UP UP surface
-------------	------------------------	----------------------------	----------------------------	-----------------------------	---------------------------	-------------------------

Pensile con 1 anta vetro UP  
 specificare nell'ordine se apertura dx o sx; sempre ripiani vetro dietro l'anta  
 Wall unit with 1 UP glass door  
 in the order, specify if the opening is rh or lh; always glass shelves behind the door

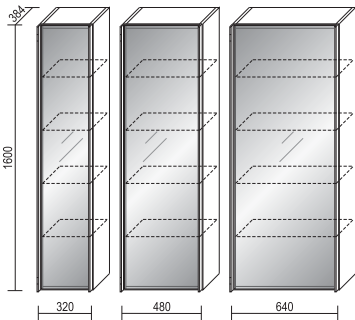

VOL.m³	Kg	vetro trasparente grigio grey transparent glass
0,250	38	L. 320
0,362	49	L. 480
0,473	62	L. 640

SL1PBU317	<b>762</b>	<b>804</b>	<b>856</b>	<b>882</b>	<b>857</b>	
SL1PBU327	<b>839</b>	<b>874</b>	<b>929</b>	<b>957</b>	<b>940</b>	
SL1PBU337	<b>927</b>	<b>957</b>	<b>1.018</b>	<b>1.048</b>	<b>1.040</b>	

Pensile con 1 anta vetro UP  
 specificare nell'ordine se apertura dx o sx; sempre ripiani vetro dietro l'anta  
 Wall unit with 1 UP glass door  
 in the order, specify if the opening is rh or lh; always glass shelves behind the door

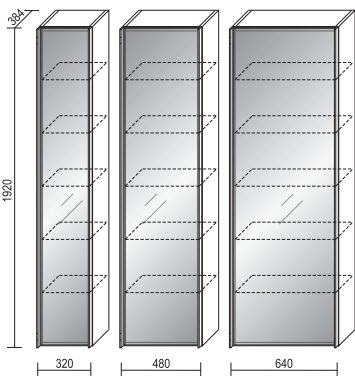

VOL.m³	Kg	vetro trasparente grigio grey transparent glass
0,299	45	L. 320
0,432	58	L. 480
0,565	73,5	L. 640

SL1PBU318	<b>861</b>	<b>906</b>	<b>965</b>	<b>995</b>	<b>969</b>	
SL1PBU328	<b>947</b>	<b>984</b>	<b>1.046</b>	<b>1.078</b>	<b>1.062</b>	
SL1PBU338	<b>1.046</b>	<b>1.077</b>	<b>1.144</b>	<b>1.179</b>	<b>1.174</b>	

Pensile con 4 ante vetro UP  
 il ripiano di divisione tra le ante è fisso in legno, gli altri sono sempre vetro  
 Wall unit with 4 UP glass doors  
 the dividing shelf between the doors is a wooden fixed one; the others are always glass shelves

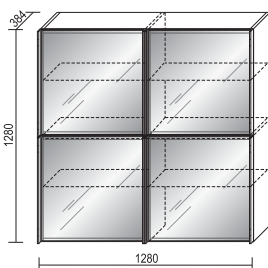

VOL.m³	Kg	vetro trasparente grigio grey transparent glass
0,739	84	L. 1280

SL1PB6366	<b>2.018</b>	<b>1.992</b>	<b>2.075</b>	<b>2.109</b>	<b>2.146</b>	
-----------	--------------	--------------	--------------	--------------	--------------	--

# PENSILI ANTA BATTENTE A TERRA O SOSPESI | FREE-STANDING OR SUSPENDED HINGED-DOOR WALL UNITS P. | D. 480

N.B: The interior of the cabinet and open compartment has matching textured f. for heat-treated oak and oak knots finishes and matching matte lacquer for lacquers, UP surfaces, in addition to oak gesso, oak visone, oak cenere and oak castoro woods.

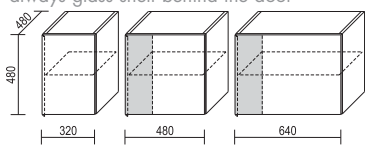
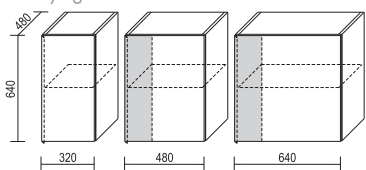
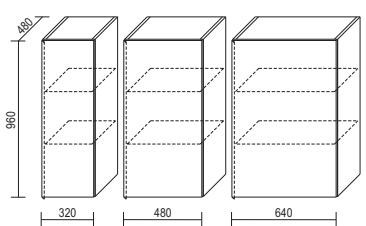
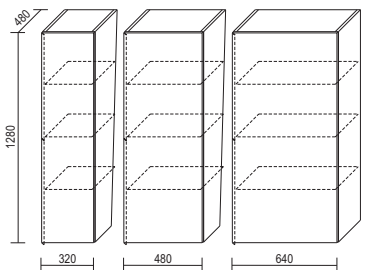
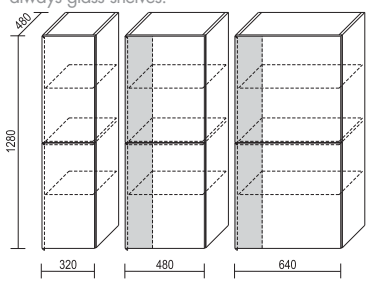
- Aggiungere solo se necessario il top a pag.   Only if necessary, add the top on page 97 - Apertura standard "push and pull"   Standard "push and pull" opening - Specificare nell'ordine se a terra o sospesi   In the order, specify whether positioned free-standing or supported		codice code	lacc. opaco matt lacq.	essenza cat. 1 wood cat. 1	essenza cat. 2 wood cat. 2	rovere lacc. matt lacq. oak	lacc. lucido glossy lacq.	maniglia Slim	maniglia gola Groove	maniglia XL	
							superfici UP UP surface	Slim handle	Groove handle	XL handle	
<b>Pensile con 1 anta</b> specificare nell'ordine se apertura dx o sx; sempre ripiano vetro dietro l'anta Wall unit with 1 door, in the order, specify if the opening is rh or lh; always glass shelf behind the door 		VOLm <sup>3</sup> Kg									
	0,097 13,5	L. 320	SL1PBL412	234	283	324	340	296	10	37	-
	0,141 18	L. 480	SL1PBL422	272	325	369	391	349	10	37	38
	0,184 21	L. 640	SL1PBL432	306	361	411	437	399	10	37	38
<b>Pensile con 1 anta</b> specificare nell'ordine se apertura dx o sx; sempre ripiano vetro dietro l'anta Wall unit with 1 door, in the order, specify if the opening is rh or lh; always glass shelf behind the door 		VOLm <sup>3</sup> Kg									
	0,134 18	L. 320	SL1PBL413	264	321	368	387	334	11	39	-
	0,194 24	L. 480	SL1PBL423	305	367	418	445	397	11	39	44
	0,254 28	L. 640	SL1PBL433	346	412	470	501	457	11	39	44
<b>Pensile con 1 anta</b> specificare nell'ordine se apertura dx o sx; sempre ripiani vetro dietro l'anta Wall unit with 1 door, in the order, specify if the opening is rh or lh; always glass shelves behind the door 		VOLm <sup>3</sup> Kg									
	0,194 27	L. 320	SL1PBL415	357	423	482	507	455	17	46	-
	0,280 34	L. 480	SL1PBL425	406	482	547	580	525	17	46	-
	0,367 41	L. 640	SL1PBL435	464	545	620	661	611	17	46	-
<b>Pensile con 1 anta</b> specificare nell'ordine se apertura dx o sx; sempre ripiani vetro dietro l'anta Wall unit with 1 door, in the order, specify if the opening is rh or lh; always glass shelves behind the door 		VOLm <sup>3</sup> Kg									
	0,254 35	L. 320	SL1PBL416	451	526	597	629	573	21	51	-
	0,367 45	L. 480	SL1PBL426	509	593	675	714	659	21	51	-
	0,480 54	L. 640	SL1PBL436	582	677	769	818	763	21	51	-
<b>Pensile con 2 ante, specificare nell'ordine se apertura dx o sx; il ripiano di divisione tra le ante è fisso in legno, gli altri sono sempre vetro</b> Wall unit with 2 doors, in the order, specify if the opening is rh or lh; the dividing shelf between the doors is a wooden fixed one; the others are always glass shelves. 		VOLm <sup>3</sup> Kg									
	0,254 34	L. 320	SL1PB2416	494	565	641	674	618	22	78	-
	0,367 44	L. 480	SL1PB2426	557	632	718	762	712	22	78	88
	0,480 52	L. 640	SL1PB2436	632	712	810	861	821	22	78	88

Ulteriori combinazioni di aperture e finiture sono possibili utilizzando le scocche vuote a pag. | Additional finishes and opening combinations are possible using the empty bodies on page 93

**PENSILI ANTA BATTENTE A TERRA O SOSPESI | FREE-STANDING OR SUSPENDED HINGED-DOOR WALL UNITS** P. | D. 480

N.B: L'interno del mobile e del vano a giorno è in materico abbinato per il rovere temottrattato e nodi, in laccato opaco in tinta per i laccati, le superfici UP e per le essenze rovere gesso, visone, cenere e castoro

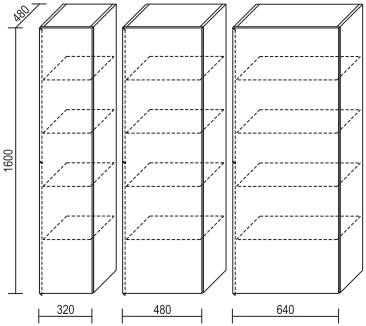
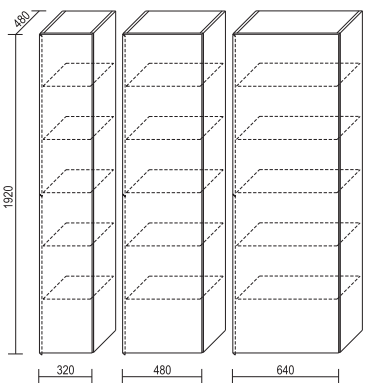
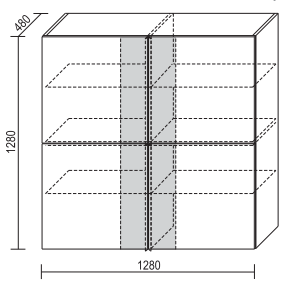
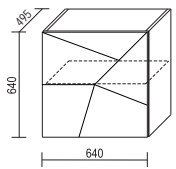
- Aggiungere solo se necessario il top a pag.   Only if necessary, add the top on page 97 - Apertura standard "push and pull"   Standard 'push and pull' opening - Specificare nell'ordine se a terra o sospesi   In the order, specify whether positioned free-standing or supported		codice code	lacc. opaco matt lacq.	essenza cat. 1 wood cat. 1	essenza cat. 2 wood cat. 2	rovere lacc. matt lacq. oak	lacc. lucido glossy lacq.	maniglia Slim	maniglia gola Groove	maniglia XL																																				
							superfici UP UP surface	Slim handle	Groove handle	XL handle																																				
<p><b>Pensile con 1 anta</b> specificare nell'ordine se apertura dx o sx; sempre ripiani vetro dietro l'anta Wall unit with 1 door, in the order, specify if the opening is rh or lh; always glass shelves behind the door</p>  <p>VOLm<sup>3</sup> Kg</p> <table border="1"> <tr> <td>0,318</td> <td>43</td> <td>L. 320</td> <td>SL1PBL417</td> <td><b>529</b></td> <td><b>619</b></td> <td><b>700</b></td> <td><b>739</b></td> <td><b>677</b></td> <td>27</td> <td>58</td> <td>-</td> </tr> <tr> <td>0,459</td> <td>56</td> <td>L. 480</td> <td>SL1PBL427</td> <td><b>596</b></td> <td><b>693</b></td> <td><b>786</b></td> <td><b>832</b></td> <td><b>773</b></td> <td>27</td> <td>58</td> <td>-</td> </tr> <tr> <td>0,580</td> <td>62</td> <td>L. 640</td> <td>SL1PBL437</td> <td><b>681</b></td> <td><b>792</b></td> <td><b>900</b></td> <td><b>959</b></td> <td><b>895</b></td> <td>27</td> <td>58</td> <td>-</td> </tr> </table>											0,318	43	L. 320	SL1PBL417	<b>529</b>	<b>619</b>	<b>700</b>	<b>739</b>	<b>677</b>	27	58	-	0,459	56	L. 480	SL1PBL427	<b>596</b>	<b>693</b>	<b>786</b>	<b>832</b>	<b>773</b>	27	58	-	0,580	62	L. 640	SL1PBL437	<b>681</b>	<b>792</b>	<b>900</b>	<b>959</b>	<b>895</b>	27	58	-
0,318	43	L. 320	SL1PBL417	<b>529</b>	<b>619</b>	<b>700</b>	<b>739</b>	<b>677</b>	27	58	-																																			
0,459	56	L. 480	SL1PBL427	<b>596</b>	<b>693</b>	<b>786</b>	<b>832</b>	<b>773</b>	27	58	-																																			
0,580	62	L. 640	SL1PBL437	<b>681</b>	<b>792</b>	<b>900</b>	<b>959</b>	<b>895</b>	27	58	-																																			
<p><b>Pensile con 1 anta</b> specificare nell'ordine se apertura dx o sx; sempre ripiani vetro dietro l'anta Wall unit with 1 door, in the order, specify if the opening is rh or lh; always glass shelves behind the door</p>  <p>VOLm<sup>3</sup> Kg</p> <table border="1"> <tr> <td>0,383</td> <td>52</td> <td>L. 320</td> <td>SL1PBL418</td> <td><b>608</b></td> <td><b>707</b></td> <td><b>800</b></td> <td><b>845</b></td> <td><b>779</b></td> <td>33</td> <td>64</td> <td>-</td> </tr> <tr> <td>0,554</td> <td>67</td> <td>L. 480</td> <td>SL1PBL428</td> <td><b>682</b></td> <td><b>792</b></td> <td><b>898</b></td> <td><b>953</b></td> <td><b>887</b></td> <td>33</td> <td>64</td> <td>-</td> </tr> <tr> <td>0,693</td> <td>82</td> <td>L. 640</td> <td>SL1PBL438</td> <td><b>776</b></td> <td><b>909</b></td> <td><b>1.031</b></td> <td><b>1.099</b></td> <td><b>1.022</b></td> <td>33</td> <td>64</td> <td>-</td> </tr> </table>											0,383	52	L. 320	SL1PBL418	<b>608</b>	<b>707</b>	<b>800</b>	<b>845</b>	<b>779</b>	33	64	-	0,554	67	L. 480	SL1PBL428	<b>682</b>	<b>792</b>	<b>898</b>	<b>953</b>	<b>887</b>	33	64	-	0,693	82	L. 640	SL1PBL438	<b>776</b>	<b>909</b>	<b>1.031</b>	<b>1.099</b>	<b>1.022</b>	33	64	-
0,383	52	L. 320	SL1PBL418	<b>608</b>	<b>707</b>	<b>800</b>	<b>845</b>	<b>779</b>	33	64	-																																			
0,554	67	L. 480	SL1PBL428	<b>682</b>	<b>792</b>	<b>898</b>	<b>953</b>	<b>887</b>	33	64	-																																			
0,693	82	L. 640	SL1PBL438	<b>776</b>	<b>909</b>	<b>1.031</b>	<b>1.099</b>	<b>1.022</b>	33	64	-																																			
<p><b>Pensile con 4 ante</b> il ripiano di divisione tra le ante è fisso in legno, gli altri sono sempre vetro Wall unit with 4 doors, the dividing shelf between the doors is a wooden fixed one; the others are always glass shelves</p>  <p>Per abbinamenti di maniglie tra loro diverse (Gola+XL) vedi scocche vuote. For different handle combinations (Groove+XL), see the empty bodies.</p> <p>VOLm<sup>3</sup> Kg</p> <table border="1"> <tr> <td>0,927</td> <td>102</td> <td>L. 1280</td> <td>SL1PB2466</td> <td><b>1.132</b></td> <td><b>1.241</b></td> <td><b>1.411</b></td> <td><b>1.494</b></td> <td><b>1.429</b></td> <td>44</td> <td>156</td> <td>176</td> </tr> </table>											0,927	102	L. 1280	SL1PB2466	<b>1.132</b>	<b>1.241</b>	<b>1.411</b>	<b>1.494</b>	<b>1.429</b>	44	156	176																								
0,927	102	L. 1280	SL1PB2466	<b>1.132</b>	<b>1.241</b>	<b>1.411</b>	<b>1.494</b>	<b>1.429</b>	44	156	176																																			
<p><b>Pensile con 1 anta CONCRETE</b> specificare nell'ordine se apertura dx o sx; sempre ripiano vetro dietro l'anta Wall unit with 1 CONCRETE door, in the order, specify if the opening is rh or lh; always glass shelf behind the door</p>  <p>VOLm<sup>3</sup> Kg</p> <table border="1"> <tr> <td>0,247</td> <td>31</td> <td>L. 640</td> <td>SL1PBC433</td> <td><b>622</b></td> <td></td> <td></td> <td></td> <td><b>eff. resina resin effect f.</b> <b>734</b></td> <td></td> <td></td> <td></td> </tr> </table>											0,247	31	L. 640	SL1PBC433	<b>622</b>				<b>eff. resina resin effect f.</b> <b>734</b>																											
0,247	31	L. 640	SL1PBC433	<b>622</b>				<b>eff. resina resin effect f.</b> <b>734</b>																																						

Ulteriori combinazioni di aperture e finiture sono possibili utilizzando le scocche vuote a pag. | Additional finishes and opening combinations are possible using the empty bodies on page 93

# PENSILI ANTA BATTENTE A TERRA O SOSPESI | FREE-STANDING OR SUSPENDED HINGED-DOOR WALL UNITS P. | D. 480

N.B: The interior of the cabinet and open compartment has matching textured f. for heat-treated oak and oak knots finishes and matching matte lacquer for lacquers, UP surfaces, in addition to oak gesso, oak visone, oak cenere and oak castoro woods.

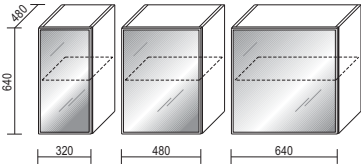
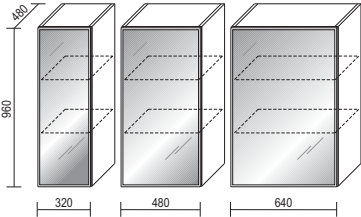
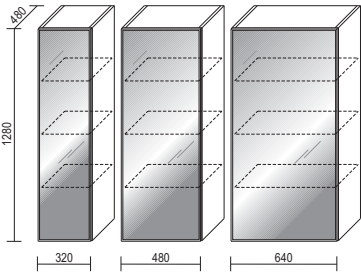
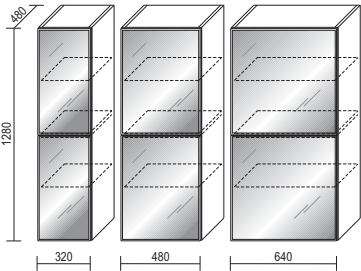
- Aggiungere solo se necessario il top a pag.   Only if necessary, add the top on page 97 - Solo apertura "push and pull"   Only "Push and pull" opening - Specificare nell'ordine se a terra o sospesi   In the order, specify whether positioned free-standing or supported		codice code	lacc. opaco matt lacq.	essenza cat. 1 wood cat. 1	essenza cat. 2 wood cat. 2	rovere lacc. matt lacq. oak	lacc. lucido glossy lacq.	superfici UP UP surface
<p>Pensile con 1 anta vetro SLIM specificare nell'ordine se apertura dx o sx; sempre ripiano vetro dietro l'anta Wall unit with 1 SLIM glass door in the order, specify if the opening is rh or lh; always glass shelf behind the door</p>								
	VOLm <sup>3</sup> Kg							
	0,134 19	L. 320 vetro   glass (cat 1)	SL1PBV413	<b>367</b>	<b>402</b>	<b>436</b>	<b>450</b>	<b>419</b>
		L. 320 vetro   glass (cat 2)	SL1PBV413	<b>392</b>	<b>427</b>	<b>461</b>	<b>475</b>	<b>444</b>
	0,194 25	L. 480 vetro   glass (cat 1)	SL1PBV423	<b>423</b>	<b>458</b>	<b>493</b>	<b>510</b>	<b>485</b>
		L. 480 vetro   glass (cat 2)	SL1PBV423	<b>458</b>	<b>493</b>	<b>528</b>	<b>545</b>	<b>520</b>
	0,254 29	L. 640 vetro   glass (cat 1)	SL1PBV433	<b>480</b>	<b>512</b>	<b>550</b>	<b>569</b>	<b>552</b>
	L. 640 vetro   glass (cat 2)	SL1PBV433	<b>526</b>	<b>558</b>	<b>596</b>	<b>615</b>	<b>598</b>	
<p>Pensile con 1 anta vetro SLIM specificare nell'ordine se apertura dx o sx; sempre ripiani vetro dietro l'anta Wall unit with 1 SLIM glass door in the order, specify if the opening is rh or lh; always glass shelves behind the door</p>								
	VOLm <sup>3</sup> Kg							
	0,194 28	L. 320 vetro   glass (cat 1)	SL1PBV415	<b>493</b>	<b>531</b>	<b>572</b>	<b>591</b>	<b>564</b>
		L. 320 vetro   glass (cat 2)	SL1PBV415	<b>527</b>	<b>565</b>	<b>606</b>	<b>625</b>	<b>598</b>
	0,280 35	L. 480 vetro   glass (cat 1)	SL1PBV425	<b>558</b>	<b>595</b>	<b>639</b>	<b>660</b>	<b>637</b>
		L. 480 vetro   glass (cat 2)	SL1PBV425	<b>613</b>	<b>650</b>	<b>694</b>	<b>715</b>	<b>692</b>
	0,367 42	L. 640 vetro   glass (cat 1)	SL1PBV435	<b>636</b>	<b>668</b>	<b>717</b>	<b>740</b>	<b>728</b>
	L. 640 vetro   glass (cat 2)	SL1PBV435	<b>714</b>	<b>746</b>	<b>795</b>	<b>818</b>	<b>806</b>	
<p>Pensile con 1 anta vetro SLIM specificare nell'ordine se apertura dx o sx; sempre ripiani vetro dietro l'anta Wall unit with 1 SLIM glass door in the order, specify if the opening is rh or lh; always glass shelves behind the door</p>								
	VOLm <sup>3</sup> Kg							
	0,254 36	L. 320 vetro   glass (cat 1)	SL1PBV416	<b>618</b>	<b>657</b>	<b>707</b>	<b>730</b>	<b>706</b>
		L. 320 vetro   glass (cat 2)	SL1PBV416	<b>659</b>	<b>698</b>	<b>748</b>	<b>771</b>	<b>747</b>
	0,367 46	L. 480 vetro   glass (cat 1)	SL1PBV426	<b>698</b>	<b>735</b>	<b>789</b>	<b>813</b>	<b>794</b>
		L. 480 vetro   glass (cat 2)	SL1PBV426	<b>772</b>	<b>809</b>	<b>863</b>	<b>887</b>	<b>868</b>
	0,480 55	L. 640 vetro   glass (cat 1)	SL1PBV436	<b>789</b>	<b>822</b>	<b>880</b>	<b>907</b>	<b>899</b>
	L. 640 vetro   glass (cat 2)	SL1PBV436	<b>899</b>	<b>932</b>	<b>990</b>	<b>1.017</b>	<b>1.009</b>	
<p>Pensile con 2 ante vetro SLIM, specificare nell'ordine se apertura dx o sx; il ripiano di divisione tra le ante è fisso in legno, gli altri sono sempre vetro Wall unit with 2 SLIM glass doors, in the order, specify if the opening is rh or lh; the dividing shelf between the doors is a wooden fixed one; the others are always glass shelves</p>								
	VOLm <sup>3</sup> Kg							
	0,254 35	L. 320 vetro   glass (cat 1)	SL1PB4416	<b>700</b>	<b>727</b>	<b>777</b>	<b>800</b>	<b>788</b>
		L. 320 vetro   glass (cat 2)	SL1PB4416	<b>750</b>	<b>777</b>	<b>827</b>	<b>850</b>	<b>838</b>
	0,367 45	L. 480 vetro   glass (cat 1)	SL1PB4426	<b>793</b>	<b>814</b>	<b>868</b>	<b>892</b>	<b>888</b>
		L. 480 vetro   glass (cat 2)	SL1PB4426	<b>863</b>	<b>884</b>	<b>938</b>	<b>962</b>	<b>958</b>
	0,480 53	L. 640 vetro   glass (cat 1)	SL1PB4436	<b>900</b>	<b>912</b>	<b>970</b>	<b>997</b>	<b>1.011</b>
	L. 640 vetro   glass (cat 2)	SL1PB4436	<b>992</b>	<b>1.004</b>	<b>1.062</b>	<b>1.089</b>	<b>1.103</b>	

Ulteriori combinazioni di aperture e finiture sono possibili utilizzando le scocche vuote a pag. | Additional finishes and opening combinations are possible using the empty bodies on page 93

N.B: L'interno del mobile e del vano a giorno è in materico abbinato per il rovere termotrattato e nodi, in laccato opaco in tinta per i laccati, le superfici UP e per le essenze rovere gesso, visone, cenere e castoro

- Aggiungere solo se necessario il top a pag. | Only if necessary, add the top on page 97  
 - Solo apertura "push and pull" | Only "Push and pull" opening  
 - Specificare nell'ordine se a terra o sospesi | In the order, specify whether positioned free-standing or supported

codice code	lacc. opaco matt lacq.	essenza cat. 1 wood cat. 1	essenza cat. 2 wood cat. 2	rovere lacc. matt lacq. oak	lacc. lucido glossy lacq.	superfici UP UP surface
----------------	---------------------------	-------------------------------	-------------------------------	--------------------------------	------------------------------	----------------------------

Pensile con 1 anta vetro SLIM  
 specificare nell'ordine se apertura dx o sx; sempre ripiani vetro dietro l'anta  
 Wall unit with 1 SLIM glass door  
 in the order, specify if the opening is rh or lh; always glass shelves behind the door

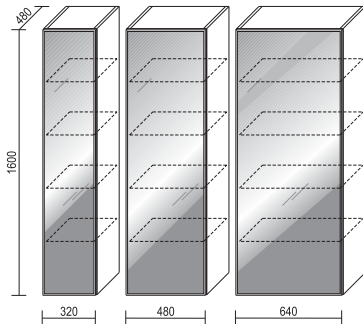

VOLm³ Kg

0,318 44

0,459 57

0,580 63

L. 320 vetro   glass (cat 1)	SL1PBV417	714	761	817	844	819
L. 320 vetro   glass (cat 2)	SL1PBV417	770	817	873	900	875
L. 480 vetro   glass (cat 1)	SL1PBV427	804	842	903	932	915
L. 480 vetro   glass (cat 2)	SL1PBV427	897	935	996	1.025	1.008
L. 640 vetro   glass (cat 1)	SL1PBV437	915	952	1.019	1.051	1.040
L. 640 vetro   glass (cat 2)	SL1PBV437	1.043	1.080	1.147	1.179	1.168

Pensile con 1 anta vetro SLIM  
 specificare nell'ordine se apertura dx o sx; sempre ripiani vetro dietro l'anta  
 Wall unit with 1 SLIM glass door  
 in the order, specify if the opening is rh or lh; always glass shelves behind the door

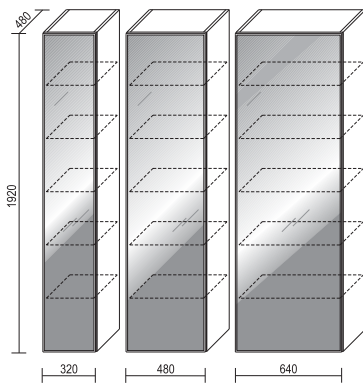

VOLm³ Kg

0,383 53

0,554 68

0,693 83

L. 320 vetro   glass (cat 1)	SL1PBV418	812	860	924	956	929
L. 320 vetro   glass (cat 2)	SL1PBV418	883	931	995	1.027	1.000
L. 480 vetro   glass (cat 1)	SL1PBV428	915	953	1.022	1.055	1.039
L. 480 vetro   glass (cat 2)	SL1PBV428	1.023	1.061	1.130	1.163	1.147
L. 640 vetro   glass (cat 1)	SL1PBV438	1.038	1.080	1.155	1.192	1.179
L. 640 vetro   glass (cat 2)	SL1PBV438	1.184	1.226	1.301	1.338	1.325

Pensile con 4 ante vetro SLIM  
 il ripiano di divisione tra le ante è fisso in legno, gli altri sono sempre vetro  
 Wall unit with 4 SLIM glass doors  
 the dividing shelf between the doors is a wooden fixed one; the others are always glass shelves

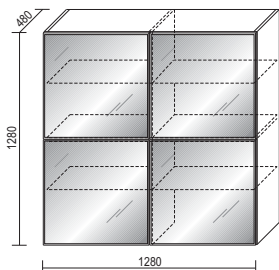

VOLm³ Kg

0,927 104

L. 1280 vetro   glass (cat 1)	SL1PB4466	1.668	1.641	1.731	1.766	1.809
L. 1280 vetro   glass (cat 2)	SL1PB4466	1.852	1.825	1.915	1.950	1.993

Ulteriori combinazioni di aperture e finiture sono possibili utilizzando le scocche vuote a pag. | Additional finishes and opening combinations are possible using the empty bodies on page 93



# PENSILI ANTA BATTENTE A TERRA O SOSPESI | FREE-STANDING OR SUSPENDED HINGED-DOOR WALL UNITS P. | D. 493

N.B: The interior of the cabinet and open compartment has matching textured f. for heat-treated oak and oak knots finishes and matching matte lacquer for lacquers, UP surfaces, in addition to oak gesso, oak visone, oak cenere and oak castoro woods.

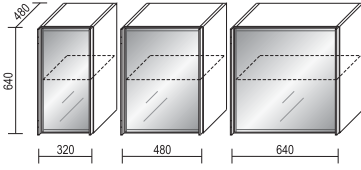
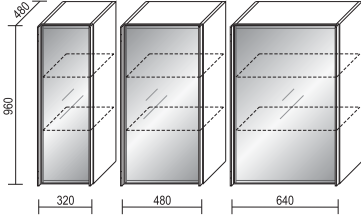
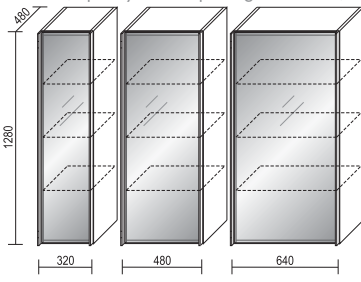
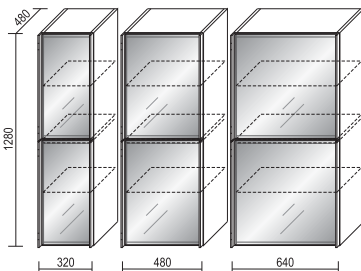
- Ante vetro UP: sono utilizzabili esclusivamente su pensili senza l'impiego di top - Apertura tramite presa laterale sul telaio dell'anta, sono disponibili solo in vetro trasparente grigio - Specificare nell'ordine se a terra o sospesi   In the order, specify whether positioned free-standing or supported - UP glass doors: they can only be used on wall units with no tops - Side grip opening on the glass door frame. Only available in a grey transparent glass.		codice code	lacc. opaco matt lacq.	essenza cat. 1 wood cat. 1	essenza cat. 2 wood cat. 2	rovere lacc. matt lacq. oak	lacc. lucido glossy lacq.	superfici UP UP surface
<b>Pensile con 1 anta vetro UP</b> specificare nell'ordine se apertura dx o sx; sempre ripiano vetro dietro l'anta Wall unit with 1 UP glass door in the order, specify if the opening is rh or lh; always glass shelf behind the door								
	VOL.m <sup>3</sup> Kg	vetro trasparente grigio grey transparent glass						
	0,134 19	L. 320	SL1PBU413	<b>489</b>	<b>524</b>	<b>558</b>	<b>572</b>	<b>541</b>
	0,194 25	L. 480	SL1PBU423	<b>535</b>	<b>570</b>	<b>605</b>	<b>622</b>	<b>597</b>
0,254 29	L. 640	SL1PBU433	<b>584</b>	<b>616</b>	<b>654</b>	<b>673</b>	<b>656</b>	
<b>Pensile con 1 anta vetro UP</b> specificare nell'ordine se apertura dx o sx; sempre ripiani vetro dietro l'anta Wall unit with 1 UP glass door in the order, specify if the opening is rh or lh; always glass shelves behind the door								
	VOL.m <sup>3</sup> Kg	vetro trasparente grigio grey transparent glass						
	0,194 28	L. 320	SL1PBU415	<b>598</b>	<b>636</b>	<b>677</b>	<b>696</b>	<b>669</b>
	0,280 35	L. 480	SL1PBU425	<b>655</b>	<b>692</b>	<b>736</b>	<b>757</b>	<b>734</b>
0,367 42	L. 640	SL1PBU435	<b>720</b>	<b>752</b>	<b>801</b>	<b>824</b>	<b>812</b>	
<b>Pensile con 1 anta vetro UP</b> specificare nell'ordine se apertura dx o sx; sempre ripiani vetro dietro l'anta Wall unit with 1 UP glass door in the order, specify if the opening is rh or lh; always glass shelves behind the door								
	VOL.m <sup>3</sup> Kg	vetro trasparente grigio grey transparent glass						
	0,254 36	L. 320	SL1PBU416	<b>705</b>	<b>744</b>	<b>794</b>	<b>817</b>	<b>793</b>
	0,367 46	L. 480	SL1PBU426	<b>772</b>	<b>809</b>	<b>863</b>	<b>887</b>	<b>868</b>
0,480 55	L. 640	SL1PBU436	<b>855</b>	<b>888</b>	<b>946</b>	<b>973</b>	<b>965</b>	
<b>Pensile con 2 ante vetro UP</b> , specificare nell'ordine se apertura dx o sx; il ripiano di divisione tra le ante è fisso in legno, gli altri sono sempre vetro Wall unit with 2 UP glass doors, in the order, specify if the opening is rh or lh; the dividing shelf between the doors is a wooden fixed one; the others are always glass shelves								
	VOL.m <sup>3</sup> Kg	vetro trasparente grigio grey transparent glass						
	0,254 35	L. 320	SL1PB6416	<b>944</b>	<b>971</b>	<b>1.021</b>	<b>1.044</b>	<b>1.032</b>
	0,367 45	L. 480	SL1PB6426	<b>1.017</b>	<b>1.038</b>	<b>1.092</b>	<b>1.116</b>	<b>1.112</b>
0,480 53	L. 640	SL1PB6436	<b>1.108</b>	<b>1.120</b>	<b>1.178</b>	<b>1.205</b>	<b>1.219</b>	



N.B: L'interno del mobile e del vano a giorno è in materico abbinato per il rovere termotrattato e nodi, in laccato opaco in tinta per i laccati, le superfici UP e per le essenze rovere gesso, visone, cenere e castoro

- Ante vetro UP: sono utilizzabili esclusivamente su pensili senza l'impiego di top - Apertura tramite presa laterale sul telaio dell'anta, sono disponibili solo in vetro trasparente grigio - Specificare nell'ordine se a terra o sospesi   In the order, specify whether positioned free-standing or supported - UP glass doors: they can only be used on wall units with no tops - Side grip opening on the glass door frame. Only available in a grey transparent glass.	<b>codice</b>	<b>lacc. opaco</b>	<b>essenza cat. 1</b>	<b>essenza cat. 2</b>	<b>rovere lacc.</b>	<b>lacc. lucido</b>
	<b>code</b>	<b>matt lacq.</b>	<b>wood cat. 1</b>	<b>wood cat. 2</b>	<b>matt lacq. oak</b>	<b>glossy lacq.</b>
						<b>superfici UP</b> UP surface

Pensile con 1 anta vetro UP  
 specificare nell'ordine se apertura dx o sx; sempre ripiani vetro dietro l'anta  
 Wall unit with 1 UP glass door  
 in the order, specify if the opening is rh or lh; always glass shelves behind the door

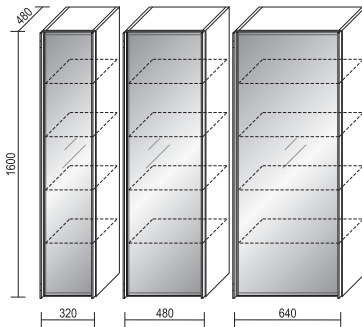

VOLm³	Kg	vetro trasparente grigio grey transparent glass						
0,318	44	L. 320	SL1PBU417	<b>795</b>	<b>842</b>	<b>898</b>	<b>925</b>	<b>900</b>
0,459	57	L. 480	SL1PBU427	<b>874</b>	<b>912</b>	<b>973</b>	<b>1.002</b>	<b>985</b>
0,580	63	L. 640	SL1PBU437	<b>972</b>	<b>1.009</b>	<b>1.076</b>	<b>1.108</b>	<b>1.097</b>

Pensile con 1 anta vetro UP  
 specificare nell'ordine se apertura dx o sx; sempre ripiani vetro dietro l'anta  
 Wall unit with 1 UP glass door  
 in the order, specify if the opening is rh or lh; always glass shelves behind the door

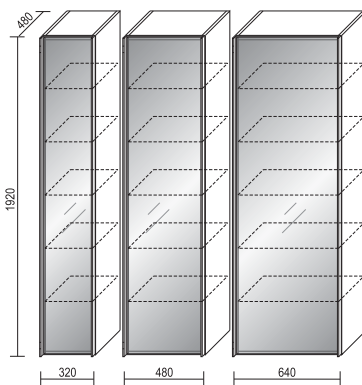

VOLm³	Kg	vetro trasparente grigio grey transparent glass						
0,383	53	L. 320	SL1PBU418	<b>901</b>	<b>949</b>	<b>1.013</b>	<b>1.045</b>	<b>1.018</b>
0,554	68	L. 480	SL1PBU428	<b>989</b>	<b>1.027</b>	<b>1.096</b>	<b>1.129</b>	<b>1.113</b>
0,693	83	L. 640	SL1PBU438	<b>1.099</b>	<b>1.141</b>	<b>1.216</b>	<b>1.253</b>	<b>1.240</b>

Pensile con 4 ante vetro UP  
 il ripiano di divisione tra le ante è fisso in legno, gli altri sono sempre vetro  
 Wall unit with 4 UP glass doors  
 the dividing shelf between the doors is a wooden fixed one; the others are always glass shelves

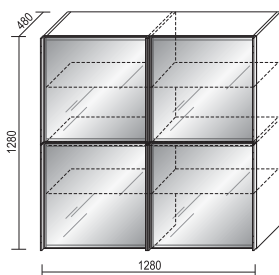

VOLm³	Kg	vetro trasparente grigio grey transparent glass						
0,927	104	L. 1280	SL1PB6466	<b>2.084</b>	<b>2.057</b>	<b>2.147</b>	<b>2.182</b>	<b>2.225</b>

N.B: The interior of the cabinet and open compartment has matching textured f. for heat-treated oak and oak knots finishes and matching matte lacquer for lacquers, UP surfaces, in addition to oak gesso, oak visone, oak cenere and oak castoro woods.

Il prezzo totale è dato dalla somma di SCOCCHA VUOTA (1) + FRONTALI (2) + RIPIANO (3)  
 The total price is given by the sum of the EMPTY BODY (1) + FRONTS (2) + SHELF (3)

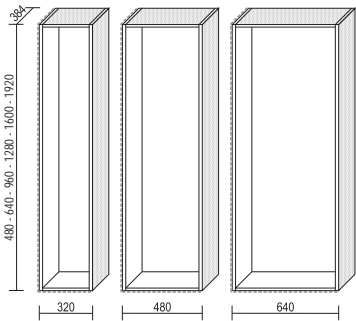
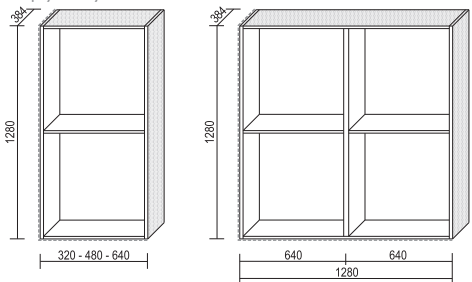
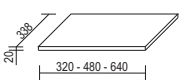
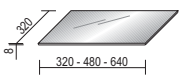
		codice code	lacc. opaco matt lacq.	essenza cat. 1 wood cat. 1	essenza cat. 2 wood cat. 2	rovere lacc. matt lacq. oak	lacc. lucido glossy lacq.	superfici UP UP surface		
SCOCHE VUOTE   EMPTY BODIES	(1) Scocca vuota elemento 1 vano Empty body for element with 1 compartment  	<b>L. 320</b>								
		H. 480	SL1P01312	151	177	204	214	191		
		H. 640	SL1P01313	172	204	234	247	219		
		H. 960	SL1P01315	224	259	297	315	289		
		H. 1280	SL1P01316	276	312	359	381	358		
		H. 1600	SL1P01317	320	362	414	440	415		
		H. 1920	SL1P01318	364	409	468	498	472		
		<b>L. 480</b>								
		H. 480	SL1P01322	170	198	226	239	219		
		H. 640	SL1P01323	195	227	259	274	251		
		H. 960	SL1P01325	248	281	322	342	320		
		H. 1280	SL1P01326	301	335	384	408	388		
		H. 1600	SL1P01327	346	381	436	464	447		
		H. 1920	SL1P01328	390	427	489	521	505		
		<b>L. 640</b>								
		H. 480	SL1P01332	192	216	248	263	249		
		H. 640	SL1P01333	220	249	285	302	286		
		H. 960	SL1P01335	278	308	353	374	362		
		H. 1280	SL1P01336	336	368	421	447	438		
		H. 1600	SL1P01337	383	413	474	504	496		
		H. 1920	SL1P01338	427	458	525	560	555		
		SCOCHE VUOTE   EMPTY BODIES	Scocca vuota elemento 2 o 4 ante con ripiano fisso Empty body for element with 2 or 4 doors and fixed shelf  	L. 320	SL1P02316	307	336	383	404	389
				L. 480	SL1P02326	340	361	410	434	427
				L. 640	SL1P02336	382	397	450	476	483
				L. 1280	SL1P02366	650	624	707	741	778
RIPIANI   SHELVES	(3) Ripiano legno Wooden shelf  	VOLm <sup>3</sup> Kg	lacc. opaco matt lacq.		materico textured finish					
		0,008 1,5	L. 320	SL1R01311	33	26				
		0,010 2	L. 480	SL1R01321	39	29				
		0,014 3	L. 640	SL1R01331	46	33				
	Ripiano vetro Glass shelf  	VOLm <sup>3</sup> Kg	vetro / glass							
		0,005 2,5	L. 320	SL1R02310	15					
		0,008 3,5	L. 480	SL1R02320	17					
		0,011 5	L. 640	SL1R02330	19					

N.B: L'interno del mobile e del vano a giorno è in materico abbinato per il rovere temottrattato e nodi, in laccato opaco in tinta per i laccati, le superfici UP e per le essenze rovere gesso, visone, cenere e castoro

Il prezzo totale è dato dalla somma di SCOCCHA VUOTA (1) + FRONTALI (2) + RIPIANO (3)  
 The total price is given by the sum of the EMPTY BODY (1) + FRONTS (2) + SHELF (3)

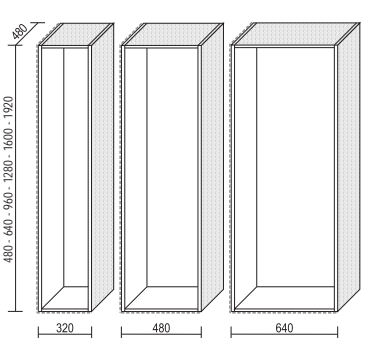
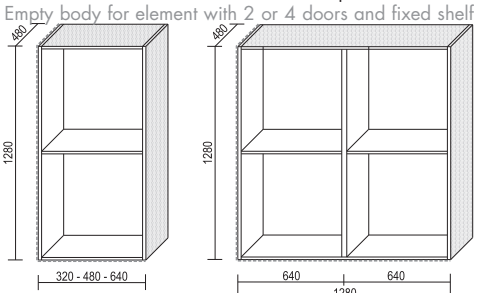
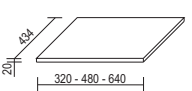
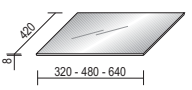
		codice code	lacc. opaco matt lacq.	essenza cat. 1 wood cat. 1	essenza cat. 2 wood cat. 2	rovere lacc. matt lacq. oak	lacc. lucido glossy lacq.		
							superfici UP UP surface		
SCOCHE VUOTE   EMPTY BODIES	(1) Scocca vuota elemento 1 vano Empty body for element with 1 compartment  	<b>L. 320</b>							
		H. 480	SL1P01412	165	195	225	237	210	
		H. 640	SL1P01413	187	222	256	270	239	
		H. 960	SL1P01415	245	283	324	343	316	
		H. 1280	SL1P01416	302	341	391	414	390	
		H. 1600	SL1P01417	349	396	452	479	454	
		H. 1920	SL1P01418	399	447	511	543	516	
		<b>L. 480</b>							
		H. 480	SL1P01422	187	218	249	263	241	
		H. 640	SL1P01423	213	248	283	300	275	
		H. 960	SL1P01425	270	307	351	372	349	
		H. 1280	SL1P01426	329	366	420	444	425	
		H. 1600	SL1P01427	377	415	476	505	488	
		H. 1920	SL1P01428	427	465	534	567	551	
		<b>L. 640</b>							
		H. 480	SL1P01432	211	239	273	289	274	
		H. 640	SL1P01433	240	272	310	329	312	
		H. 960	SL1P01435	304	336	385	408	396	
		H. 1280	SL1P01436	368	401	459	486	478	
		H. 1600	SL1P01437	420	457	524	556	545	
H. 1920	SL1P01438	470	512	587	624	611			
SCOCHE VUOTE   EMPTY BODIES	Scocca vuota elemento 2 o 4 ante con ripiano fisso Empty body for element with 2 or 4 doors and fixed shelf  	L. 320	SL1P02416	340	367	417	440	428	
		L. 480	SL1P02426	373	394	448	472	468	
		L. 640	SL1P02436	420	432	490	517	531	
		L. 1280	SL1P02466	708	681	771	806	849	
RIPIANI   SHELVES	(3) Ripiano legno Wooden shelf  			lacc. opaco matt lacq.	materico textured finish				
		L. 320	SL1R01411	38	29				
		L. 480	SL1R01421	45	32				
		L. 640	SL1R01431	53	35				
	Ripiano vetro Glass shelf  			vetro / glass					
		L. 320	SL1R02410	16					
		L. 480	SL1R02420	18					
		L. 640	SL1R02430	21					



N.B: L'interno del mobile e del vano a giorno è in materico abbinato per il rovere termotrattato e nodi, in laccato opaco in tinta per i laccati, le superfici UP e per le essenze rovere gesso, visone, cenere e castoro

Il prezzo totale è dato dalla somma di SCOCCA VUOTA (1) + FRONTALI (2) + RIPIANO (3)  
The total price is given by the sum of the EMPTY BODY (1) + FRONTS (2) + SHELF (3)

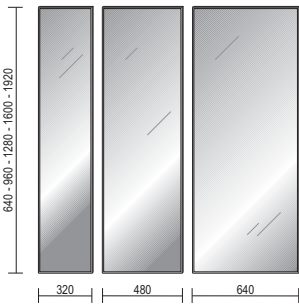
		codice code	vetro glass cat. 1	vetro glass cat. 2	
<p>(2) Anta vetro SLIM   SLIM Glass door specificare nell'ordine se apertura dx o sx in the order, specify if the opening is rh or lh</p> 	VOLm³ Kg	<b>L. 320</b>			
	0,015 4	H. 640 SL1A21224	<b>164</b>	<b>189</b>	
	0,022 5,5	H. 960 SL1A21225	<b>216</b>	<b>250</b>	
	0,029 7	H. 1280 SL1A21226	<b>268</b>	<b>309</b>	
	0,036 8,5	H. 1600 SL1A21227	<b>301</b>	<b>357</b>	
	0,043 10	H. 1920 SL1A21228	<b>333</b>	<b>404</b>	
		<b>L. 480</b>			
	0,022 5,5	H. 640 SL1A21244	<b>192</b>	<b>227</b>	
	0,032 8	H. 960 SL1A21245	<b>252</b>	<b>307</b>	
	0,042 10	H. 1280 SL1A21246	<b>315</b>	<b>389</b>	
	0,052 12,5	H. 1600 SL1A21247	<b>355</b>	<b>448</b>	
	0,063 14,5	H. 1920 SL1A21248	<b>398</b>	<b>506</b>	
		<b>L. 640</b>			
	0,028 7	H. 640 SL1A21264	<b>219</b>	<b>265</b>	
	0,042 10	H. 960 SL1A21265	<b>290</b>	<b>368</b>	
	0,055 13,5	H. 1280 SL1A21266	<b>358</b>	<b>468</b>	
	0,069 16,5	H. 1600 SL1A21267	<b>411</b>	<b>539</b>	
	0,082 19,5	H. 1920 SL1A21268	<b>463</b>	<b>609</b>	
	<p>Anta vetro UP sono utilizzabili esclusivamente su pensili senza l'impiego di top, sono disponibili solo in vetro trasparente grigio. Specificare nell'ordine se apertura dx o sx</p> <p>UP Glass door they can only be used on wall units with no tops. Only available in a grey transparent glass. In the order, specify if the opening is rh or lh</p>				
		VOLm³ Kg	<b>L. 320</b>	vetro trasp. grigio grey transp. glass	
		0,015 4,5	H. 640 SL1A21324	<b>286</b>	
		0,022 6	H. 960 SL1A21325	<b>321</b>	
		0,029 7,5	H. 1280 SL1A21326	<b>355</b>	
		0,036 9	H. 1600 SL1A21327	<b>382</b>	
		0,043 10,5	H. 1920 SL1A21328	<b>422</b>	
		<b>L. 480</b>			
	0,022 6	H. 640 SL1A21344	<b>304</b>		
	0,032 8,5	H. 960 SL1A21345	<b>349</b>		
	0,042 10,5	H. 1280 SL1A21346	<b>389</b>		
	0,052 13	H. 1600 SL1A21347	<b>425</b>		
	0,063 15	H. 1920 SL1A21348	<b>472</b>		
		<b>L. 640</b>			
	0,028 7,5	H. 640 SL1A21364	<b>323</b>		
	0,042 10,5	H. 960 SL1A21365	<b>374</b>		
	0,055 14	H. 1280 SL1A21366	<b>424</b>		
	0,069 17	H. 1600 SL1A21367	<b>468</b>		
	0,082 20	H. 1920 SL1A21368	<b>524</b>		

FRONTALI VETRO | GLASS FRONTS

**TOP LEGNO PER RIBALTE E PENSILI ANTA BATTENTE | WOODEN TOP FOR HINGED-DOOR AND FLAP-DOOR WALL UNITS P. | D. 388-484**

N.B: The interior of the cabinet and open compartment has matching textured f. for heat-treated oak and oak knots finishes and matching matte lacquer for lacquers, UP surfaces, in addition to oak gesso, oak visone, oak cenere and oak castoro woods.

- Consigliamo l'utilizzo del top Sp.15 per elementi posizionati ad una altezza da terra inferiore a 1600, in tutti gli altri casi il top non è necessario.  
 - We recommend using the top th.15 mm for elements positioned at a height of less than 1600 mm from the ground. In all the other cases the top is unnecessary.

codice code	lacc. opaco matt lacq.	essenza cat. 1 wood cat. 1	essenza cat. 2 wood cat. 2	rovere lacc. matt lacq. oak	lacc. lucido glossy lacq.
					superfici UP UP surface

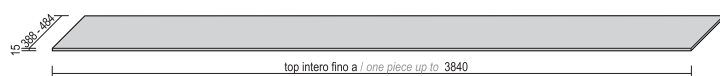

**P. | D. 388**

VOLm³	Kg
0,008	1,7
0,012	2,3
0,016	2,9
0,024	4,1
0,027	4,8
0,031	5,3
0,035	6
0,039	6,5
0,046	7,8
0,054	9
0,061	10,2
0,065	11,4
0,069	12
0,076	13,2
0,084	14,5
0,091	15,7

L. 320	SL1T013A0	31	50	58	61	45
L. 480	SL1T013B0	36	61	70	74	53
L. 640	SL1T013C0	39	69	78	84	62
L. 960	SL1T013D0	52	89	102	110	86
L. 1120	SL1T013E0	57	100	115	124	98
L. 1280	SL1T013F0	62	111	127	137	110
L. 1440	SL1T013G0	72	124	141	152	121
L. 1600	SL1T013H0	78	134	155	167	137
L. 1920	SL1T013L0	87	160	184	199	157
L. 2240	SL1T013M0	102	184	210	227	182
L. 2560	SL1T013N0	113	207	238	258	207
L. 2720	SL1T013O0	125	224	260	280	225
L. 2880	SL1T013P0	130	235	270	292	236
L. 3200	SL1T013R0	146	260	299	322	263
L. 3520	SL1T013S0	160	283	326	351	288
L. 3840	SL1T013T0	173	308	354	383	314

**P. | D. 484**

VOLm³	Kg
0,011	2
0,015	2,8
0,020	3,5
0,029	5
0,033	5,8
0,038	6,5
0,043	7,5
0,047	8
0,057	9,5
0,066	11
0,075	13,5
0,080	14
0,084	14,5
0,093	16,3
0,103	17,8
0,112	19,3

L. 320	SL1T014A0	43	53	63	66	61
L. 480	SL1T014B0	46	57	65	71	63
L. 640	SL1T014C0	52	65	75	81	78
L. 960	SL1T014D0	69	96	108	118	106
L. 1120	SL1T014E0	77	106	123	133	121
L. 1280	SL1T014F0	85	120	138	150	135
L. 1440	SL1T014G0	90	130	150	164	150
L. 1600	SL1T014H0	105	139	160	175	173
L. 1920	SL1T014L0	119	159	183	201	198
L. 2240	SL1T014M0	138	197	227	248	229
L. 2560	SL1T014N0	155	206	238	262	259
L. 2720	SL1T014O0	166	224	259	283	278
L. 2880	SL1T014P0	173	226	261	288	291
L. 3200	SL1T014R0	197	278	321	350	327
L. 3520	SL1T014S0	218	297	343	375	359
L. 3840	SL1T014T0	237	301	346	382	389

- Esempio di utilizzo di scaffalature pensili accostate tra loro per comporre una libreria pensile.  
 - È possibile l'integrazione di scaffalature pensili con le basi come da esempio sottostante. L'elemento sopra la base però deve essere tagliato a misura per permettere l'inserimento del top.

- Example of the use of wall shelving systems placed one next to the other, in order to compose a hanging bookcase.  
 - It's possible to integrate wall shelving system with bases as per the example below. The element positioned on the base shall be cut down to size, in order to allow the insertion of the top.

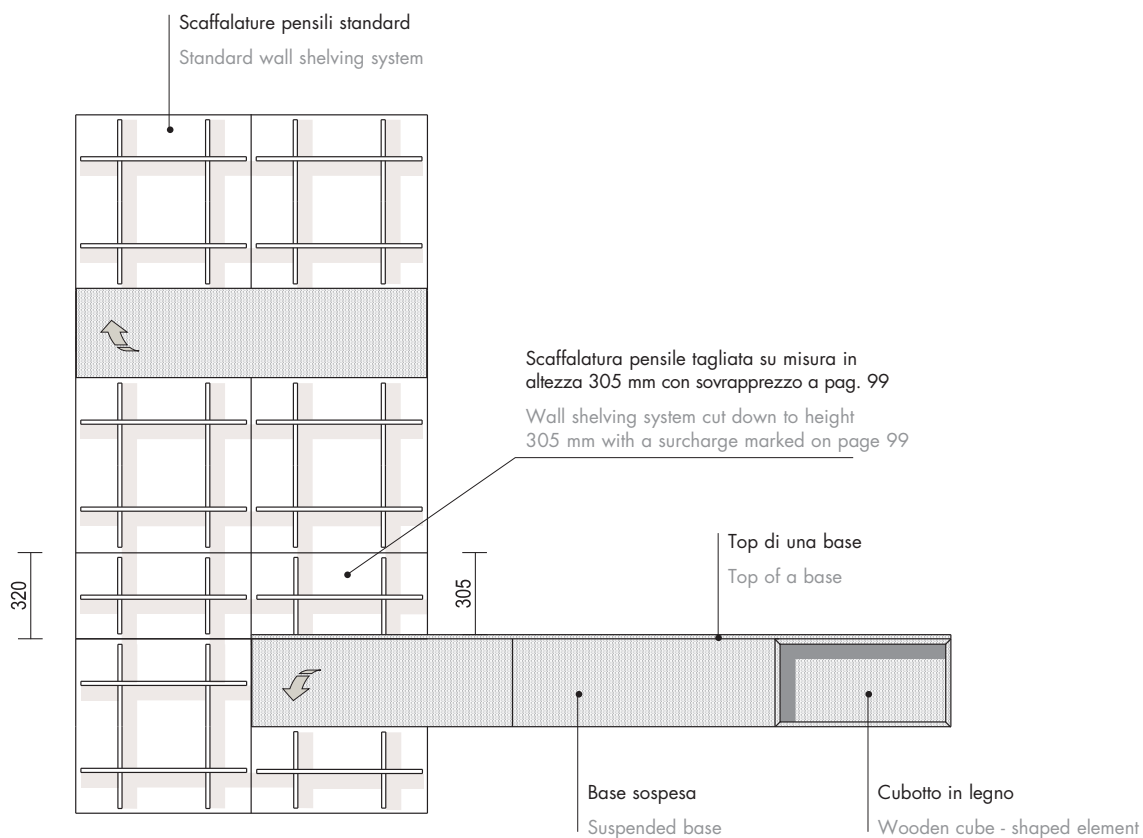

- Scaffalatura pensile composta da moduli singoli accostabili in orizzontale o verticale.  
 Attenzione: nell'accostamento tra moduli verticali ed orizzontali ci sarà una differenza nel senso vena delle essenze.  
 - Wall shelving system made up of single modules which can be placed in a horizontal or vertical position. Please note: When vertical and horizontal modules are placed next to each other, the direction of the wood grain will be different.

codice code	lacc. opaco matt lacq.	essenza cat. 1 wood cat. 1	essenza cat. 2 wood cat. 2	rovere lacc. matt lacq. oak	lacc. lucido glossy lacq.
					superfici UP UP surface

Scaffalatura pensile L.320  
 Wall shelving system L. 320

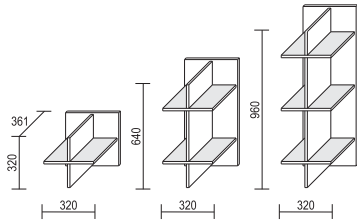

VOL.m³	Kg	L. 320
0,048	6	H. 320
0,092	10	H. 640
0,135	14	H. 960

		147	189	219	235	182
	SL1S20311					
	SL1S20313	223	287	330	354	293
	SL1S20315	321	414	477	506	426
taglio per top   cut for top		61	61	61	61	61

Scaffalatura pensile L.640  
 Wall shelving system L. 640

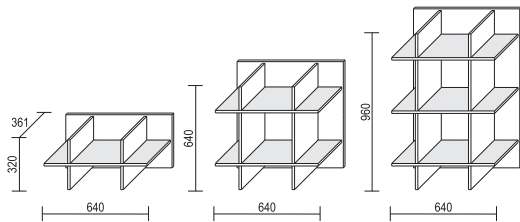

VOL.m³	Kg	L.640
0,092	10	H. 320
0,176	18	H. 640
0,259	25	H. 960

		223	287	330	354	293
	SL1S20331					
	SL1S20333	405	522	601	643	545
	SL1S20335	575	741	853	913	785
taglio per top   cut for top		84	84	84	84	84

Scaffalatura pensile L.960  
 Wall shelving system L. 960

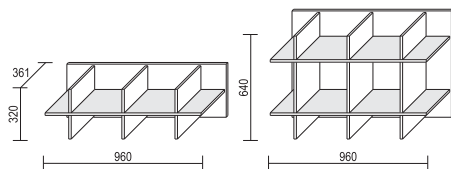

VOL.m³	Kg	L.960
0,135	14	H. 320
0,259	25	H. 640

		321	414	477	506	426
	SL1S20351					
	SL1S20353	575	741	853	913	785
taglio per top   cut for top		102	102	102	102	102

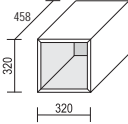
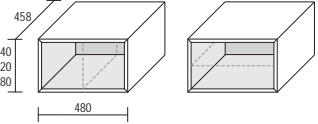
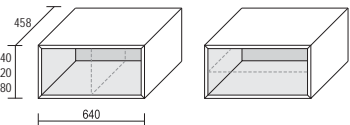
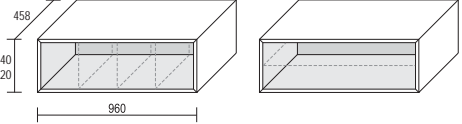
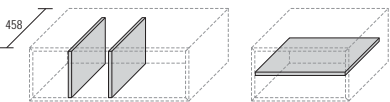

- Cubotti da posizionare accostati a basi a terra P.480, oppure come moduli singoli. - I cubotti sono realizzati in folding con taglio a 45°, possono essere vuoti o attrezzati con ripiani/divisioni sp. 20 mm nelle posizioni indicate, sono dotati di piedini di supporto H.16. - Wooden cubes to be placed next to free-standing bases D. 480, or as single modules. - The cubes are produced via a folding process with 45° cuts. They can be empty or fitted with 20 mm-thick shelves/partitions in the indicated positions. They are fitted with 16 mm-high support feet.				codice code	lacc. opaco matt lacq.	essenza cat. 1 wood cat. 1	essenza cat. 2 wood cat. 2	rovere lacc. matt lacq. oak	lacc. lucido glossy lacq.		
									superfici UP UP surface		
Cubotti legno verticali L.320 Vertical wooden cube - shaped elements L. 320											
				VOLm³ Kg 0,059 10	P.   D. 458 H. 320	SL1CT0412	248	340	400	414	295
Cubotti legno orizzontali L. 480 Horizontal wooden cube - shaped elements L. 480											
				VOLm³ Kg 0,073 10,3 0,093 11,5 0,135 14	P.   D. 458 H. 240 H. 320 H. 480	SL1CT0421 SL1CT0422 SL1CT0423	260 270 297	375 393 431	450 471 517	472 493 542	317 331 363
Cubotti legno orizzontali L. 640 Horizontal wooden cube - shaped elements L. 640											
				VOLm³ Kg 0,095 12,5 0,115 14 0,176 16,2	P.   D. 458 H. 240 H. 320 H. 480	SL1CT0431 SL1CT0432 SL1CT0433	287 297 326	416 431 469	499 517 563	522 542 589	351 363 397
Cubotti legno orizzontali L. 960 Horizontal wooden cube - shaped elements L. 960											
				VOLm³ Kg 0,139 16,8 0,169 18	P.   D. 458 H. 240 H. 320	SL1CT0451 SL1CT0452	329 346	476 524	571 623	597 606	400 431
Ripiani o divisioni legno P. 458, da posizionare all'interno dei cubotti nelle posizioni indicate Wooden shelves or partitions D. 458, to be placed inside the cubes at the indicated positions											
Eventuali posizionamenti su misura con sovrapprezzo: Any customised positions will be an additional: € 38,00											
				Kg 1,8 2,5 3,8 5,5	P.   D. 458 Ripiano   Shelf L. 320 L. 480 L. 640 L. 960	SL1R03411 SL1R03421 SL1R03431 SL1R03451	45 53 63 84	63 75 91 121	73 87 106 140	79 94 117 156	63 79 99 138
				Kg 1,2 1,8 2,5	Divisione   Partition H. 240 H. 320 H. 480	SL1R04411 SL1R04412 SL1R04413	42 45 53	59 63 75	69 73 87	73 79 94	59 63 79

- Cubotti da posizionare accostati a basi sospese, el. pensili, P. 384-480, o come moduli singoli.  
 - I cubotti sono realizzati in folding con taglio a 45° e possono essere vuoti o attrezzati con ripiani/divisioni sp. 20 mm nelle posizioni indicate.  
 - Wooden cubes to be placed next to suspending bases or wall units D. 384-480, or as single modules.  
 - The cubes are produced via a folding process with 45° cuts. They can be empty or fitted with 20 mm-thick shelves/partitions in the indicated positions.

codice code	lacc. opaco matt lacq.	essenza cat. 1 wood cat. 1	essenza cat. 2 wood cat. 2	rovere lacc. matt lacq. oak	lacc. lucido glossy lacq.	superfici UP UP surface
-------------	------------------------	----------------------------	----------------------------	-----------------------------	---------------------------	-------------------------

**Cubotti legno verticali L.320**  
 Vertical wooden cube - shaped elements L. 320

VOLm³	Kg	P.   D. 362						
0,048	8	H. 320	SL1CS0312	241	306	362	380	278
0,075	9,5	H. 480	SL1CS0313	264	345	410	432	312
0,091	12	H. 640	SL1CS0314	286	384	457	484	345
0,135	16	H. 960	SL1CS0315	333	464	550	586	414
VOLm³	Kg	P.   D. 458						
0,059	10	H. 320	SL1CS0412	256	342	400	422	303
0,093	11,5	H. 480	SL1CS0413	277	401	481	504	339
0,115	14	H. 640	SL1CS0414	306	440	528	553	372
0,169	18	H. 960	SL1CS0415	362	530	627	671	448

**Cubotti legno orizzontali L. 480**  
 Horizontal wooden cube - shaped elements L. 480

VOLm³	Kg	P.   D. 362						
0,059	8,5	H. 240	SL1CS0321	252	314	373	394	290
0,075	9,5	H. 320	SL1CS0322	264	345	410	432	312
0,109	11,5	H. 480	SL1CS0323	286	384	457	484	345
VOLm³	Kg	P.   D. 458						
0,073	10,3	H. 240	SL1CS0421	264	366	438	458	316
0,093	11,5	H. 320	SL1CS0422	277	401	481	504	339
0,135	14	H. 480	SL1CS0423	306	440	528	553	372

**Cubotti legno orizzontali L. 640**  
 Horizontal wooden cube - shaped elements L. 640

VOLm³	Kg	P.   D. 362						
0,077	10	H. 240	SL1CS0331	273	349	416	441	321
0,091	12	H. 320	SL1CS0332	286	384	457	484	345
0,142	13,5	H. 480	SL1CS0333	306	417	496	526	370
VOLm³	Kg	P.   D. 458						
0,068	11	H. 160	SL1CS0430	282	373	448	469	332
0,095	12,5	H. 240	SL1CS0431	292	400	480	504	346
0,115	14	H. 320	SL1CS0432	306	440	528	553	372
0,176	16,2	H. 480	SL1CS0433	337	484	580	610	410

**Cubotti legno orizzontali L. 960**  
 Horizontal wooden cube - shaped elements L. 960

VOLm³	Kg	P.   D. 362						
0,113	13,7	H. 240	SL1CS0351	318	422	501	533	386
0,135	16	H. 320	SL1CS0352	333	464	550	586	414
VOLm³	Kg	P.   D. 458						
0,100	15,5	H. 160	SL1CS0450	335	449	532	569	400
0,139	16,8	H. 240	SL1CS0451	346	482	571	611	417
0,169	18	H. 320	SL1CS0452	362	530	627	671	448

**Ripiani o divisioni legno P. 362,**  
 da posizionare all'interno dei cubotti nelle posizioni indicate  
 Wooden shelves or partitions D. 362,  
 to be placed inside the cubes at the indicated positions

Eventuali posizionamenti su misura con sovrapprezzo:  
 Any customised positions will be an additional:  
**€ 38,00**

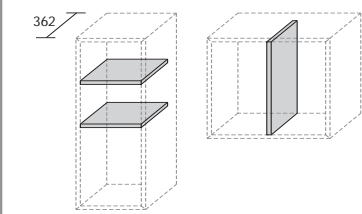

Kg	P.   D. 362						
	<b>Ripiano   Shelf</b>						
1,4	L. 320	SL1R03311	40	57	65	72	57
2	L. 480	SL1R03321	48	67	78	85	72
3	L. 640	SL1R03331	57	81	96	105	89
4,5	L. 960	SL1R03351	75	108	126	140	124
Kg	<b>Divisione   Partition</b>						
1	H. 240	SL1R04311	37	53	62	65	53
1,4	H. 320	SL1R04312	40	57	65	72	57
2	H. 480	SL1R04313	48	67	78	85	72

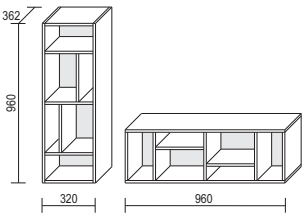
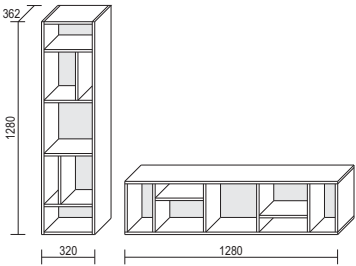
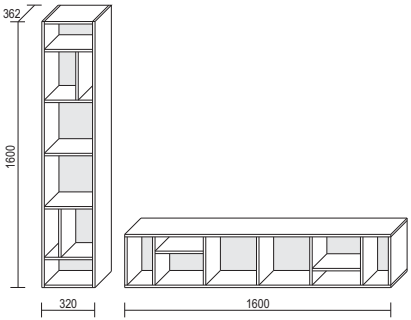
- Elementi sp. 15 mm, con schiena della stessa finitura della struttura. - Elements th. 15 mm, with a back in the same finish as the structure.		codice	lacc. opaco	essenza cat. 1	essenza cat. 2	rovere lacc.	lacc. lucido	
		code	matt lacq.	wood cat. 1	wood cat. 2	matt lacq. oak	glossy lacq.	
							superfici UP UP surface	
<p>Elemento pensile a giorno Open wall unit</p> 								
<p>VOLm<sup>3</sup> Kg 0,145 16,5</p>		Altezza   Height 960	SL1PG0315	<b>359</b>	<b>542</b>	<b>644</b>	<b>702</b>	<b>592</b>
		Larghezza   Width 960	SL1PG0351	<b>359</b>	<b>542</b>	<b>644</b>	<b>702</b>	<b>592</b>
<p>Elemento pensile a giorno Open wall unit</p> 								
<p>VOLm<sup>3</sup> Kg 0,191 20,5</p>		Altezza   Height 1280	SL1PG0316	<b>442</b>	<b>650</b>	<b>774</b>	<b>844</b>	<b>732</b>
		Larghezza   Width 1280	SL1PG0361	<b>442</b>	<b>650</b>	<b>774</b>	<b>844</b>	<b>732</b>
<p>Elemento pensile a giorno Open wall unit</p> 								
<p>VOLm<sup>3</sup> Kg 0,237 24,5</p>		Altezza   Height 1600	SL1PG0317	<b>523</b>	<b>758</b>	<b>901</b>	<b>983</b>	<b>872</b>
		Larghezza   Width 1600	SL1PG0371	<b>523</b>	<b>758</b>	<b>901</b>	<b>983</b>	<b>872</b>

- Elementi sp. 15 mm, con schiena della stessa finitura della struttura.  
 - Elements th. 15 mm, with a back in the same finish as the structure.

codice code	lacc. opaco matt lacq.	essenza cat. 1 wood cat. 1	essenza cat. 2 wood cat. 2	rovere lacc. matt lacq. oak	lacc. lucido glossy lacq.
					superfici UP UP surface

Elemento pensile a giorno  
 Open wall unit

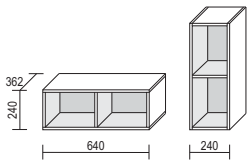

VOLm³ Kg  
 0,077 9,0

Altezza   Height	640	SL1PG0303	<b>225</b>	<b>340</b>	<b>403</b>	<b>432</b>	<b>371</b>
Larghezza   Width	640	SL1PG0330	<b>225</b>	<b>340</b>	<b>403</b>	<b>432</b>	<b>371</b>

Elemento pensile a giorno  
 Open wall unit

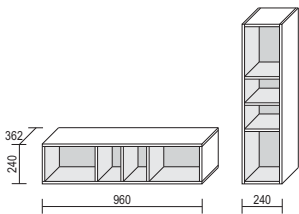

VOLm³ Kg  
 0,113 11,8

Altezza   Height	960	SL1PG0305	<b>320</b>	<b>484</b>	<b>575</b>	<b>621</b>	<b>530</b>
Larghezza   Width	960	SL1PG0350	<b>320</b>	<b>484</b>	<b>575</b>	<b>621</b>	<b>530</b>

Elemento pensile a giorno  
 Open wall unit

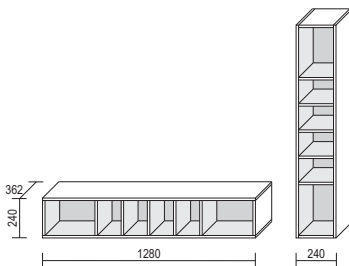

VOLm³ Kg  
 0,149 17

Altezza   Height	1280	SL1PG0306	<b>396</b>	<b>580</b>	<b>691</b>	<b>750</b>	<b>654</b>
Larghezza   Width	1280	SL1PG0360	<b>396</b>	<b>580</b>	<b>691</b>	<b>750</b>	<b>654</b>

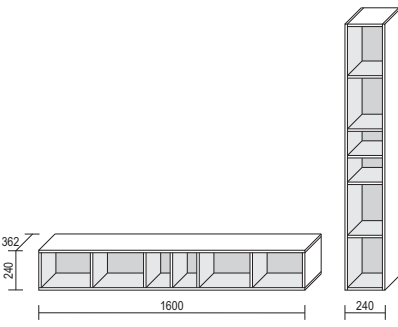
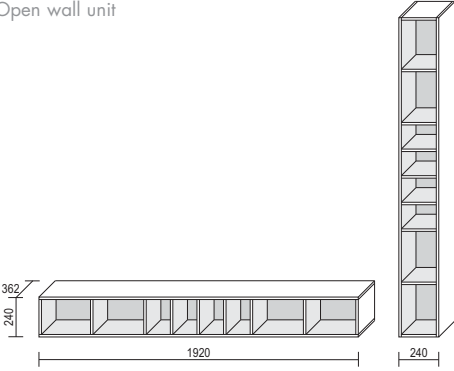
- Elementi sp. 15 mm, con schiena della stessa finitura della struttura. - Elements th. 15 mm, with a back in the same finish as the structure.	<b>codice</b> code	<b>lacc. opaco</b> matt lacq.	<b>essenza cat. 1</b> wood cat. 1	<b>essenza cat. 2</b> wood cat. 2	<b>rovere lacc.</b> matt lacq. oak	<b>lacc. lucido</b> glossy lacq.  superfici UP UP surface																
<p>Elemento pensile a giorno Open wall unit</p>  <p>VOLm<sup>3</sup> Kg 0,185 20</p> <table border="1" data-bbox="646 907 1517 974"> <tr> <td>Altezza   Height</td> <td>1600</td> <td>SL1PG0307</td> <td><b>468</b></td> <td><b>678</b></td> <td><b>805</b></td> <td><b>879</b></td> <td><b>779</b></td> </tr> <tr> <td>Larghezza   Width</td> <td>1600</td> <td>SL1PG0370</td> <td><b>468</b></td> <td><b>678</b></td> <td><b>805</b></td> <td><b>879</b></td> <td><b>779</b></td> </tr> </table>	Altezza   Height	1600	SL1PG0307	<b>468</b>	<b>678</b>	<b>805</b>	<b>879</b>	<b>779</b>	Larghezza   Width	1600	SL1PG0370	<b>468</b>	<b>678</b>	<b>805</b>	<b>879</b>	<b>779</b>						
Altezza   Height	1600	SL1PG0307	<b>468</b>	<b>678</b>	<b>805</b>	<b>879</b>	<b>779</b>															
Larghezza   Width	1600	SL1PG0370	<b>468</b>	<b>678</b>	<b>805</b>	<b>879</b>	<b>779</b>															
<p>Elemento pensile a giorno Open wall unit</p>  <p>VOLm<sup>3</sup> Kg 0,221 23</p> <table border="1" data-bbox="646 1467 1517 1534"> <tr> <td>Altezza   Height</td> <td>1920</td> <td>SL1PG0308</td> <td><b>551</b></td> <td><b>799</b></td> <td><b>950</b></td> <td><b>1.036</b></td> <td><b>918</b></td> </tr> <tr> <td>Larghezza   Width</td> <td>1920</td> <td>SL1PG0380</td> <td><b>551</b></td> <td><b>799</b></td> <td><b>950</b></td> <td><b>1.036</b></td> <td><b>918</b></td> </tr> </table>	Altezza   Height	1920	SL1PG0308	<b>551</b>	<b>799</b>	<b>950</b>	<b>1.036</b>	<b>918</b>	Larghezza   Width	1920	SL1PG0380	<b>551</b>	<b>799</b>	<b>950</b>	<b>1.036</b>	<b>918</b>						
Altezza   Height	1920	SL1PG0308	<b>551</b>	<b>799</b>	<b>950</b>	<b>1.036</b>	<b>918</b>															
Larghezza   Width	1920	SL1PG0380	<b>551</b>	<b>799</b>	<b>950</b>	<b>1.036</b>	<b>918</b>															

- Elementi sp. 15 mm con schiena della stessa finitura della struttura. La griglia metallica può essere in finitura brunita, ottone, titanio o bianca da specificare in conferma d'ordine.  
 - Elements th. 15 mm, with a back in the same finish as the structure. The metal grill can have a burnished, brass, titanium or white finish and this must be specified when confirming the order.

codice code	lacc. opaco matt lacq.	essenza cat. 1 wood cat. 1	essenza cat. 2 wood cat. 2	rovere lacc. matt lacq. oak	lacc. lucido glossy lacq.
-------------	------------------------	----------------------------	----------------------------	-----------------------------	---------------------------

Elemento pensile a giorno orizzontale L. 960  
 Horizontal open wall unit L. 960

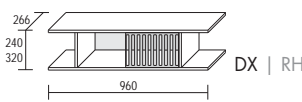

VOLm <sup>3</sup>	Kg	H. 240							
0,086	9	DX   RH	SL1PG1250D	334	489	561	600	493	
		SX   LH	SL1PG1250S	334	489	561	600	493	
VOLm <sup>3</sup>	Kg	H. 320							
0,110	10	DX   RH	SL1PG1251D	378	551	632	675	556	
		SX   LH	SL1PG1251S	378	551	632	675	556	

Elemento pensile a giorno orizzontale L. 1280  
 Horizontal open wall unit L. 1280

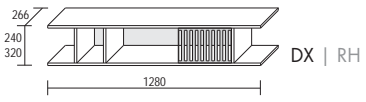

VOLm <sup>3</sup>	Kg	H. 240							
0,113	12	DX   RH	SL1PG1260D	383	552	638	687	575	
		SX   LH	SL1PG1260S	383	552	638	687	575	
VOLm <sup>3</sup>	Kg	H. 320							
0,145	13	DX   RH	SL1PG1261D	432	623	718	774	647	
		SX   LH	SL1PG1261S	432	623	718	774	647	

Elemento pensile a giorno orizzontale L. 1600  
 Horizontal open wall unit L. 1600

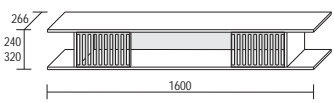

VOLm <sup>3</sup>	Kg	H. 240							
0,141	14,5	H. 240	SL1PG1270	534	723	819	881	763	
0,181	16,5	H. 320	SL1PG1271	606	818	926	995	863	

Elementi pensili a giorno L. 480 H. 480  
 Open wall unit L. 480 H. 480

da utilizzare da soli o in abbinamento  
 To be used on its own or combined with other elements

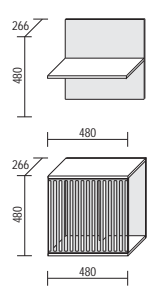

VOLm <sup>3</sup>	Kg	pensile con ripiano wall unit with shelf							
0,083	5	SL1PG1222R	118	142	169	178	157		
VOLm <sup>3</sup>	Kg	pensile con griglia wall unit with grill							
0,083	11	SL1PG1222	358	429	475	492	416		

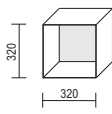
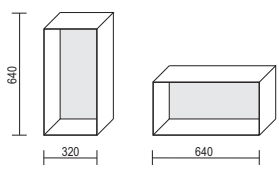
<p>- Elementi in metallo con schiena in pannello di particelle laccato Sp.12 della stessa finitura della struttura. - Metal elements with back in lacquered particleboard Th.12, in the same finish as the structure.</p>	<p><b>codice code</b></p>	<p><b>lacc. opaco matt lacq.</b></p>
<p>Elemento pensile in metallo Metal wall unit</p>  <p style="text-align: right;">VOLm<sup>3</sup> Kg 0,043 7,5</p>	<p>SL1X10311</p>	<p><b>228</b></p>
<p>Elemento pensile in metallo Metal wall unit</p>  <p style="text-align: right;">VOLm<sup>3</sup> Kg 0,085 15</p>	<p>SL1X10331</p>	<p><b>287</b></p>

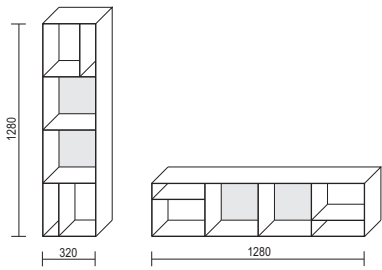
<p>- Elemento in metallo con schiene centrali in pannello di particelle laccato Sp.12 della stessa finitura della struttura. - Metal element with middle backs in lacquered particleboard Th.12, in the same finish as the structure.</p>	<p><b>codice code</b></p>	<p><b>lacc. opaco bianco o nero matt lacq. white or black</b></p>
<p><b>LIBRERIA METAL</b> Libreria in metallo, fornita di piedini regolabili H. 16 se posizionata a terra. Attenzione: per evitare il ribaltamento si consiglia il fissaggio a muro anche quando l'elemento viene appoggiato a terra. Metal bookcase, supplied with adjustable feet H. 16 if free-standing. Attention: the fastening onto the wall is recommended even for free-standing units, to prevent them from tipping over.</p>  <p style="text-align: right;">VOLm<sup>3</sup> Kg 0,140 33</p>	<p>SL1X01339</p>	<p><b>454</b></p>

- Piani posizionabili a terra forniti di piedini regolabili H.10 oppure in appoggio a basi, in questo caso sono forniti di piede di supporto a terra in metallo.  
 - Free-standing benches, provided with 10 mm-high adjustable feet or a support base. In this case, they are fitted with free-standing metal support feet.

codice code	lacc. opaco matt lacq.	essenza cat. 1 wood cat. 1	essenza cat. 2 wood cat. 2	rovere lacc. matt lacq. oak	lacc. lucido glossy lacq.
					superfici UP UP surface

Piani a terra  
 Free-standing benches

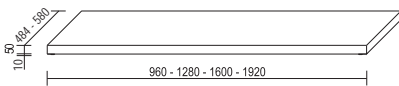

VOLm³	Kg	P.   D. 484						
0,047	15	L. 960	SL1P10452	132	162	200	225	184
0,062	20	L. 1280	SL1P10462	168	200	243	277	231
0,077	24,5	L. 1600	SL1P10472	204	243	291	320	288
0,092	29,5	L. 1920	SL1P10482	242	281	336	372	337
VOLm³	Kg	P.   D. 580						
0,056	17,5	L. 960	SL1P10552	142	173	214	241	196
0,074	23	L. 1280	SL1P10562	180	211	261	297	247
0,092	29	L. 1600	SL1P10572	219	261	323	369	302
0,102	34,5	L. 1920	SL1P10582	259	308	381	435	357

Piani in appoggio,  
 aggiungere sempre il piede di supporto in metallo nelle altezze desiderate,  
 piede disponibile in finitura brown, ottone, titanio o bianco

Supported benches,  
 always add the metal support feet at the desired heights.  
 The feet are available in a brown, brass, titanium or white finish.

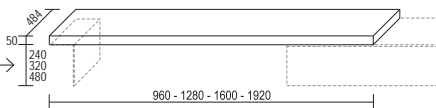

VOLm³	Kg	P.   D. 484						
0,047	15	L. 960	SL1P12452	132	162	200	225	184
0,062	20	L. 1280	SL1P12462	168	200	243	277	231
0,077	24,5	L. 1600	SL1P12472	204	243	291	320	288
0,092	29,5	L. 1920	SL1P12482	242	281	336	372	337

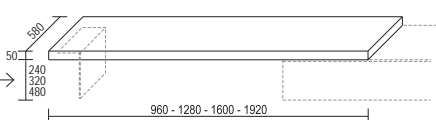

VOLm³	Kg	P.   D. 580						
0,056	17,5	L. 960	SL1P12552	142	173	214	241	196
0,074	23	L. 1280	SL1P12562	180	211	261	297	247
0,092	29	L. 1600	SL1P12572	219	261	323	369	302
0,102	34,5	L. 1920	SL1P12582	259	308	381	435	357

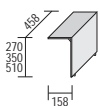

VOLm³	Kg	Piede   Foot	metallo   metal					
0,031	13	H. 270	SL1XP0124	167				
0,038	15,5	H. 350	SL1XP0134	175				
0,054	20	H. 510	SL1XP0144	194				



- Piani posizionabili a terra forniti di piedini regolabili H.10 oppure in appoggio a basi, in questo caso sono forniti di piede di supporto a terra in metallo. Possono essere anche sospesi mediante staffe, in questo caso non vanno posizionati ad un'altezza superiore al metro perché il lato inferiore non è finito.  
 - Free-standing benches, provided with 10 mm-high adjustable feet or a support base. In this case, they are fitted with free-standing metal support feet. They can also be suspended via brackets. In this case, they must not be positioned higher than one metre because the bottom panel is not finished.

codice code	lacc. opaco matt lacq.	essenza cat. 1 wood cat. 1	essenza cat. 2 wood cat. 2	rovere lacc. matt lacq. oak	lacc. lucido glossy lacq.
-------------	------------------------	----------------------------	----------------------------	-----------------------------	---------------------------

**Piani a terra**  
Free-standing benches

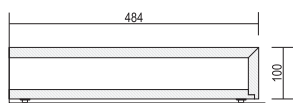
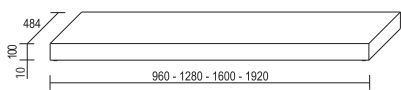

VOLm³	Kg
0,066	13
0,087	17
0,108	21
0,130	24

**P. | D. 484**

L.	SL	250	336	373	387	306
L. 960	SL1P30459	250	336	373	387	306
L. 1280	SL1P30469	292	381	438	454	382
L. 1600	SL1P30479	332	422	498	518	413
L. 1920	SL1P30489	357	468	553	575	459

**Piani sospesi**

La tenuta dei sistemi di fissaggio al muro è garantita dal corretto utilizzo dei tasselli, adeguati al tipo di parete (calcestruzzo, cartongesso, laterizio, ecc.), pertanto l'Azienda non fornisce alcun tipo di tassello e la responsabilità delle operazioni di montaggio è totalmente a carico del cliente.

**Hanging benches**

The right wall-compatible screw plugs (concrete, plasterboard, brick, etc.) must be used to ensure that the mounting system is secured to the wall. Therefore, the company does not supply any screw plugs and the customer is solely responsible for the assembly.

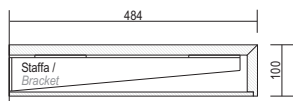
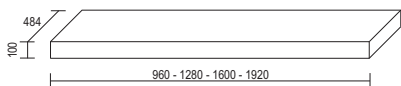

VOLm³	Kg
0,077	16,5
0,099	20
0,131	27
0,153	31

**P. | D. 484**

L.	SL	322	409	445	459	378
L. 960	SL1P31459	322	409	445	459	378
L. 1280	SL1P31469	364	453	510	526	454
L. 1600	SL1P31479	463	552	629	648	544
L. 1920	SL1P31489	486	599	684	706	590

**Piani in appoggio,**  
aggiungere sempre il piede di supporto in metallo nelle altezze desiderate,  
piede disponibile in finitura brown, ottone, titanio o bianco

**Supported benches,**

always add the metal support feet at the desired heights.

The feet are available in a brown, brass, titanium or white finish.

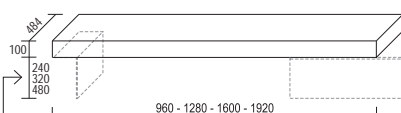

VOLm³	Kg
0,066	13
0,087	17
0,108	21
0,130	24

**P. | D. 484**

L.	SL	250	336	373	387	306
L. 960	SL1P32459	250	336	373	387	306
L. 1280	SL1P32469	292	381	438	454	382
L. 1600	SL1P32479	332	422	498	518	413
L. 1920	SL1P32489	357	468	553	575	459

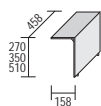

VOLm³	Kg
0,031	13
0,038	15,5
0,054	20

**Piede | Foot**

metallo | metal

H.	SL	167	175	194
H. 270	SL1XP0124	167		
H. 350	SL1XP0134	175		
H. 510	SL1XP0144	194		

- Sono fornite di reggimensola regolabili per il fissaggio al muro. La tenuta dei sistemi di fissaggio al muro è garantita dal corretto utilizzo dei tasselli, adeguati al tipo di parete (calcestruzzo, cartongesso, laterizio, ecc.), pertanto l'Azienda non fornisce alcun tipo di tassello e la responsabilità delle operazioni di montaggio è totalmente a carico del cliente.  
 - They are supplied with adjustable hangers for fastening to the wall. The right wall-compatible screw plugs (concrete, plasterboard, brick, etc.) must be used to ensure that the mounting system is secured to the wall. Therefore, the company does not supply any screw plugs and the customer is solely responsible for the assembly.

**codice  
code**
**lacc. opaco  
mat lacq.**
**essenza cat. 1  
wood cat. 1**
**essenza cat. 2  
wood cat. 2**
**rovere lacc.  
matt lacq. oak**
**lacc. lucido  
glossy lacq.**
**maggiorazione  
luce LED**
**superfici UP  
UP surface**
**surcharge  
LED light**
**Mensole legno**  
 Wooden shelves

Accessoriabili a richiesta con lampada LED ad incasso (luce calda 3000°K), completa di kit di connessione. Capovolgendo la mensola si determina la posizione della luce (lato superiore o inferiore).  
 Attenzione: la gestione del posizionamento del trasformatore sarà a cura del cliente. Il sistema di accensione deve essere collegato ad un interruttore della rete elettrica della stanza.  
 Can be fitted on request with a recessed LED light (3000K warm light). The light is supplied with a connection kit. Flip over the shelf to determine the position of the light (upper or lower side).  
 Please note: It is the customer's responsibility to correctly position the transformer.

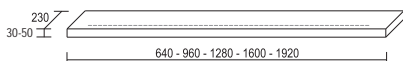

VOLm³ Kg

**Sp. | Th. 30**

0,013 3,3

L. 640 SL1M01231

**54**
**83**
**99**
**105**
**77**

optional

**152**

0,019 4,5

L. 960 SL1M01251

**73**
**110**
**131**
**140**
**104**
**171**

0,025 6

L. 1280 SL1M01261

**91**
**132**
**158**
**170**
**131**
**189**

0,031 7,3

L. 1600 SL1M01271

**107**
**159**
**189**
**204**
**158**
**212**

0,037 8,7

L. 1920 SL1M01281

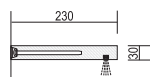
**124**
**184**
**219**
**236**
**185**
**249**

VOLm³ Kg

**Sp. | Th. 50**

0,017 5

L. 640 SL1M02232

**72**
**98**
**117**
**124**
**94**
**152**

0,024 7,3

L. 960 SL1M02252

**94**
**127**
**152**
**160**
**126**
**171**

0,032 9,5

L. 1280 SL1M02262

**115**
**155**
**184**
**196**
**156**
**189**

0,040 11,7

L. 1600 SL1M02272

**137**
**185**
**220**
**234**
**188**
**212**

0,048 14

L. 1920 SL1M02282

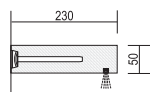
**157**
**214**
**256**
**274**
**220**
**249**

**Mensole vassoio, in metallo finitura brown, bianco, ottone, titanio**  
 Metal tray shelves in a brown, white, brass or titanium finish

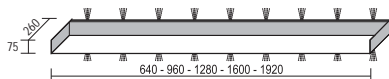
Accessoriabili a richiesta con lampade LED (luce calda 3000°K) inserite sul retro della struttura, complete di kit di connessione. Il sistema di accensione deve essere collegato ad un interruttore della rete elettrica della stanza. Disponibile esclusivamente con luce sia sul lato superiore che inferiore.  
 Can be fitted on request with an LED light (3000K warm light) inserted into the back of the structure. It is supplied with a connection kit. The switch-on system must be connected to a mains switch in the room. The light can only be on the top or the underside.



VOLm³ Kg

**Sp. | Th. 75**

0,023 7,8

L. 640 SL1M04232

metallo | metal

**351**

optional

**146**

0,035 11

L. 960 SL1M04252

**384**
**183**

0,046 14

L. 1280 SL1M04262

**416**
**214**

0,057 17

L. 1600 SL1M04272

**461**
**274**

0,068 20

L. 1920 SL1M04282

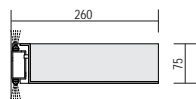
**501**
**305**

ACCOSTAMENTO PANNELLI | PANEL MATCHING

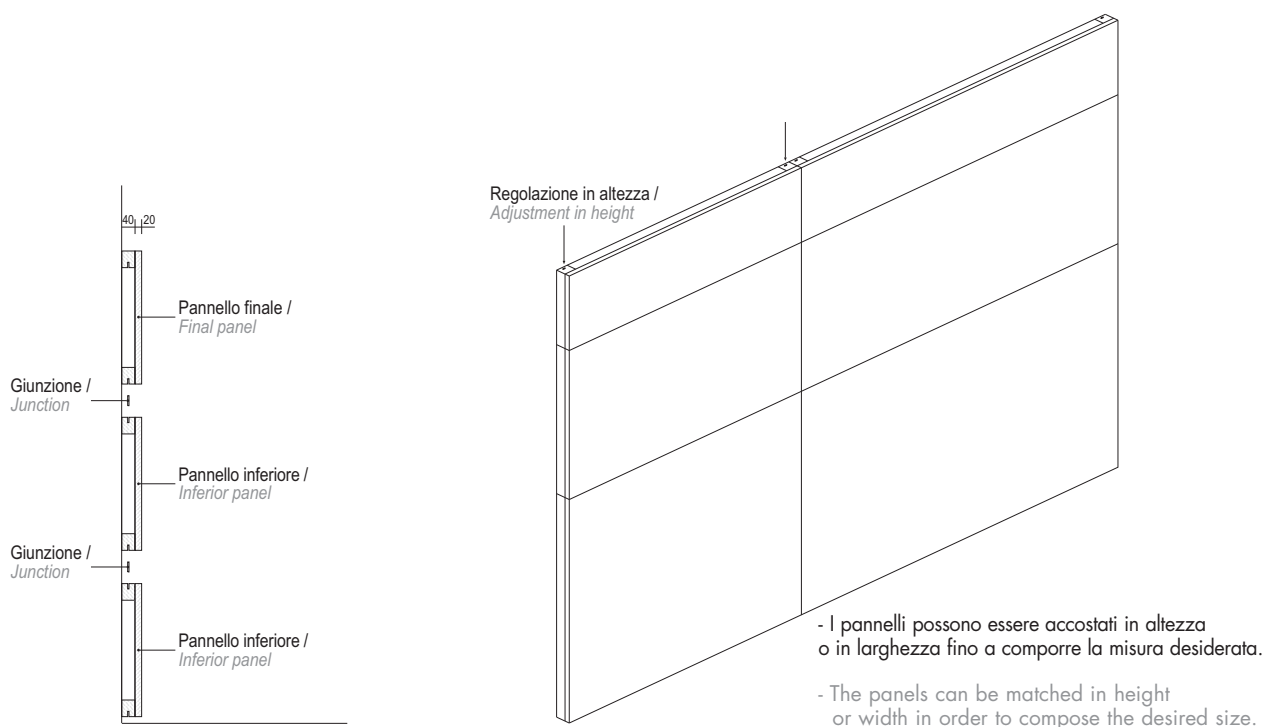

CARATTERISTICHE DIMENSIONALI | DIMENSIONAL CHARACTERISTICS

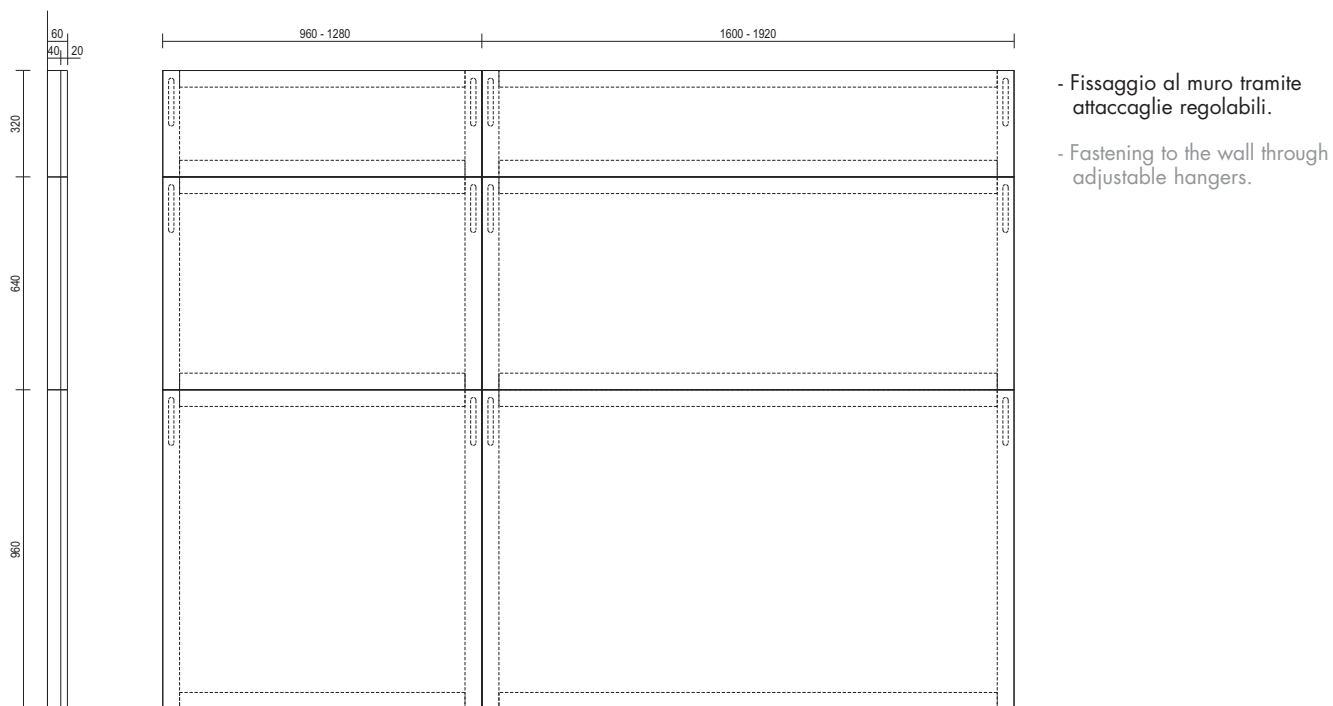

POSIZIONAMENTO MENSOLE | SHELVES POSITIONING

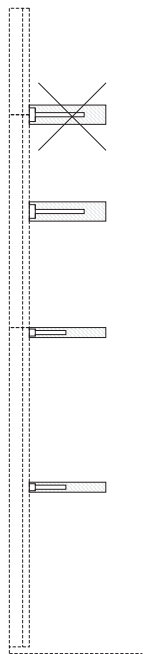

- Le mensole possono essere fissate alle boiserie in ogni posizione tranne al centro tra un pannello e l'altro, utilizzando le attaccaglie fornite di serie.

- The shelves can be fixed to the boiserie in any position except at the centre between one panel and another, using the standard hangers provided.

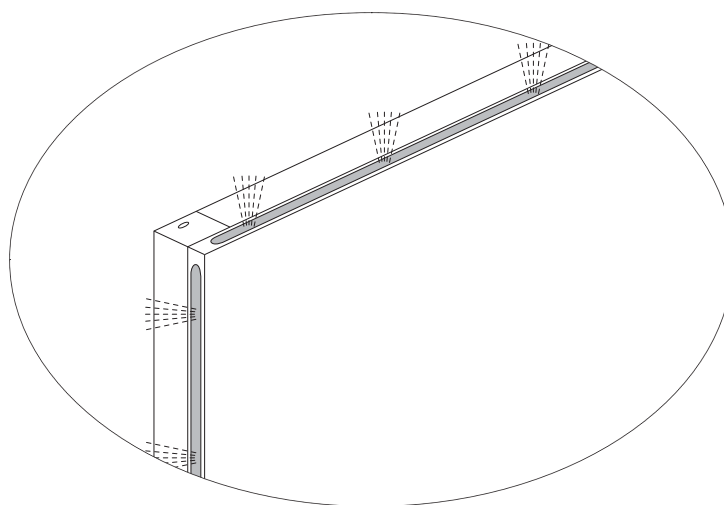

FORO PASSACAVI PER POSIZIONAMENTO TV | CABLE DUCT HOLE FOR TV POSITIONING

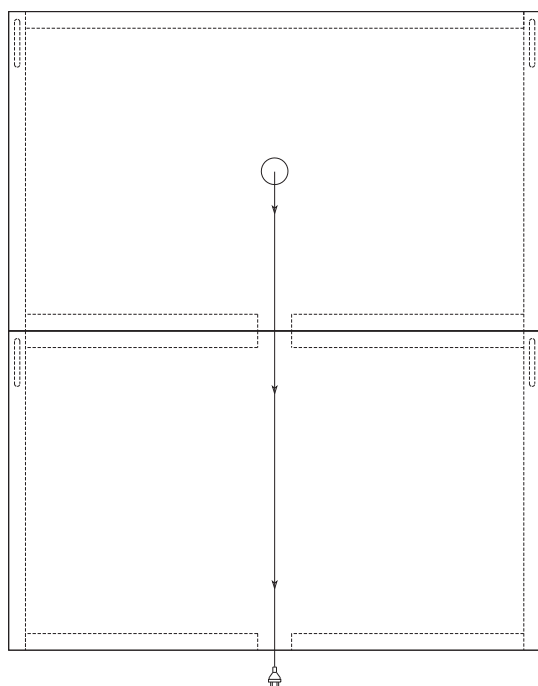

- Il pannello boiserie può essere utilizzato per il posizionamento del tv prevedendo l'aggiunta del FORO CON PASSACAVI (vedi pag. 119). Indicare nell'ordine il suo posizionamento (di serie è previsto al centro del pannello).

- Il passaggio dei cavi può essere gestito direttamente durante il montaggio con dei tagli (vedi istruzioni di montaggio) oppure richiesto e descritto nell'ordine con un sovrapprezzo di **€ 64,00**

- The boiserie panel can be used for positioning the TV by adding the CABLE DUCT HOLE (see page 119). Specify its position in the order (the standard version provides the hole in the middle of the panel).

- The passage of the cables can be managed directly during the assembly by making the necessary cuts (see assembly instructions) or requested and described in the order with a surcharge of **€ 64,00**

**ELETRIFICAZIONE APPARECCHI AUDIO/VIDEO POSIZIONATI INTERNAMENTE ALLE BASI**  
**ELECTRIFICATION OF AUDIO/VIDEO APPLIANCES POSITIONED INSIDE THE BASES**

Sezione frontale | Front section

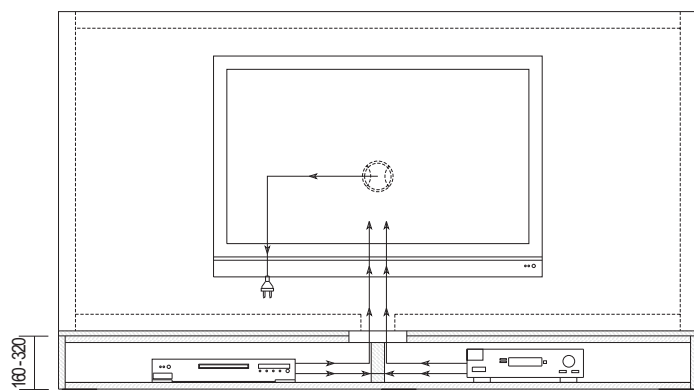

Sezione laterale | Side section

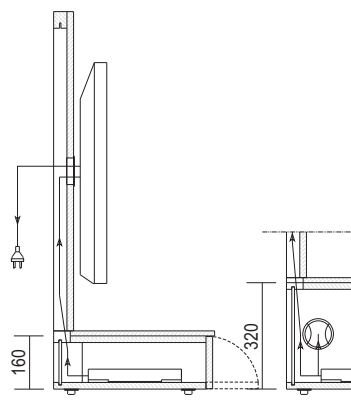

È necessaria una pantografatura sul top e coperchio della base, due fori con passacavi, uno nel divisorio tra i due vani della base H.320 (lavorazioni con maggiorazione); nel caso invece di basi H.160 il divisorio termina prima della schiena e quindi vi è un'apertura utilizzabile per il passaggio dei cavi.

A pantograph machining is necessary on the top and cover of the base, and two cable duct holes must be made, one in the partition between the two compartments of the base h.320 (machining with a surcharge); in case of bases h. 160, the partition ends before the back so there is an opening that can be used for the passage of the cables.

**ELETRIFICAZIONE APPARECCHI AUDIO/VIDEO POSIZIONATI SOPRA LE BASI**  
**ELECTRIFICATION OF AUDIO/VIDEO APPLIANCES POSITIONED ON THE BASES**

Vista frontale | Front view

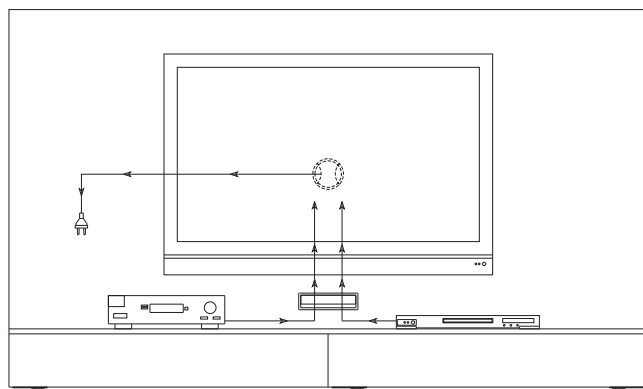

Sezione laterale | Side section

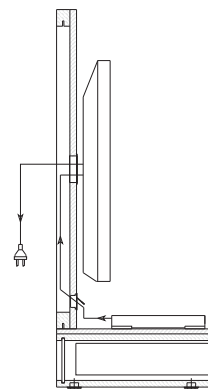

Sono necessari due passacavi sul pannello boiserie, uno sotto vicino agli apparecchi audio/video e uno dietro il TV (lavorazioni con maggiorazione).

Two cable ducts are necessary on the boiserie panel, one below, near the audio/video appliances and one behind the TV (machining with a surcharge).

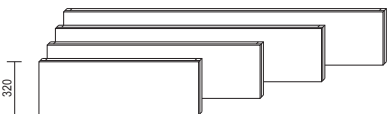
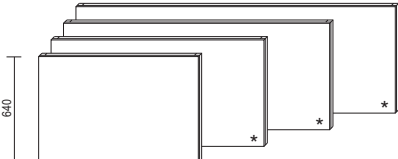
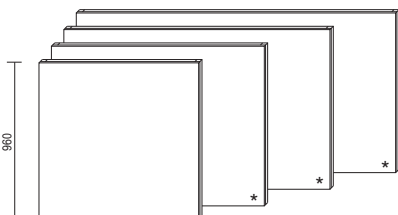
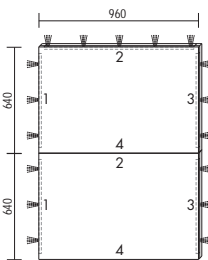
- Prezzo comprensivo di attaccaglie regolabili per il fissaggio del pannello al muro - Price including the adjustable hangers for fastening the panel to the wall		codice	lacc. opaco	essenza cat. 1	essenza cat. 2	rovere lacc.	lacc. lucido		
		code	matt lacq.	wood cat. 1	wood cat. 2	matt lacq. oak	glossy lacq.	superfici UP	UP surface
Pannelli boiserie h. 320 Boiserie panels h. 320									
	VOLm³ Kg	Orizzontale   Horizontal							
	0,036 8,5	L. 960	SL1B20251	<b>156</b>	<b>207</b>	<b>246</b>	<b>251</b>	<b>186</b>	
	0,048 10,5	L. 1280	SL1B20261	<b>181</b>	<b>243</b>	<b>290</b>	<b>297</b>	<b>220</b>	
	0,059 12,5	L. 1600	SL1B20271	<b>208</b>	<b>280</b>	<b>334</b>	<b>344</b>	<b>258</b>	
	0,071 14,5	L. 1920	SL1B20281	<b>233</b>	<b>316</b>	<b>376</b>	<b>388</b>	<b>296</b>	
Pannelli boiserie h.640 alcuni sono posizionabili anche in verticale Boiserie panels h. 640 Some can also be placed in a vertical position									
		* Verticale   Vertical							
		H. 1280	SL1B20236	<b>229</b>	<b>321</b>	<b>383</b>	<b>399</b>	<b>306</b>	
		H. 1600	SL1B20237	<b>268</b>	<b>374</b>	<b>444</b>	<b>464</b>	<b>363</b>	
		H. 1920	SL1B20238	<b>304</b>	<b>424</b>	<b>504</b>	<b>528</b>	<b>418</b>	
	VOLm³ Kg	Orizzontale   Horizontal							
0,068 13	L. 960	SL1B20253	<b>197</b>	<b>274</b>	<b>327</b>	<b>339</b>	<b>258</b>		
0,090 16,5	L. 1280	SL1B20263	<b>229</b>	<b>321</b>	<b>383</b>	<b>399</b>	<b>306</b>		
0,112 20	L. 1600	SL1B20273	<b>268</b>	<b>374</b>	<b>444</b>	<b>464</b>	<b>363</b>		
0,133 23,5	L. 1920	SL1B20283	<b>304</b>	<b>424</b>	<b>504</b>	<b>528</b>	<b>418</b>		
Pannelli boiserie h.960 alcuni sono posizionabili anche in verticale Boiserie panels h. 960 Some can also be placed in a vertical position									
		* Verticale   Vertical							
		H. 1280	SL1B20256	<b>278</b>	<b>400</b>	<b>476</b>	<b>499</b>	<b>394</b>	
		H. 1600	SL1B20257	<b>328</b>	<b>466</b>	<b>555</b>	<b>584</b>	<b>467</b>	
		H. 1920	SL1B20258	<b>375</b>	<b>530</b>	<b>631</b>	<b>666</b>	<b>542</b>	
	VOLm³ Kg	Orizzontale   Horizontal							
0,100 18	L. 960	SL1B20255	<b>240</b>	<b>341</b>	<b>405</b>	<b>423</b>	<b>330</b>		
0,132 23	L. 1280	SL1B20265	<b>278</b>	<b>400</b>	<b>476</b>	<b>499</b>	<b>394</b>		
0,164 28	L. 1600	SL1B20275	<b>328</b>	<b>466</b>	<b>555</b>	<b>584</b>	<b>467</b>		
0,196 33	L. 1920	SL1B20285	<b>375</b>	<b>530</b>	<b>631</b>	<b>666</b>	<b>542</b>		
Luci LED perimetrali (luce calda 3000°K) Perimetral LED light (3000K warm light)									
<p>La luce led è posizionabile su 1, 2, 3 o tutti e 4 i lati della boiserie, specificandolo in conferma d'ordine. Per il calcolo corretto sommare il prezzo delle luci led nelle misure volute + il prezzo dell'alimentatore adatto.</p> <p>The LED light can be fitted on 1, 2, 3 or all 4 sides of the wooden panelling, and this must be specified when confirming the order. To work out the correct price, add the price of the LED lights in the desired sizes and the price of the suitable power supply.</p>		Luce LED   LED light							
		L. 320 - 3 W	SL1XL0320	<b>94</b>					
	L. 640 - 7 W	SL1XL0640	<b>110</b>						
	L. 960 - 10 W	SL1XL0960	<b>126</b>						
	L. 1280 - 13 W	SL1XL1280	<b>142</b>						
	L. 1600 - 16 W	SL1XL1600	<b>156</b>						
	L. 1920 - 22 W	SL1XL1920	<b>169</b>						
	<b>+</b>								
	Alimentatore   Power supply								
	15 W	SL1XA0480	<b>22</b>						
	20 W	SL1XA0960	<b>26</b>						
	30 W	SL1XA1600	<b>45</b>						
ES. CALCOLO ALIMENTATORE   E.g. POWER SUPPLY CALCULATION 640 (7W) + 960 (10W) + 640 (7W) = 24W -> N.1 alimentatore   power supply 30W 640 (7W) + 640 (7W) = 14W -> N.1 alimentatore   power supply 15W									

ESEMPI DI UTILIZZO  
EXAMPLE OF COMPOSITIONS

Nel caso di accostamento laterale di pannelli l'altezza totale (data dalla somma dei pannelli e dei profili) deve risultare uguale.  
When placing panels next to one another, the total height (the panels and profiles added together) must be equal.

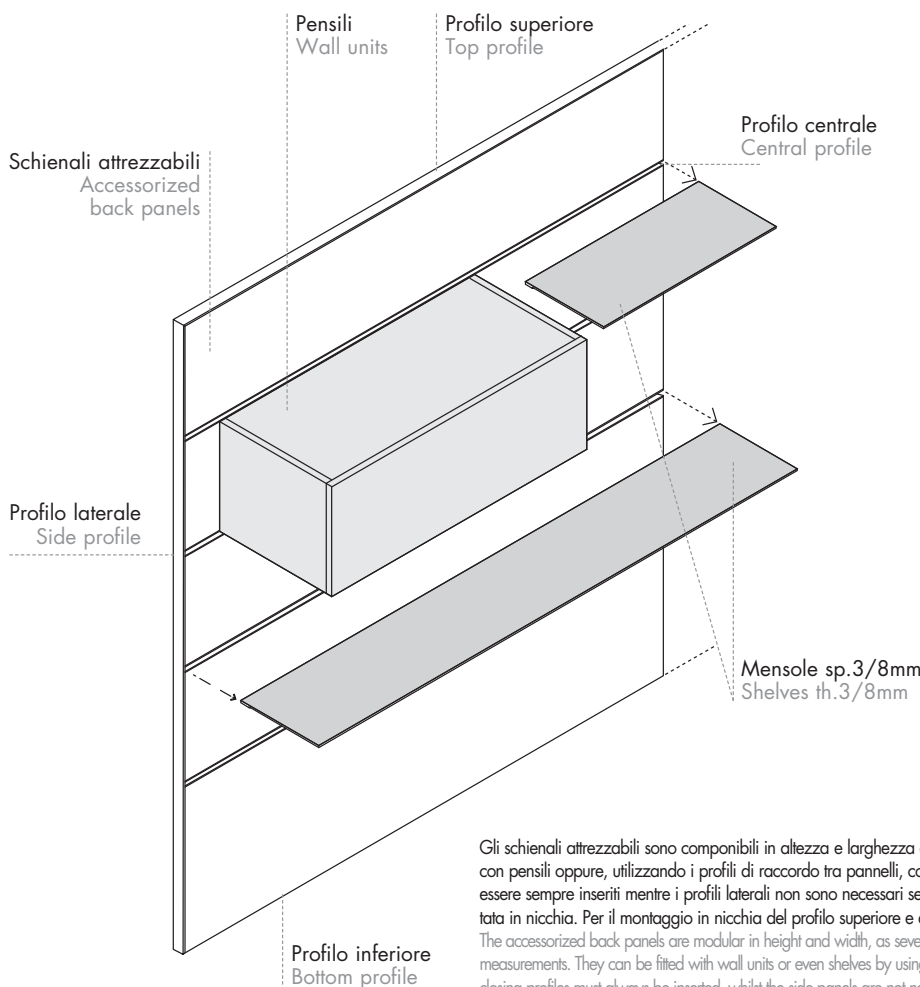
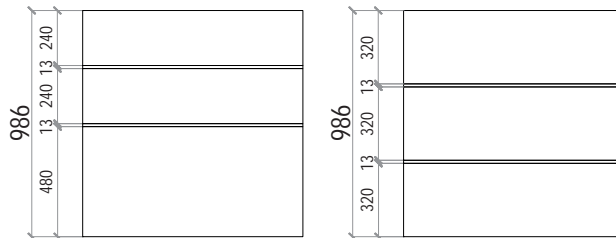

Attenzione! Non è possibile il posizionamento dei pensili nell'ultimo pannello superiore. Il sistema di aggancio dei pensili allo schienale è quello standard.  
Please note! Wall units cannot be positioned in the uppermost panel. A standard mounting system is used to secure the wall units to the back panel.

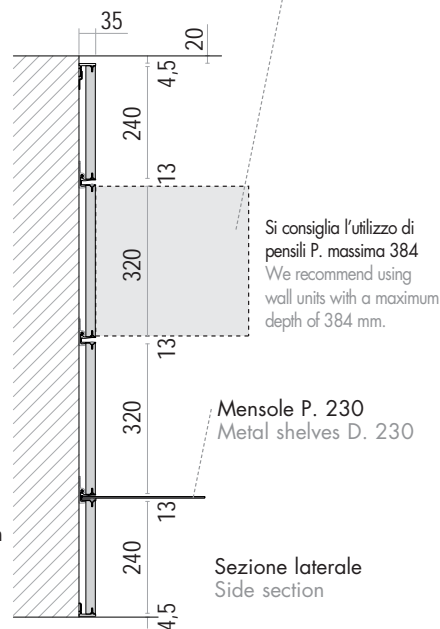

Gli schienali attrezzabili sono componibili in altezza e larghezza accostando più moduli nelle misure scelte. Sono attrezzabili con pensili oppure, utilizzando i profili di raccordo tra pannelli, con mensole. I profili di chiusura superiore ed inferiore devono essere sempre inseriti mentre i profili laterali non sono necessari se si accostano più moduli oppure se la pannellatura va montata in nicchia. Per il montaggio in nicchia del profilo superiore e di quello laterale è necessario uno spazio minimo di 20 mm. The accessorized back panels are modular in height and width, as several modules can be placed alongside each other in the chosen measurements. They can be fitted with wall units or even shelves by using the connecting profiles between the panels. The top and bottom closing profiles must always be inserted, whilst the side panels are not needed if more than one module has been fitted together, or if the panelling is to be mounted in a niche. In order to mount the upper and side panel in a niche, a minimum space of 20 mm is required.

! Non è possibile l'inserimento di passacavi e luci led negli schienali attrezzabili. | Cable glands and LED lights cannot be fitted onto accessorized back panels.

- Mensola utilizzabile esclusivamente in abbinamento a schienali attrezzabili e disponibile in finitura brown, bianco, ottone e titanio.  
- A shelf can only be used in combination with an accessorized back panel. Shelves are available in a brown, white, brass or titanium finish.

codice	metallo
code	metal

Mensola in metallo, per schienali attrezzabili  
Metal shelf, for accessorized back panels

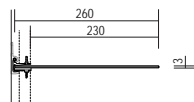
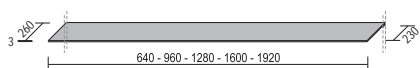

VOLm³	Kg	Sp.   Th. 3		
0,008	4,7	L. 640	SL1M05232	<b>137</b>
0,011	7,3	L. 960	SL1M05252	<b>164</b>
0,015	9,3	L. 1280	SL1M05262	<b>199</b>
0,019	11,3	L. 1600	SL1M05272	<b>231</b>
0,022	13,6	L. 1920	SL1M05282	<b>247</b>

# SCHIENALI ATTREZZABILI | ACCESSORIZED BACK PANELS

- Prezzo comprensivo di profili con sistema di fissaggio del pannello al muro e di profili laterali. Profili disponibile in finitura brown, bianco, ottone e titanio. - Price including the profiles with a mounting system for securing the panel to the wall and the side profiles. The profiles are available in a brown, white, titanium or brass finish.		codice	lacc. opaco	essenza cat. 1	essenza cat. 2	rovere lacc.	lacc. lucido	materico		
		code	matt lacq.	wood cat. 1	wood cat. 2	matt lacq. oak	glossy lacq.	textured finish		
<b>Schienali attrezzabili H. 240</b> Accessorized back panels H. 240										
	VOLm³	Kg	<b>H. 240</b>							
	0,017	4,5	L. 960	SL1B30150	133	151	164	169	152	114
	0,022	5,7	L. 1280	SL1B30160	148	167	188	195	174	121
	0,028	7	L. 1600	SL1B30170	171	196	222	229	205	137
	0,033	8,2	L. 1920	SL1B30180	194	216	246	254	235	156
<b>Schienali attrezzabili H. 320</b> Accessorized back panels H. 320										
	VOLm³	Kg	<b>H. 320</b>							
	0,022	5,5	L. 960	SL1B30151	158	179	199	207	186	129
	0,029	7,2	L. 1280	SL1B30161	179	198	228	237	219	139
	0,035	8,8	L. 1600	SL1B30171	206	227	265	277	254	154
	0,042	10,3	L. 1920	SL1B30181	232	256	301	314	292	173
<b>Schienali attrezzabili H. 480</b> Accessorized back panels H. 480										
	VOLm³	Kg	<b>H. 480</b>							
	0,031	7,5	L. 960	SL1B30152	182	206	234	243	220	144
	0,041	9,7	L. 1280	SL1B30162	209	229	267	279	262	156
	0,051	12	L. 1600	SL1B30172	239	259	308	323	303	171
	0,061	14,2	L. 1920	SL1B30182	269	296	355	373	348	189
<b>Schienali attrezzabili H. 640</b> Accessorized back panels H. 640										
	VOLm³	Kg	<b>H. 640</b>							
	0,041	9,5	L. 960	SL1B30153	227	255	296	310	287	171
	0,054	12,7	L. 1280	SL1B30163	266	292	349	368	343	188
	0,067	15,5	L. 1600	SL1B30173	304	332	402	425	401	207
	0,080	18,4	L. 1920	SL1B30183	345	375	463	490	462	235
<b>Schienali attrezzabili H. 960</b> Accessorized back panels H. 960										
	VOLm³	Kg	<b>H. 960</b>							
	0,060	13,8	L. 960	SL1B30155	273	305	359	377	353	197
	0,079	18,2	L. 1280	SL1B30165	322	354	431	455	424	220
	0,098	22,5	L. 1600	SL1B30175	368	405	496	525	499	242
	0,118	26,7	L. 1920	SL1B30185	421	454	571	606	575	280
<b>Mensola in legno sp. 8 mm, per schienali attrezzabili</b> Wooden shelf th. 8 mm, for accessorized back panels										
			<b>Sp.   Th. 8</b>							
	0,008	1,5	L. 640	SL1M00231	34	60	79	86	57	25
	0,011	1,4	L. 960	SL1M00251	52	85	116	126	85	33
	0,015	2,5	L. 1280	SL1M00261	65	104	146	159	106	38
	0,019	2,8	L. 1600	SL1M00271	83	134	186	202	138	49
	0,022	3,2	L. 1920	SL1M00281	96	158	219	238	162	58



# PORTA TV SOSPESO CON MENSOLE | SUSPENDED TV STAND WITH SHELVES

- Su richiesta disponibile con copriforo passacavi Ø 80 e lampada led optional (luce calda 3000°K)  
 - On request, available with hole-cover dia.80 and led lamp optional (3000K warm light)

codice code	lacc. opaco matt lacq.	essenza cat. 1 wood cat. 1	essenza cat. 2 wood cat. 2	rovere lacc. matt lacq. oak	lacc. lucido glossy lacq.
					superfici UP UP surface

Porta TV sospeso - portata Kg. 80  
 Suspended TV stand - capacity kg. 80

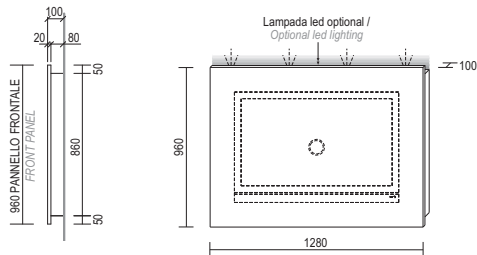

Porta TV   TV stand	SL1P20165	<b>368</b>	<b>465</b>	<b>549</b>	<b>579</b>	<b>501</b>
Lampada led optional Optional LED light		<b>166</b>	<b>166</b>	<b>166</b>	<b>166</b>	<b>166</b>
Copriforo   Hole cover optional	A99011	<b>20</b>	<b>20</b>	<b>20</b>	<b>20</b>	<b>20</b>
Lavorazione per copriforo Machining for hole cover		<b>49</b>	<b>49</b>	<b>49</b>	<b>49</b>	<b>49</b>

VOL. m<sup>3</sup> 0,185    kg 23

Pannello sospeso con mensole  
 Suspended panel with shelves

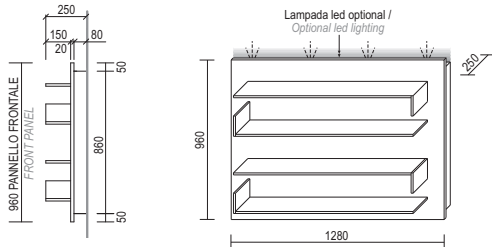

Pannello c/mensole   Panel w/shelves	SL1P20265	<b>604</b>	<b>837</b>	<b>996</b>	<b>1057</b>	<b>839</b>
Lampada led optional Optional LED light		<b>166</b>	<b>166</b>	<b>166</b>	<b>166</b>	<b>166</b>

VOL. m<sup>3</sup> 0,231    kg 29,5

Anta scorrevole per porta TV sospeso con mensole  
 Sliding door for suspended TV stand with shelves

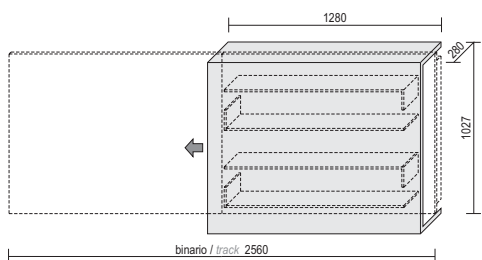

Anta scorr.   Sliding door	SL1A05265	<b>574</b>	<b>763</b>	<b>908</b>	<b>951</b>	<b>767</b>
----------------------------	-----------	------------	------------	------------	------------	------------





VOL. m<sup>3</sup> 0,102    kg 26



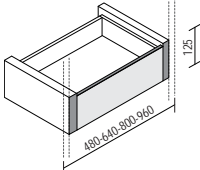
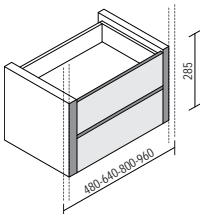

DESCRIZIONE   DESCRIPTION			prezzo per elemento price for element
Riduzione elementi montati con frontali legno in Reduction of assembled elements, with wooden front, in	Larghezza * Width *		189
Riduzione elementi montati con frontali legno in Reduction of assembled elements, with wooden front, in	Altezza Height		189
Riduzione elementi montati con frontali legno in Reduction of assembled elements, with wooden front, in	Profondità * Depth *		189
Riduzione mensole legno sp. 30-50 mm in Larghezza o Profondità (dim. minima in P. 190 mm) Reduction of wooden shelves th. 30-50 mm in Width or Depth (minimum dim. in D. 190 mm)			58
Riduzione piani sp. 50 mm in Larghezza o Profondità Reduction of benches th. 50 mm in Width or Depth			64
Piani sp. 100 mm su misura in Larghezza - verificare con i nostri uffici vendite fattibilità e prezzo Custom-made benches th. 100 mm in Width - feasibility and price to be checked with our Sales Department			prezzo da verificare price to be checked
Riduzione top legno sp. 15 mm in Larghezza o Profondità Reduction of wooden tops th. 15 mm in Width or Depth			52
Taglio con scanso top legno sp. 15 mm (scanso ad U o a L) Undercut of wooden tops th. 15 mm (U- or L-undercut)			127
Riduzione top Laminam® sp. 5,5 mm in Larghezza o Profondità Reduction of Laminam® tops th. 5,5 mm in Width or Depth		maggiorazione surcharge	+ 30 %
Riduzione pannelli boiserie sp. 60 mm in Larghezza o Altezza Reduction of boiserie panels th. 60 mm in Width or Height			108
Riduzione schienali attrezzabili sp.35 in Larghezza o Altezza (i tempi di consegna si allungano a 6/7 sett.) Reduction of accessorized back panels th.35 in Width or Height (delivery time is extended to 6/7 weeks)			98
Cd. SL1X23139 larghezza max. 300, min. 30 mm lunghezza max. 3230 mm max. width 300, min. 30 mm max. length 3230 mm	Fascia di tamponamento in lacc. opaco Infill panel in matt lacq.	prezzo al ml price per MTL	58
	Fascia di tamponamento in essenza cat. 1 Infill panel in wood finish cat. 1	prezzo al ml price per MTL	91
	Fascia di tamponamento in essenza cat. 2 Infill panel in wood finish cat. 2	prezzo al ml price per MTL	103
	Fascia di tamponamento in lacc. lucido e superfici up Infill panel in glossy lacq. and up surface	prezzo al ml price per MTL	85
Laccato a campione (comunicare codice RAL di riferimento) Lacquer as per the sample (specify reference RAL code)		maggiorazione surcharge	+ 20 %
Laccatura maniglia Slim (comunicare codice RAL di riferimento) Slim handle lacquering (specify reference RAL code)			34
Sovrapprezzo per coppia guide ad estrazione totale Surcharge for a pair of full-extension pull-out runners		P.   D. 484	33
Riduzione ripiani vetro in Larghezza o Profondità Reduction of glass shelves in Width or Depth			64
Riduzione maniglia Reduction of handle			52

Elementi particolari che non si possono modificare: cassetti, ante vetro, elementi pensili a giorno, cubotti in legno e metallo, porta tv sospeso, materiale in metallo. Inoltre non si possono fare lavorazioni in curvo. Eventuali lavorazioni, non previste nel presente listino, dovranno essere preventivamente richieste ai nostri uffici vendite.  
Particular elements that cannot be modified: drawers, glass doors, open wall units, wooden or metal cubes, suspended tv stand, metal element. Furthermore, machining cannot be done on curved elements. Any special working not included in this price list has to be checked beforehand with our sales office.

\* Attenzione! Aggiungere il sovrapprezzo relativo ai ripiani vetro se sono presenti nell'elemento. Aggiungere il sovrapprezzo della riduzione maniglia se presente.

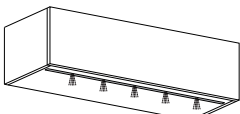
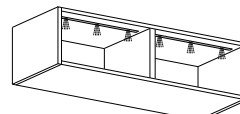
\* Attention! Add the surcharge for the glass shelves if they are present in the element. Add the surcharge for the handles if they are present.

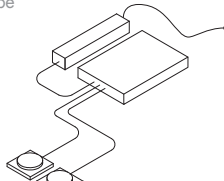
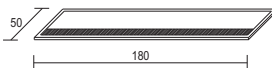
<b>CASSETTI INTERNI</b> retro cestoni H. 480 e ante battenti - P. 480 <b>INTERNAL DRAWERS</b> behind the 480 mm-high deep drawers and 480 mm-deep hinged doors		codice code	lacc. opaco matt lacq.	materico textured finish		
1 cassetto interno 1 internal drawer  		VOLm <sup>3</sup> Kg 0,034 5,5 0,044 6 0,055 6,7 0,065 7,5	<b>P.   D. 480</b> L. 480 L. 640 L. 800 L. 960	SL1CI0421 SL1CI0431 SL1CI0441 SL1CI0451	105 117 128 137	101 111 121 129
2 cassetti interni 2 internal drawers  		VOLm <sup>3</sup> Kg 0,067 11 0,087 12,5 0,108 13,7 0,128 15	<b>P.   D. 480</b> L. 480 L. 640 L. 800 L. 960	SL1CI0422 SL1CI0432 SL1CI0442 SL1CI0452	210 233 255 273	201 221 241 258
<b>BRACCETTI A FILO</b> <b>WIRE HINGES</b>   <p>Possono essere impiegati solo su ribalte legno con apertura verso il basso, non disponibili per H. 160. They can only be used on downwards-opening wooden flaps and are not available in the 160 mm height.</p>		<b>Per frontali   For front</b> L. 640 H. 240  Tutte le altre misure All other dimensions  L. 1600-1920 H. 480		1 braccetto 1 wire hinge  2 braccetti 2 wire hinges  3 braccetti 3 wire hinges	maggiorazione surcharge  40  80  120	
<b>APPENDIABITI ESTRAIBILE</b> in acciaio cromato <b>EXTRACTABLE CLOTHES HANGERS</b> in chrome steel   <p>Può essere impiegato su ripiani interni di pensili P. 384 / 480 Can be used on the internal shelves of the 384/480 mm-deep wall units.</p>		<b>P.   D. 384</b> P. 290 x H. 50  <b>P.   D. 480</b> P. 360 x H. 50		SL1XAE484  SL1XAE580	26  29	
<b>STREAP LED:</b> luce calda 3000°K - bobina da 5 mt con alimentatore incluso <b>LED STRIP:</b> 3000K warm light - 5-metre coil with power supply included.   <p>Da utilizzare esternamente nella parte inferiore di composizioni composte da più basi (il taglio in lunghezza e l'applicazione del led con autoadesivo sarà a cura del cliente). To be used externally on the bottom of compositions consisting of multiple base units (the length will be pre-cut and the self-adhesive applied by the client).</p>		L. 5 mt		SL1XLB050	175	

	codice code	prezzo price
<p><b>LUCE LED:</b> luce calda 3000°K. Per il calcolo corretto sommare il prezzo delle luci led nelle misure volute + il prezzo dell'alimentatore adatto. Attenzione: la gestione del posizionamento dell'alimentatore sarà a cura del cliente. Il sistema di accensione deve essere collegato ad un interruttore della rete elettrica della stanza.</p> <p><b>LED LIGHT:</b> 3000K warm light. To work out the correct price, add the price of the LED lights in the desired sizes and the price of the suitable power supply. Please note: It is the customer's responsibility to correctly install the power pack. The switch-on system must be connected to a mains switch in the room.</p>		
<p>Luce led incassata, completa di schermo protettivo sconsigliamo l'applicazione sui vani interni delle basi ed elementi in quanto sono presenti sul coperchio sistemi di regolazione Built-in LED light with a protective screen. We do not recommend affixing the light onto the internal compartments of the base units and elements, as they will be on the lid of the adjustment systems.</p>		
 <p>Esterna ai pensili: specificare se posizionamento superiore o inferiore Outside the wall units: specify whether to position on the top or bottom.</p>		
 <p>Interna ai pensili: per le dimensioni dei vani interni verificare nella pagina delle scocche vuote Inside the wall units: for the dimensions of the internal compartments, check the empty bodies page.</p>		
	Luce LED per vano   LED light for unit	
	L. 320 - 3 W	SL1XL0320 <b>94</b>
	L. 480 - 5 W	SL1XL0480 <b>103</b>
	L. 640 - 7 W	SL1XL0640 <b>110</b>
	L. 800 - 9 W	SL1XL0800 <b>119</b>
	L. 960 - 10 W	SL1XL0960 <b>126</b>
	L. 1280 - 13 W	SL1XL1280 <b>142</b>
	L. 1600 - 16 W	SL1XL1600 <b>156</b>
	L. 1920 - 22 W	SL1XL1920 <b>169</b>
	<b>+</b>	
	Alimentatore   Power supply	
	15 W	SL1XA0480 <b>22</b>
	20 W	SL1XA0960 <b>26</b>
	30 W	SL1XA1600 <b>45</b>
<p><b>KIT RICARICA WIRELESS INVISIBILE</b> adatto per qualsiasi smartphone dotato di ricevitore o con opportuna cover (per l'elenco completo degli smartphone compatibili: <a href="http://www.qinside.biz/en/support/qi-enabled-phones-2017">http://www.qinside.biz/en/support/qi-enabled-phones-2017</a>) <b>INVISIBLE WIRELESS CHARGING</b> suitable for any smartphone with a receiver or suitable cover (for the full list of compatible smartphones, visit: <a href="http://www.qinside.biz/en/support/qi-enabled-phones-2017">http://www.qinside.biz/en/support/qi-enabled-phones-2017</a>)</p> <p>Comprensivo di alimentatore. Posizionabile sul top in legno sp. 15 mm di basi e pensili (specificare l'esatto posizionamento e quindi verificare con i nostri uffici vendite fattibilità e prezzo). Il sistema di accensione deve essere collegato ad un interruttore della rete elettrica della stanza. Power supply included. Can be placed on the 15 mm-thick wooden tops of base units and wall units (specify the exact position and then check with our sales department for a price and to see if this is feasible). The switch-on system must be connected to a mains switch in the room.</p>		
		
	A99020	<b>231</b>
<p><b>KIT AUDIO BLUETOOTH™ INVISIBILE</b> dispositivo audio e stereo completamente celato all'interno dei mobili governabile mediante modulo bluetooth™ completo di n. 2 autopardanti a contatto, amplificatore e alimentatore. <b>INVISIBLE BLUETOOTH™ AUDIO</b> an audio and stereo device, completely concealed within the cabinet. Can be managed via a Bluetooth™ module and comes with 2 Bluetooth™ speakers, an amplifier and a power pack.</p> <p>Posizionabile su boiserie sp. 60 mm, mediacenter e piani sp. 100. Il sistema di accensione deve essere collegato ad un interruttore della rete elettrica della stanza. Can be placed on 60 mm-thick wooden panelling, mediacenter and 100 mm-thick benches. The switch-on system must be connected to a mains switch in the room.</p>		
		
	A99021	<b>518</b>
<p><b>Passacavi   Cable duct</b></p>		
		
	Bianco   White	A99013 <b>48</b>
	Nero   Black	A99012 <b>48</b>
	Lavorazione per passacavi Machining for cable duct	<b>49</b>
	Lavorazione per passacavi su basi Machining for cable duct on bases	<b>84</b>
<p><b>Copri foro   Hole cover</b></p>		
		
	Grigio   Grey	A99011 <b>20</b>
	Lavorazione per copriforo Machining for hole cover	<b>49</b>
	Lavorazione per copriforo su basi Machining for hole cover on bases	<b>84</b>



DALL'AGNESE SLIM

ATTENZIONE: indicare il verso d'apertura (dx o sx) in corrispondenza delle ante / ATTENTION: specify the opening direction (rh or lh) for the doors.  
 Specificare il tipo di frontale - CA: cassetto - CE: cestone - AL: anta legno battente - AV: anta vetro battente -  $\curvearrowright$ : ribalta verso l'alto -  $\curvearrowleft$ : ribalta verso il basso  
 Specify the type of front - CA: drawer - CE: deep drawer - AL: wooden hinged door - AV: glass hinged door -  $\curvearrowright$ : flap-door opening upward -  $\curvearrowleft$ : flap-door opening downward

Cliente / Customer: \_\_\_\_\_  
 Provincia-Stato / Province-State: \_\_\_\_\_  
 Data / Date: \_\_\_\_\_  
 Riferimento / Reference: \_\_\_\_\_  
 Consegna / Delivery: \_\_\_\_\_

	l. opaco mat. lacq.	essenza wood	rovere l. mat. l. oak, glossy l.	lucido-UP mat. l. oak, glossy l., UP
Struttura basi Base structures	<input type="checkbox"/>	<input type="checkbox"/>	<input type="checkbox"/>	<input type="checkbox"/>
Struttura pensili Wall unit structures	<input checked="" type="checkbox"/>	9003	<input type="checkbox"/>	<input type="checkbox"/>
Frontali legno Wood fronts	<input type="checkbox"/>	<input type="checkbox"/>	<input type="checkbox"/>	<input checked="" type="checkbox"/>
Top Tops	<input checked="" type="checkbox"/>	9003	Altro / other:	<input type="checkbox"/>
Mensole Shelves	<input checked="" type="checkbox"/>	petrolite	Tipologia / Type:	<input type="checkbox"/>
Piani Benches	<input checked="" type="checkbox"/>	petrolite	Tipologia / Type:	<input type="checkbox"/>
Boiserie sp. 60 Boiserie panels	<input checked="" type="checkbox"/>	9003	Tipologia / Type:	<input type="checkbox"/>
Porta TV sospeso Susp. TV stand	<input type="checkbox"/>	<input type="checkbox"/>	<input type="checkbox"/>	<input type="checkbox"/>
Pannello c/ mensole Panel w/ shelves	<input type="checkbox"/>	<input type="checkbox"/>	<input type="checkbox"/>	<input type="checkbox"/>
Anta scorri porta tv Sliding door TV stand	<input type="checkbox"/>	<input type="checkbox"/>	<input type="checkbox"/>	<input type="checkbox"/>
El. pensili a giorno Open wall units	<input type="checkbox"/>	<input checked="" type="checkbox"/>	petrolite	<input type="checkbox"/>
El. in metallo Metal elements	<input type="checkbox"/>	<input checked="" type="checkbox"/>	petrolite	<input type="checkbox"/>
Schierati attrezzabili Accessorized back panels	<input type="checkbox"/>	<input type="checkbox"/>	<input type="checkbox"/>	<input type="checkbox"/>

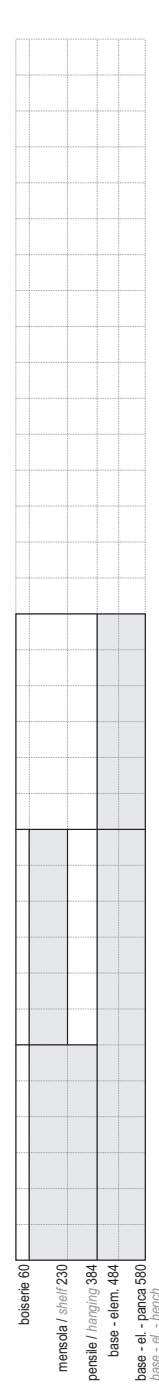
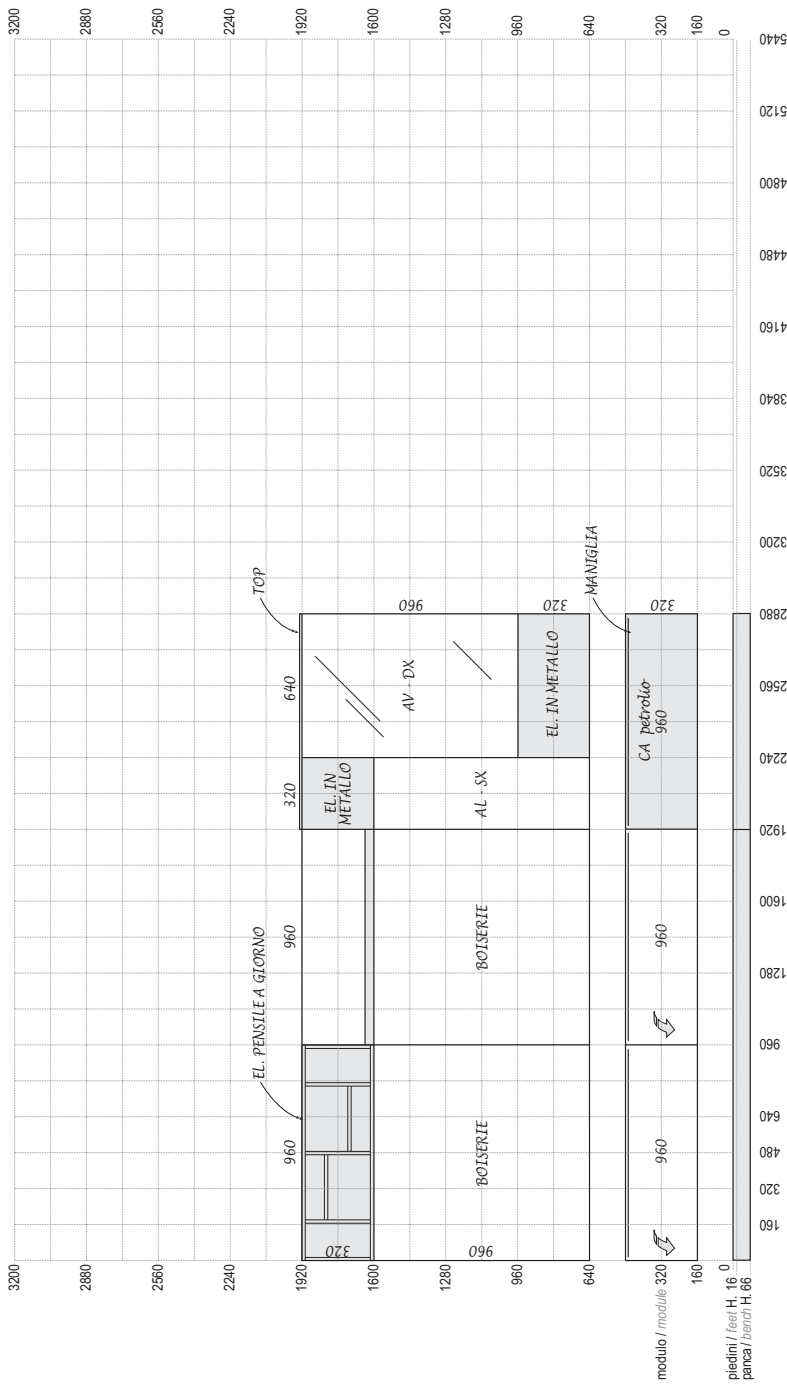

Note / Notes

Maniglie / Handles

Apertura "push and pull" / "Push and pull" opening  
 Apertura con maniglia - specificare tipologia e finitura /  
 Opening with handle - specify type and finish:  
 Maniglia Slim - bianca  
 Slim handle - white

Frontali vetro / Glass fronts paris

Telaio Slim - finitura / Slim Frame - finish:  
 bianco / white  brown  
 Tipologia vetro / Glass type: **BIANCO**  
 Telaio UP brown - vetro trasparente grigio / UP brown frame - grey transparent glass





**# COMP 100** L. 2880 H. 1950 P./D. 484 (pag. 9)  
 Finiture come in foto | Finishes as in photo € 3.776,00  
 Tutta la composizione in lacc. opaco | Whole composition in matt lacq. finish € 3.284,00



**# COMP 101** L. 3200 H. 2150 P./D. 484 (pag. 15)  
 Finiture come in foto | Finishes as in photo € 3.352,00  
 Tutta la composizione in lacc. opaco | Whole composition in matt lacq. finish € 2.725,00



**# COMP 102** L. 3840 H. 2200 P./D. 484 (pag. 21)  
 Finiture come in foto | Finishes as in photo € 3.226,00  
 Tutta la composizione in lacc. opaco | Whole composition in matt lacq. finish € 3.030,00



**# COMP 103** L. 2240 H. 2215 P./D. 484 (pag. 27)  
 Finiture come in foto | Finishes as in photo € 2.085,00  
 Tutta la composizione in lacc. opaco | Whole composition in matt lacq. finish € 2.085,00



**# COMP 104** L. 3840 H. 2340 P./D. 484 (pag. 31)  
 Finiture come in foto | Finishes as in photo € 5.099,00  
 Tutta la composizione in lacc. opaco | Whole composition in matt lacq. finish € 4.349,00



**# COMP 87** L. 3520 H. 2111 P./D. 484 (pag. 37)  
 Finiture come in foto | Finishes as in photo € 4.432,00  
 Tutta la composizione in lacc. opaco | Whole composition in matt lacq. finish € 3.728,00



**# COMP 88** L. 3840 H. 2271 P./D. 484 (pag. 43)  
 Finiture come in foto | Finishes as in photo € 4.802,00  
 Tutta la composizione in lacc. opaco | Whole composition in matt lacq. finish € 4.540,00



**# COMP 105** L. 3840 H. 1900 P./D. 484 (pag. 49)  
 Finiture come in foto | Finishes as in photo € 4.587,00  
 Tutta la composizione in lacc. opaco | Whole composition in matt lacq. finish € 3.607,00



**# COMP 89** L. 3840 H. 2111 P./D. 484 (pag. 55)  
 Finiture come in foto | Finishes as in photo € 4.802,00  
 Tutta la composizione in lacc. opaco | Whole composition in matt lacq. finish € 4.802,00



**# COMP 106** L. 3200 H. 2560 P./D. 484 (pag. 61)  
 Finiture come in foto | Finishes as in photo € 4.793,00  
 Tutta la composizione in lacc. opaco | Whole composition in matt lacq. finish € 4.267,00



**# COMP 107** L. 2880 H. 1871 P./D. 484 (pag. 69)  
 Finiture come in foto | Finishes as in photo € 3.292,00  
 Tutta la composizione in lacc. opaco | Whole composition in matt lacq. finish € 2.715,00



**# COMP 62** L. 3840 H. 2350 P./D. 484 (pag. 75)  
 Finiture come in foto | Finishes as in photo € 5.593,00  
 Tutta la composizione in lacc. opaco | Whole composition in matt lacq. finish € 4.625,00



**# COMP 108** L. 2560 H. 2200 P./D. 384 (pag. 81)  
 Finiture come in foto | Finishes as in photo € 2.618,00  
 Tutta la composizione in lacc. opaco | Whole composition in matt lacq. finish € 2.422,00



**# COMP 109** L. 4800 H. 2150 P./D. 580 (pag. 87)  
 Finiture come in foto | Finishes as in photo € 5.711,00  
 Tutta la composizione in lacc. opaco | Whole composition in matt lacq. finish € 5.513,00



**# COMP 110** L. 3360 H. 1960 P./D. 484 (pag. 93)  
 Finiture come in foto | Finishes as in photo € 3.899,00  
 Tutta la composizione in lacc. opaco | Whole composition in matt lacq. finish € 2.818,00



**# COMP 111** L. 3840 H. 1830 P./D. 484 (pag. 99)  
 Finiture come in foto | Finishes as in photo € 3.735,00  
 Tutta la composizione in lacc. opaco | Whole composition in matt lacq. finish € 3.622,00



## COMPOSIZIONI CATALOGO "SLIM UP" | "SLIM UP" CATALOGUE COMPOSITIONS

Il prezzo delle composizioni fotografiche Slim UP è calcolato utilizzando basi con frontali a ribalta e con braccetto normale a pistone, escluso di luci led ed accessori (braccetto a filo, luci led ed accessori optional a pag. 118).



**SLIM UP 01** L. 2560 H. 2175 P./D. 484 (pag. 4)  
 Finiture come in foto | Finishes as in photo € 3.614,00  
 Tutta la composizione in lacc. opaco | Whole composition in matt lacq. finish € 2.928,00



**SLIM UP 02** L. 3680 H. 2046 P./D. 484-580 (pag. 10)  
 Finiture come in foto | Finishes as in photo € 3.628,00  
 Tutta la composizione in lacc. opaco | Whole composition in matt lacq. finish € 3.196,00



**SLIM UP 03** L. 3846 H. 2035 P./D. 484 (pag. 16)  
 Finiture come in foto | Finishes as in photo € 4.385,00  
 Tutta la composizione in lacc. opaco | Whole composition in matt lacq. finish € 4.208,00



**SLIM UP 04** L. 2720 H. 1855 P./D. 484 (pag. 22)  
 Finiture come in foto | Finishes as in photo € 3.007,00  
 Tutta la composizione in lacc. opaco | Whole composition in matt lacq. finish € 2.447,00



**SLIM UP 05** L. 3040 H. 1795 P./D. 484 (pag. 28)  
 Finiture come in foto | Finishes as in photo € 4.074,00  
 Tutta la composizione in lacc. opaco | Whole composition in matt lacq. finish € 3.834,00



**SLIM UP 06** L. 2880 H. 1880 P./D. 484 (pag. 34)  
 Finiture come in foto | Finishes as in photo € 2.848,00  
 Tutta la composizione in lacc. opaco | Whole composition in matt lacq. finish € 2.617,00



**SLIM UP 07** L. 2560 H. 1700 P./D. 484 (pag. 40)  
 Finiture come in foto | Finishes as in photo € 3.950,00  
 Tutta la composizione in lacc. opaco | Whole composition in matt lacq. finish € 3.439,00



**SLIM UP 08** L. 4640 H. 2173 P./D. 484 (pag. 46)  
 Finiture come in foto | Finishes as in photo € 7.750,00  
 Tutta la composizione in lacc. opaco | Whole composition in matt lacq. finish € 6.842,00

## COMPOSIZIONI CATALOGO "SLIM UP" | "SLIM UP" CATALOGUE COMPOSITIONS

The price of Slim UP photo composition is calculated on bases with flap doors with standard piston hinges, led lights and accessories not included (wire hinges, led lights and optional accessories on page 118).



**SLIM UP 09** L. 3840 H. 2495 P./D. 484 (pag. 52)  
Finiture come in foto | Finishes as in photo **€ 4.320,00**  
Tutta la composizione in lacc. opaco | Whole composition in matt lacq. finish **€ 3.667,00**



**SLIM UP 10** L. 1600 H. 3580 P./D. 484 (pag. 58)  
Finiture come in foto | Finishes as in photo **€ 4.314,00**  
Tutta la composizione in lacc. opaco | Whole composition in matt lacq. finish **€ 3.809,00**

TIPOLOGIE DI SPALLE, DIVISIONI E PIANI | TYPES OF SIDE PANELS, PARTITIONS AND BENCHES

- 1) Spalla a terra sp. 30  
Free-standing structural side panel Th. 30
- 2) Spalla con scanco sp.30 per basi h.320 (a terra o pensile)  
Structural side panel Th. 30 with undercut for bases h. 320 (free-standing or wall unit)
- 3) Spalla sovrapposta a basi o a ripiani sp. 30 (sempre pensile)  
Structural side panel Th. 30 superimposed on bases or shelves (wall units only)
- 4) Spalla pensile sp. 30  
Wall unit structural side panels Th. 30
- 5) Divisione a terra sp. 30  
Free-standing partition Th. 30
- 6) Divisione a terra sp. 30 per piano sporgente  
Free-standing partition Th. 30 for protruding bench
- 7) Divisione tra ripiani sp. 30  
Partition between shelves Th. 30
- 8) Piano scrittoio sp. 50 - P. 580  
Desk top Th. 50 - D. 580
- 9) Piano sporgente sp. 50 - P. 484  
Protruding bench Th. 50 - D. 484

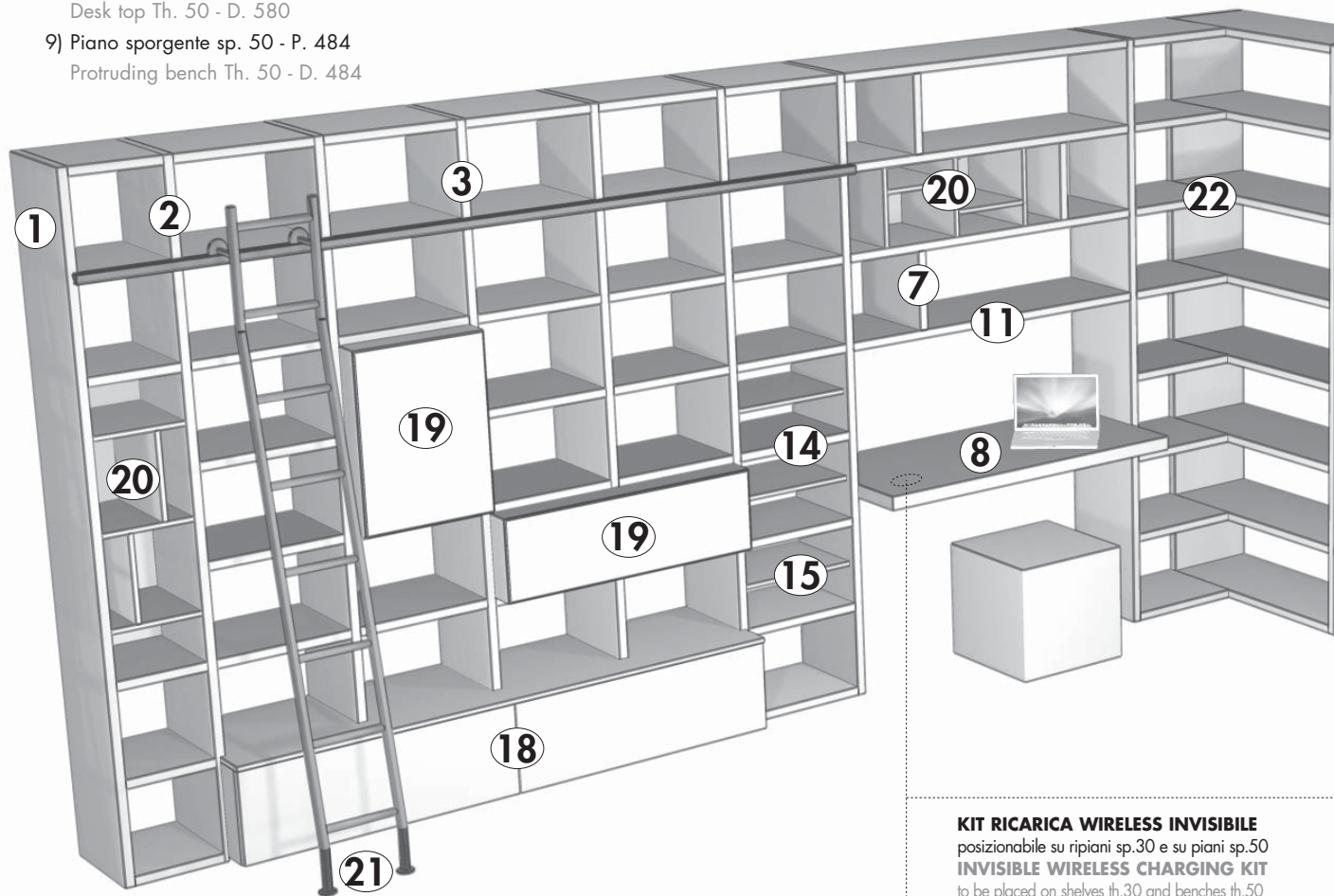

**KIT RICARICA WIRELESS INVISIBILE**  
 posizionabile su ripiani sp.30 e su piani sp.50  
**INVISIBLE WIRELESS CHARGING KIT**  
 to be placed on shelves th.30 and benches th.50



TIPOLOGIE DI RIPIANI ED ACCESSORI | TYPES OF SHELVES AND ACCESSORIES

- 10) Ripiano passante sp. 30 (supportato da spalle pensili)  
Feedthrough shelf Th. 30 (supported by wall unit side panels)
- 11) Ripiano passante sp. 30 (supportato da barra antiflessione)  
Feedthrough shelf Th. 30 (supported by an anti-flexure bar)
- 12) Ripiano passante sp. 30 (supportato da divisione a terra)  
Feedthrough shelf Th. 30 (supported by a free-standing partition)
- 13) Ripiano per mediacenter sp. 30  
Mediacenter shelf Th. 30
- 14) Ripiano su schiena sp. 30  
Shelf with back panel Th. 30
- 15) Ripiano su o senza schiena sp. 15  
Shelf with or without a back panel Th. 15
- 16) Mediacenter o schienale per TV  
Mediacenter or TV back panel
- 17) Elemento con 3 cassettini L. 449 H. 449  
Element with 3 drawers L. 449 H. 449
- 18) Base a terra "Slim"  
"Slim" free-standing base unit
- 19) Contenitori sporgenti P. 458  
Jutting storage units D. 458
- 20) Elementi a giorno  
Open elements
- 21) Sistema con scala scorrevole  
System with sliding ladder
- 22) Angolo a giorno  
Open corner

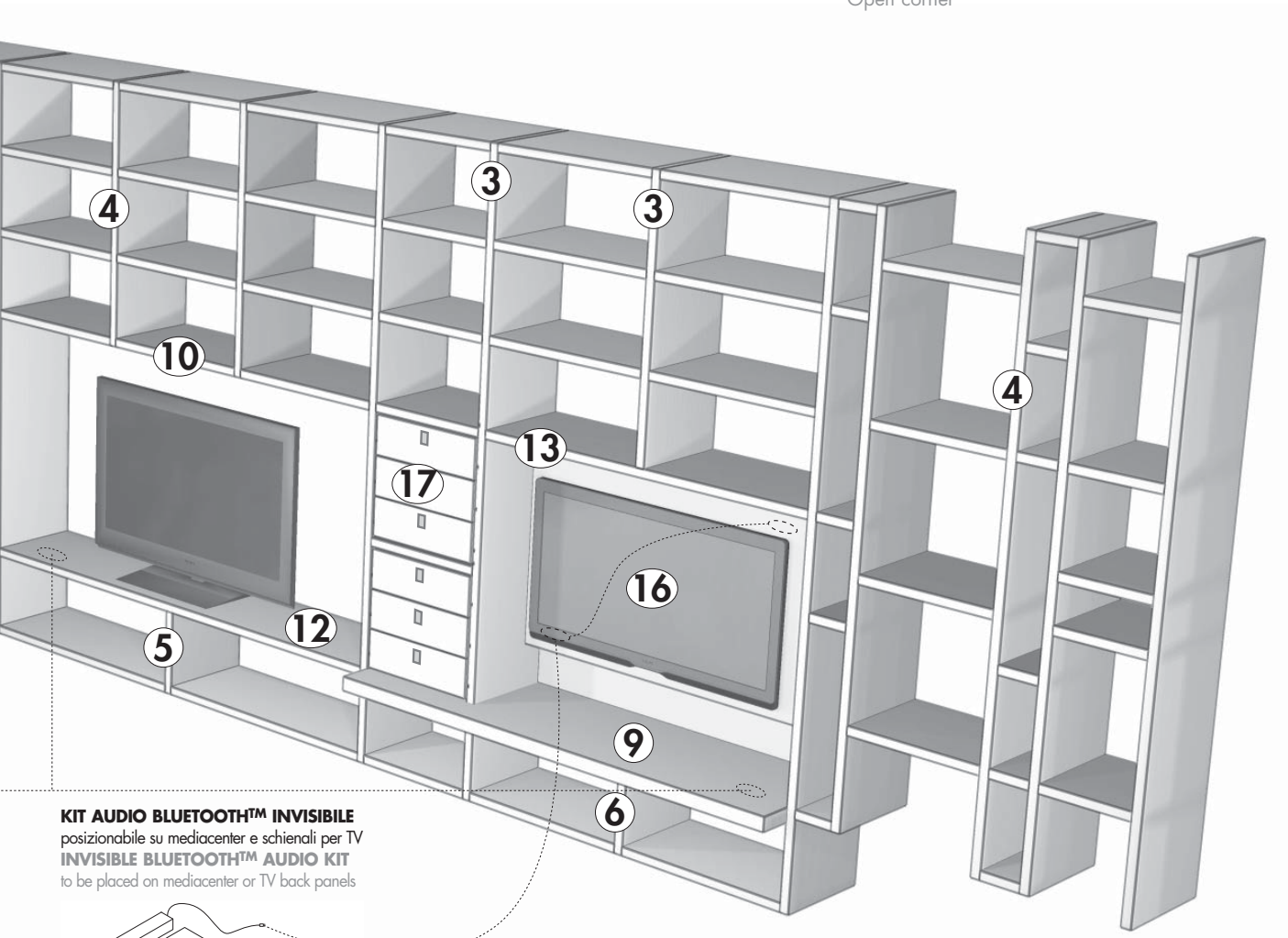

**KIT AUDIO BLUETOOTH™ INVISIBILE**  
 posizionabile su mediacenter e schienali per TV  
**INVISIBLE BLUETOOTH™ AUDIO KIT**  
 to be placed on mediacenter or TV back panels

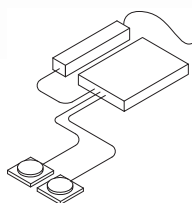



**MODULARITÀ ORIZZONTALE | HORIZONTAL MODULES**

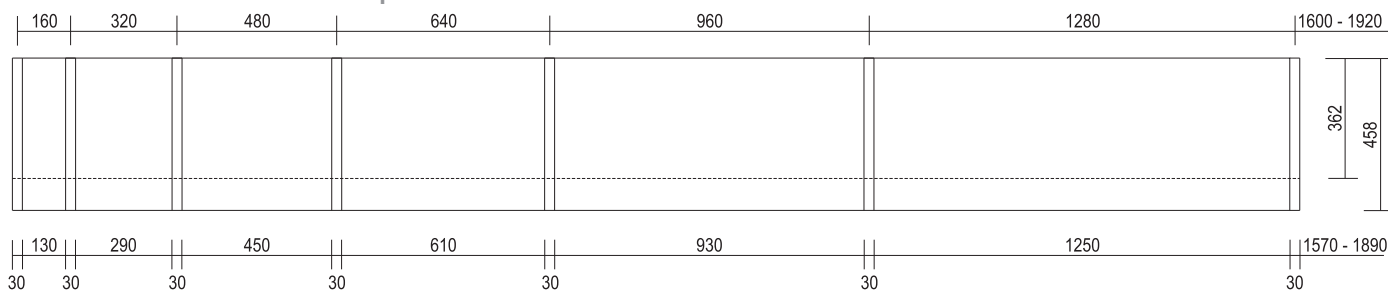

**MODULARITÀ VERTICALE | VERTICAL MODULES**

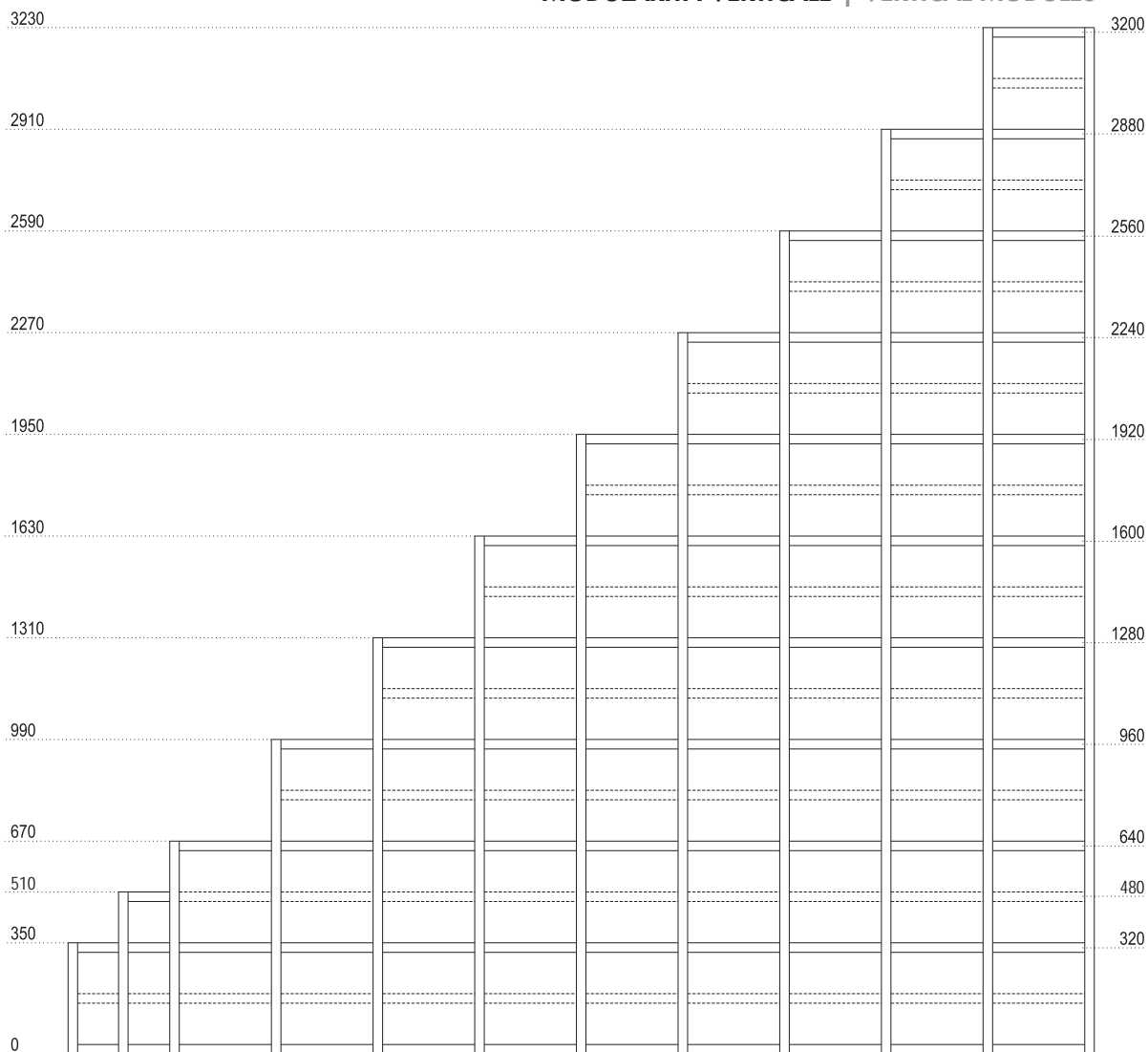

**PROFONDITÀ | DEPTH**

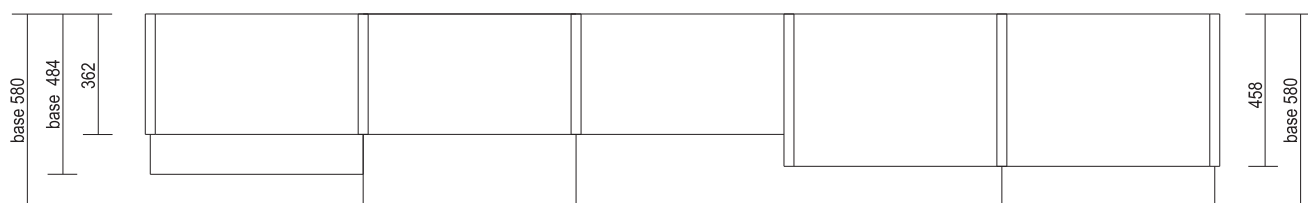

ALLINEAMENTI E CAMBIO DI PROFONDITÀ | ALIGNMENT AND CHANGE OF DEPTH

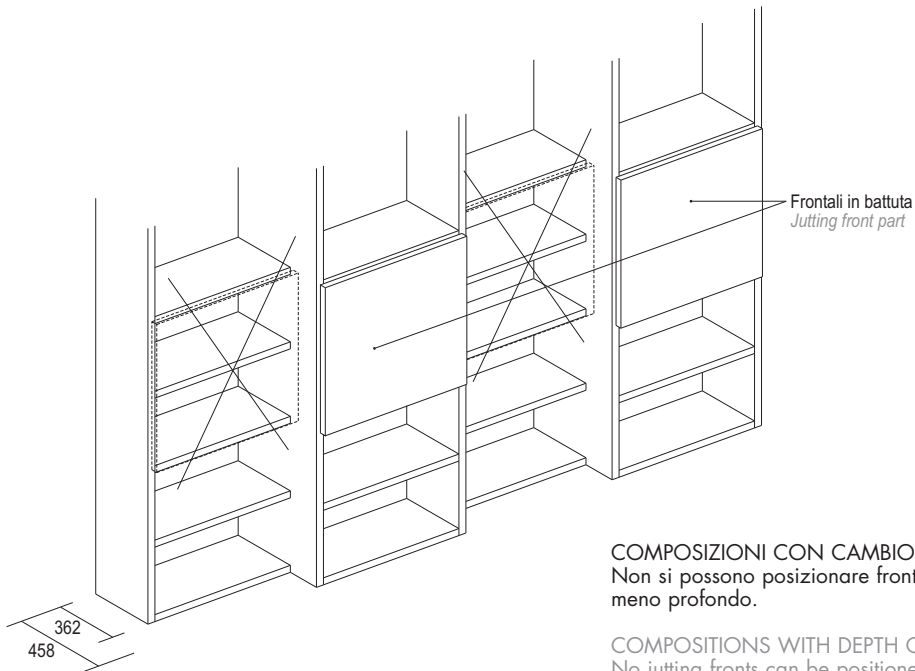
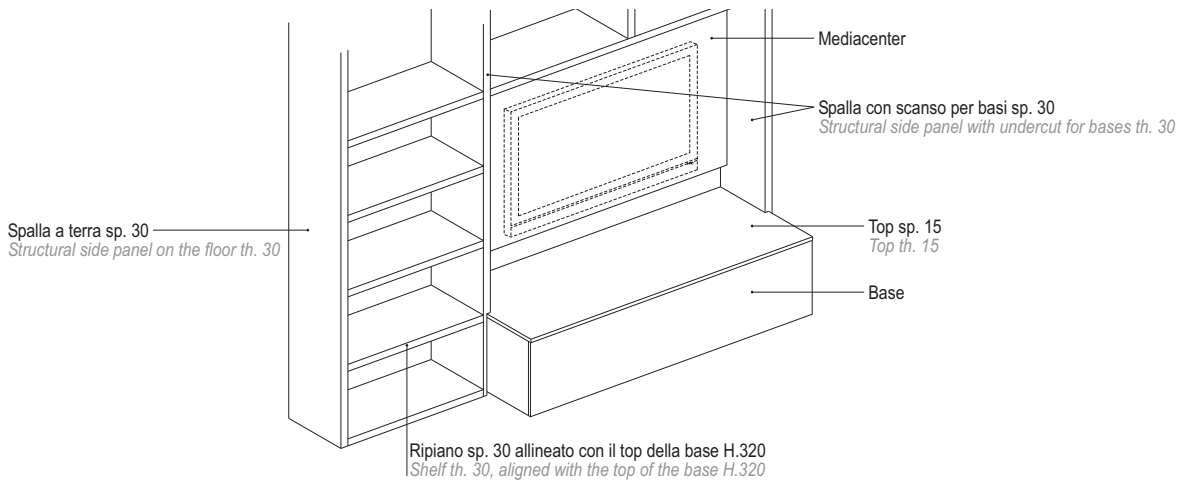

COMPOSIZIONI CON CAMBIO DI PROFONDITÀ:  
Non si possono posizionare frontali in battuta nel vano meno profondo.

COMPOSITIONS WITH DEPTH CHANGE:  
No jutting fronts can be positioned in the compartment with smaller depth.

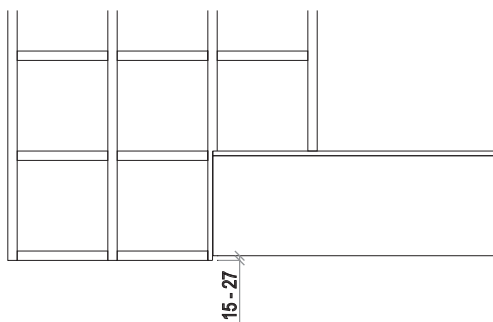

DISLIVELLO NELL'ABBINAMENTO SLIM / SPEED:  
Posizionando basi Slim accoppiate a spalle con scanso Speed si determina un dislivello nella parte inferiore che può variare da 15 a 27 mm in base al top impiegato nella base (legno, Laminam® o metallo).

GAP IN COMBINATION OF SLIM/SPEED:  
Placing Slim bases next to Speed shaped side panels, the result is a difference in height on the lower part of the composition. The gap might vary from 15 to 27 mm accordingly to the type of top used (wood, Laminam® or metal).

**DIMENSIONI MASSIME DELLE SCHIENE | MAXIMUM DIMENSIONS OF BACK PANELS**

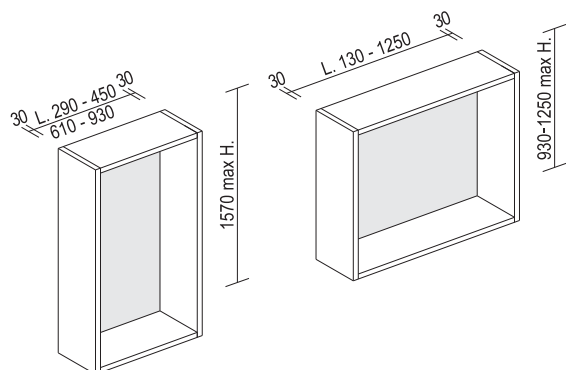

Per le larghezze 1250 l'altezza massima della schiena è di 930.  
 Per le larghezze 130 l'altezza massima della schiena è di 1250.  
 Per le altre larghezze l'altezza massima è 1570.  
 È necessario quindi suddividere in due il vano con una ripiano legno passante mettendo due schiene.  
 For widths 1250 the maximum height available for back panels is 930.  
 For widths 130 the maximum height available for back panels is 1250.  
 For all the other widths, the maximum height is 1570.  
 The compartment needs therefore to be divided into two parts by means of a feedthrough wooden shelf and two backs.

**ASSONOMETRIA E SEZIONE DI UNA COLONNA | AXONOMETRIC PROJECTION AND SECTION OF A COLUMN**

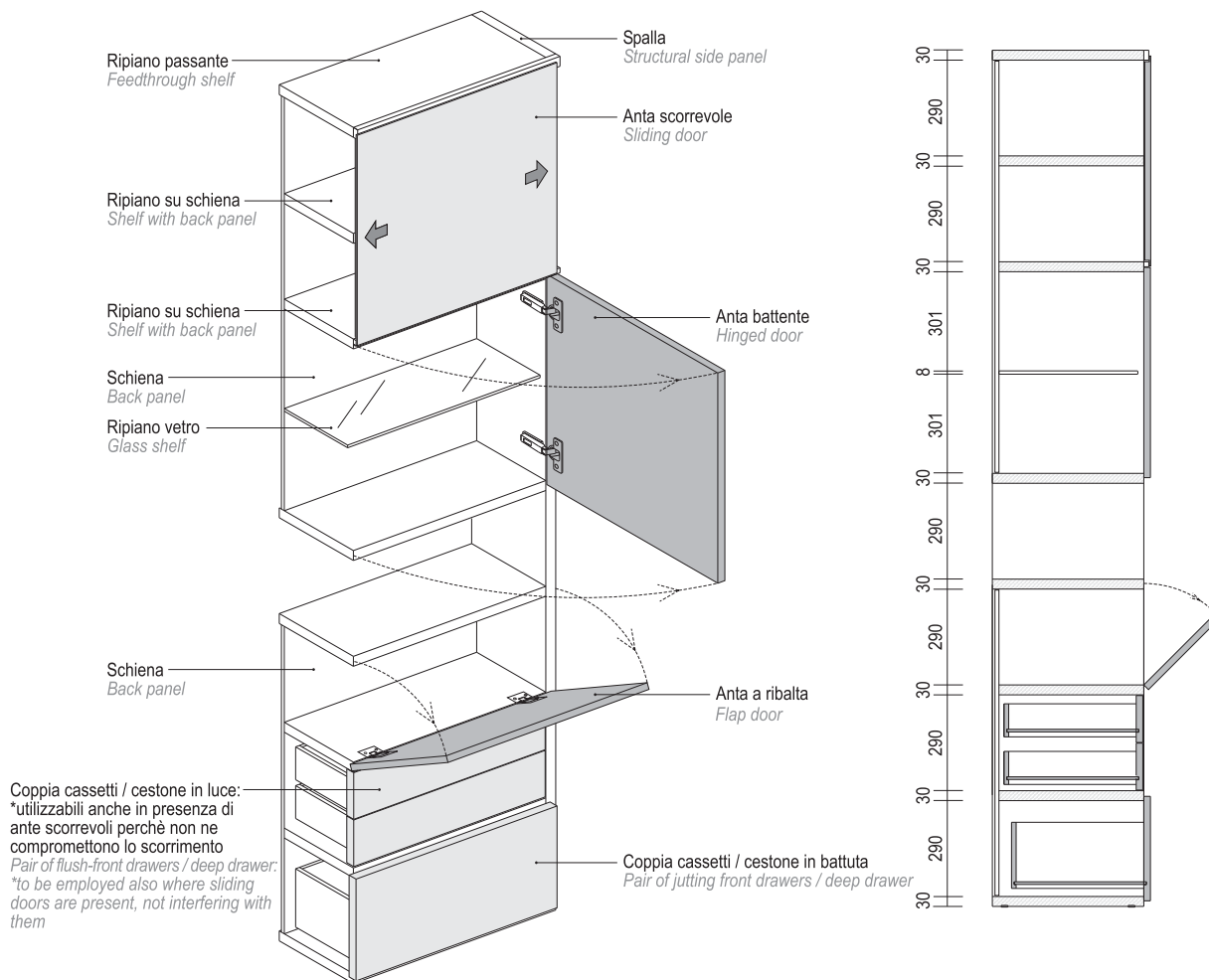

I cassetti / cestoni sono dotati di guide ad estrazione parziale; a richiesta disponibili con maggiorazione guide ad estrazione totale (vedi pag. 175).  
 The drawers / deep drawers are equipped with single extension pull-out runners; available on demand with a surcharge for full extension pull-out runners (see page 175).

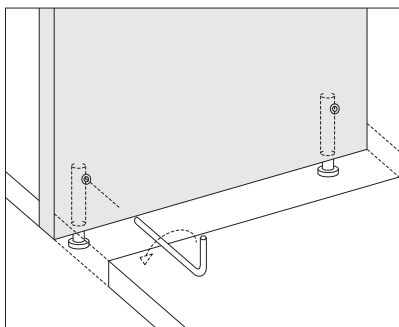

**SPALLE | STRUCTURAL SIDE PANELS**

Le spalle sono realizzate in pannelli di particelle di legno E1, impiallacciati essenza oppure laccati colorati opachi, lucidi, con superfici up o melaminico rovere termotrattato, spessore 30 mm in 2 profondità 362 - 458.

Si sconsiglia l'abbinamento tra melaminico rovere termotrattato ed essenza rovere termotrattato.

The structural side panels are made of 30 mm-thick E1 wood particleboard panels. They are either wood-veneered, matt-lacquered, gloss-lacquered, have UP surfaces or have a heat-treated oak melamine finish. They come in two depths: 362 and 458 mm. Matching melamine heat-treated oak and wood veneer heat-treated oak is not recommended.

**REGOLAZIONE IN ALTEZZA | HEIGHT ADJUSTMENT**

Le spalle in appoggio a terra sono dotate di piedini regolabili in altezza inseriti nello spessore.

Attraverso un foro laterale con apposita ghiera di copertura cromata è possibile mettere a livello la composizione mediante chiave a brugola. L'estensione di regolazione del piedino arriva ad un massimo di 18 mm.

The free-standing structural side panels are equipped with adjustable feet set in their thickness. The composition can be levelled with an Allen key, by adjusting the special chrome covering ring nut in a side hole. The foot can be adjusted to a maximum of 18 mm.

**FORATURA | DRILLING**

La realizzazione di ogni composizione SPEED avviene con personalizzazioni su ordine. La foratura sulla spalla verrà eseguita solo dove sono previsti ripiani, cassetti, ante e schiene.

Each SPEED composition is produced with customization on request. The drilling on the side panel will be carried out only where shelves, drawers, doors and backs are included.

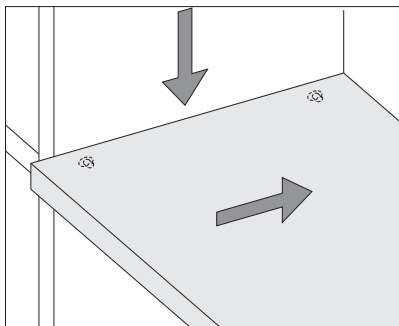

**RIPIANI | SHELVES**

I ripiani sono realizzati in pannelli di particelle di legno E1, impiallacciati essenza oppure laccati colorati opachi, lucidi, con superfici up o melaminico rovere termotrattato, spessore 30 mm.

Tutti i ripiani, a parte il ripiano strutturale uso fondo e ripiano per mediacenter, hanno l'inserimento e aggancio frontale invisibile, possono essere passati con la stessa profondità della spalla o in appoggio su schiena (20 mm più corti dal retro). Con il nuovo sistema di aggancio non sarà possibile realizzare la terza di fori per l'eventuale spostamento del ripiano.

The shelves are made of 30 mm-thick E1 wood particleboard panels. They are either wood-veneered, matt-lacquered, gloss-lacquered, have UP surfaces or have a heat-treated oak melamine finish.

All of the shelves, apart from the structural bottom shelf and the mediacenter shelf, have a concealed front insertion and fastening system. They can be feedthrough shelves with the same depth as the side panel, or supported on a back panel (20 mm shorter than the back).

With the new front mounting system for shelves with fully-concealed hardware, additional holes cannot be made for the shelf to be moved.

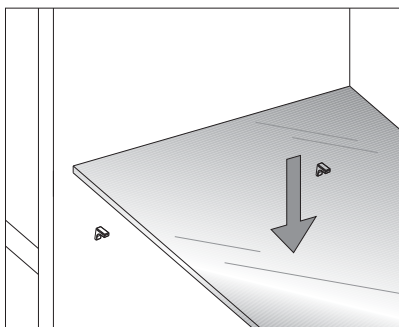

**RIPIANI VETRO | GLASS SHELVES**

I ripiani vetro hanno uno spessore di 8 mm, utilizzabili su vani con larghezze 290 - 450 - 610 - 930.

Sono dotati di reggipiani in acciaio con gommino trasparente per l'appoggio.

Per ante con modulo in altezza da 640 - 960 - 1280, il vano può essere con tutti ripiani vetro.

Per ante con modulo in altezza da 1600 - 1920 - 2240, il vano sarà suddiviso con ripiani vetro e ripiani legno sp.30, per dare struttura alla composizione e per utilizzare schiene con moduli fissi.

The glass shelves have a thickness of 8 mm, and they can be used on compartments with the following lengths L.290 - 450 - 610 - 930. They are equipped with steel shelf-holders with transparent rubber tips for support.

For doors used with a module of height 640 - 960 - 1280, the compartment can be completely provided with glass shelves.

For doors used with a module of height 1600 - 1920 - 2240, the compartment will be divided with glass and wooden shelves th.30 mm, in order to strengthen the body of the composition and use back panels with fixed modules.

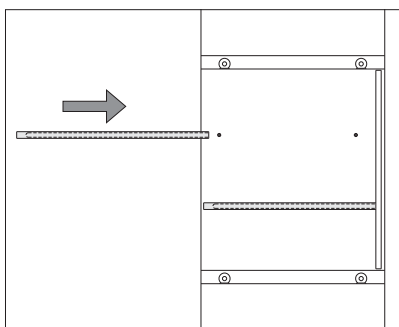

**RIPIANI SP.15 mm ED ELEMENTI A GIORNO | SHELVES TH. 15 mm AND OPEN ELEMENTS**

I ripiani e gli elementi a giorno sono realizzati in pannelli di particelle di legno E1, impiallacciati essenza oppure laccati colorati opachi, lucidi, con superfici up o melaminico rovere termotrattato, spessore 15 mm.

Il ripiano sp.15 di norma è in appoggio su schiena. Può essere richiesto anche senza schiena e in tal caso il ripiano avrà una posizione arretrata di 20 mm.

I ripiani sp.15 sono dotati di sistema di aggancio alla spalla ad innesto frontale.

The shelves and open elements are made from 15 mm-thick E1 wood particleboard panels. They are either wood-veneered, matt-lacquered, gloss-lacquered, have UP surfaces or have a heat-treated oak melamine finish.

The 15 mm-thick shelf is normally supported by the back panel.

It can also be requested without the back, and in this case the position of the shelf will be retracted by 20 mm.

The shelves are equipped with a front-coupling system in order to fasten them to the side panels.

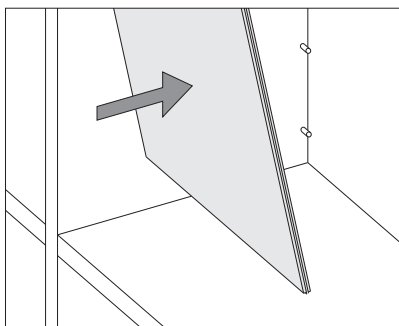

**SCHIENE | BACK PANELS**

Le schiene sono realizzate in pannelli di particelle di legno E1, impiallacciati essenza oppure laccati colorati opachi, lucidi, con superfici up o melaminico rovere termotrattato, spessore 12 mm.

Gli schienali sono completi di profilo antipolvere in gomma su 4 lati.

Il posizionamento avviene frontalmente, di facile innesto e lo schienale andrà in appoggio su fermaschiena metallici a scomparsa. Tale operazione avverrà a composizione montata.

The back panels are made from 12 mm-thick E1 wood particleboard panels. They are either wood-veneered, matt-lacquered, gloss-lacquered, have UP surfaces or have a heat-treated oak melamine finish.

The back pieces are provided with anti-dust rubber profiles on all 4 sides.

The positioning occurs frontally with easy coupling, and the back will lean against concealed metal backstops.

This operation shall take place once the composition has been assembled.



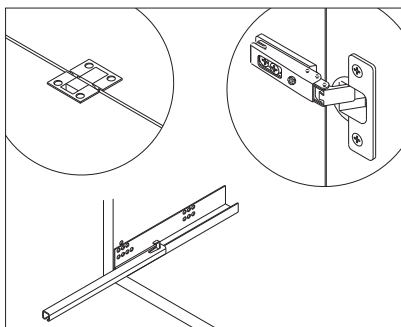

## SISTEMI DI APERTURA-CHIUSURA | OPENING AND CLOSING SYSTEMS

Nello SPEED sono previste 4 tipologie di apertura: Anta battente - Ribalta - Cassetti/Cestoni - Ante scorrevoli. Le ante battenti hanno due sistemi di apertura, push o maniglia. Le ante di serie sono previste con apertura push (con cricchetto a spinta). Le ante con maniglia sono dotate di cerniere con sistema di chiusura ammortizzato (soft). Le ribalte con apertura verso il basso hanno cerniere piate, mentre le ribalte con apertura verso l'alto utilizzano le stesse cerniere delle ante battenti; apertura di serie push o con maniglia. I braccetti utilizzati sulle ribalte verso il basso sono: braccetti a pistone con apertura push pull o maniglia; braccetti a filo esclusivamente con maniglia. I cassetti/cestoni in battuta di serie sono dotati di guide con apertura push e sincronizzatore che ne facilita l'apertura. I cassetti/cestoni con maniglia sono dotati di guide con sistema di chiusura ammortizzato (soft).

The SPEED system is available with 4 types of opening solutions: hinged doors, flap doors, drawers/deep drawers and sliding doors. Hinged doors are available with a push opening or a handle. Doors are fitted as standard with a push opening. Doors with a handle are fitted with shock-absorbing hinges (soft closure). Downward-opening flap doors are available with flat hinges, whilst the ones that open upwards are designed with the same hinges used for hinged doors (standard push opening or with a handle). The lid supports used on the downward-opening flap are: piston lid supports with a push and pull opening and a handle or wire hinges with a handle only. For the upwards-opening flap, only the piston lid support with a push and pull opening and a handle is available. Standard jutting drawers/deep drawers are supplied with push tracks and a synchronizing device which makes the opening easier. Drawers with handle are provided with dampened tracks (soft closure system).

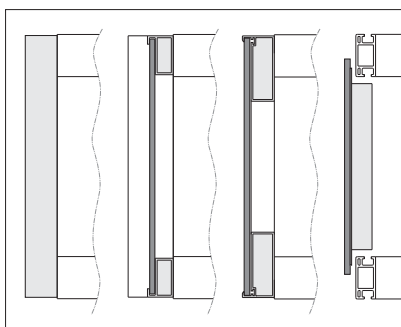

## FRONTALI LEGNO | WOODEN FRONTS

Ante battenti, a ribalta, frontali cassetti e cestoni sono realizzati in pannelli di particelle di legno E1 spessore 20 mm, impiallacciati essenza oppure laccati opachi, lucidi, con superfici up o melaminico rovere termotrattato. Sono di serie con apertura "push and pull" o a richiesta con maniglia. The hinged doors, flap doors and drawer and deep drawer fronts are made from 20 mm-thick E1 wood particleboard panels. They are either wood-veneered, matt-lacquered, gloss-lacquered, have UP surfaces or have a heat-treated oak melamine finish. They are fitted as standard with a "push and pull" opening or supplied with handles on request.

## ANTE TELAIO SLIM-SPEED | SLIM-SPEED FRAME DOORS

Sono composte da telai in alluminio finitura brown o bianco e da vetro sp. 4 mm. I vetri stopsol fumé e trasparenti lasciano intravedere il telaio sottostante. Le ante telaio sono battenti e a ribalta, disponibili solo con apertura "push and pull".

These doors consist of aluminium frames in a white or brown finish and 4 mm-thick glass. The underlying frame can be seen through the stopsol and transparent glass. Frame doors can be hinged or flap doors and are only available with a "push and pull" opening".

## ANTE TELAIO UP | UP FRAME DOORS

Sono composte da telai in alluminio finitura brown e da vetro trasparente grigio sp. 4 mm. Le ante telaio up sono solo battenti e disponibili con apertura tramite presa laterale sul telaio e chiusura ammortizzata. Sono utilizzabili esclusivamente su pensili senza l'impiego di top.

These doors consist aluminium frames in a white or brown finish and 4 mm-thick grey transparent glass. Only hinged doors are available for frame doors with a side handle opening and a soft close system. They can only be used for wall units with no tops.

## ANTE SCORREVOLI SPEED | SPEED SLIDING DOORS

Le ante scorrevoli sono composte da telaio in alluminio e da due tipologie di frontali, legno e vetro. Il telaio scorre su pattini regolabili in altezza. I frontali sono: in pannelli di particelle E1 impiallacciati essenza oppure laccati opachi, lucidi o con superfici up; in vetro sp.4 mm. I binari su cui scorrono le ante sono in alluminio applicabili direttamente alla struttura con viti autofilanti. Hanno una copertura (chiusura frontale) H.30 e H.15 in finitura alluminio o laccato opaco colori a cartella. The sliding doors are composed of an aluminium frame and two types of fronts: wood and glass. The frame slides on height-adjustable sliding blocks. The fronts are made from E1 wood particleboard panels. They are either wood-veneered, matt-lacquered, gloss-lacquered, have UP surfaces or have 4mm thick glass. The tracks on which the doors slide are aluminium and can be attached directly to the structure with self-locking screws. They have a 30 mm and 15 mm-high cover (front closure), available in an aluminium finish or a matte lacquer from our standard colour range.

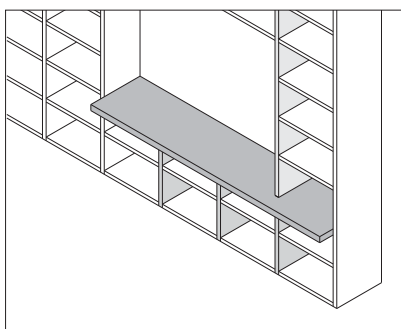

## PIANI, SCRIVANIE E HOME OFFICE SP. 50 | BENCHES, WRITING DESKS AND HOME OFFICE TH. 50

Sono realizzati in pannelli di particelle di legno E1 spessore 50 mm, impiallacciati essenza oppure laccati opachi, lucidi, con superfici up o melaminico rovere termotrattato.

Piano home office: da utilizzare sospeso tramite staffe oppure sostenuto da 1 o più gambe di supporto in metallo. Lo schienale è realizzato in pannelli di particelle di legno E1 spessore 25 mm, disponibile nelle stesse finiture del piano e a richiesta anche con luce led superiore.

La tenuta dei sistemi di fissaggio al muro è garantita dal corretto utilizzo dei tasselli, adeguati al tipo di parete (calcestruzzo, cartongesso, laterizio, ecc.), pertanto l'Azienda non fornisce alcun tipo di tassello e la responsabilità delle operazioni di montaggio è totalmente a carico del cliente.

They are made from 50 mm-thick E1 wood particleboard panels. They are either wood-veneered, matt-lacquered, gloss-lacquered, have UP surfaces or have a heat-treated oak melamine finish.

Home office desk: to be suspended or supported by 1 or more metal support legs. The back panel is made from 25 mm-thick E1 wood particleboard panels and is available in the same finishes as the bench. It can also be fitted with an upper LED light on request. The right wall-compatible screw plugs (concrete, plasterboard, brick, etc.) must be used to ensure that the mounting system is secured to the wall. Therefore, the company does not supply any screw plugs and the customer is solely responsible for the assembly.



## VERNICI | PAINTS

Le vernici utilizzate sono a basso residuo secco e atossiche. Per le essenze e i laccati opachi il ciclo di verniciatura è ad acqua, mentre per i laccati lucidi a solvente. Il tipo di finitura per l'essenza è a poro aperto e la superficie subisce una lavorazione di spazzolatura. Le vernici all'acqua hanno il marchio Europeo LIFE perché permettono di ridurre le emissioni di solventi in atmosfera, sono contraddistinte dall'assenza di odori e tutelano la salute dell'operatore e dell'utilizzatore finale. The paints employed are low-residue ones and atoxic. For the wood and lacquered finishes, water-borne paints are used. For the lacquered glossy finishes solvent-based paints are used. The wood finish is an open-pore one and the surface is submitted to a brushing process. Water-borne paints are identified by European LIFE trademark because they allow the reduction of the atmospheric emission of solvents and are characterized by the lack of scent, safeguarding the operator's and end consumer's health.

## SUPERFICI UP | UP SURFACE

Le finiture laccato effetto resina e laccato metallico sono realizzate con vernici a basso residuo secco e atossiche, il ciclo di verniciatura è ad acqua. L'applicazione della finitura effetto resina avviene tramite spruzzo e spatolatura manuale ottenendo un effetto cemento in tridimensionale. La finitura laccato metallico avviene tramite spruzzo e carteggiatura manuale ottenendo un effetto simile al metallo spazzolato. Essendo applicate manualmente si possono creare delle zone non uniformi, ma sicuramente di valore e di pregio, in quanto sono lavorazioni artigianali. Per la pulizia usare acqua detergente (50/50). The resin-effect lacquer finish is obtained using low dry residue and non-toxic paints, through a water-based painting cycle. The metal lacquer finish is created by manually spraying and sanding, in order to obtain a brushed metal-effect.

Since it is applied manually, there may be uneven areas, however this will only add to its value and prestige as these are handcrafted products. Use water and a cleaning agent to clean (50:50).

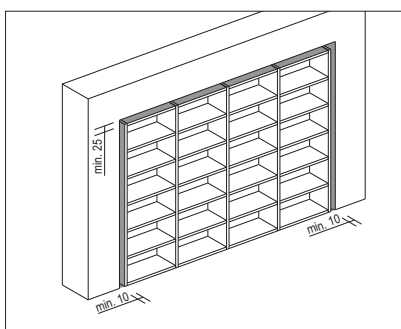

## SCALA | LADDER

La scala poggia a terra e scorre sul binario in alluminio; entrambi sono in finitura alluminio o brown.

L'altezza minima di una composizione a spalla per l'utilizzo di una scala è di 2270 mm.

Per sicurezza la composizione a spalla con scala deve essere sempre appoggiata a terra e fissata al muro.

The ladder rests on the ground and slides along the aluminium track, both in a white or brown finish.

The minimum height required for a side-panel composition in order to use a ladder is 2270 mm.

For safety reasons, the side panel composition with stepladder must always be supported on the ground and fixed to the wall.

## MONTAGGIO | ASSEMBLY

Per il montaggio del sistema spalla è necessario un ulteriore spazio minimo di 25 mm in altezza e 10 mm in larghezza, rispetto alle dimensioni totali della composizione. Per il calcolo della dimensione totale aggiungere 1 mm in più per ogni vano.

Attenzione: sommare alle misure date lo spessore dell'eventuale battiscopa.

The assembly of the side panel system requires an additional space of at least 25 mm in height and 10 mm in length with respect to the total dimensions of the composition. To calculate the total dimensions, add 1 mm more for every compartment.

Attention: Add the thickness of your skirting boards to the provided measurements.

N.B: Si sconsiglia l'abbinamento tra melaminico rovere termotrattato ed essenza rovere termotrattato | Matching melamine heat-treated oak and wood veneer heat-treated oak is not recommended.

- Sempre provviste di piedini di regolazione. - Always supplied with adjustable feet.	codice code	lacc. opaco matt lacq.	essenza cat. 1 wood cat. 1	essenza cat. 2 wood cat. 2	rovere lacc. matt lacq. oak	lacc. lucido glossy lacq.	materico rovere termo.
						superfici UP UP surface	heat-treat. oak textured f.

Spalle a terra  
Free-standing structural side panels

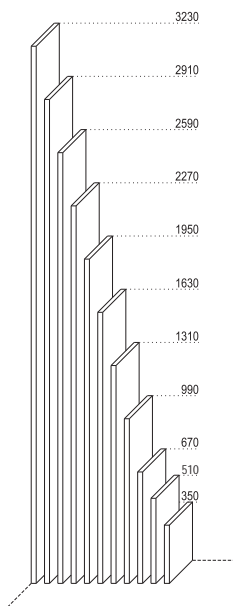

VOL.m³ Kg P. | D. 362

0,011	3	H. 350	SP1S3T33A	49	74	89	94	69	44
0,015	4	H. 510	SP1S3T33C	60	88	106	114	85	50
0,020	5	H. 670	SP1S3T33D	69	102	123	132	102	57
0,029	7,5	H. 990	SP1S3T33F	84	130	156	170	134	65
0,038	9,5	H. 1310	SP1S3T33I	101	157	188	207	158	74
0,047	11,5	H. 1630	SP1S3T33K	118	183	220	242	199	83
0,056	14	H. 1950	SP1S3T33M	133	209	251	278	232	92
0,065	16	H. 2270	SP1S3T33P	151	245	294	326	263	100
0,074	18,5	H. 2590	SP1S3T33R	168	273	328	363	297	108
0,083	20,5	H. 2910	SP1S3T33V	185	303	363	403	330	120
0,092	22,5	H. 3230	SP1S3T33X	204	330	396	440	361	132

VOL.m³ Kg P. | D. 458

0,014	3,5	H. 350	SP1S3T43A	54	83	100	106	78	49
0,019	5	H. 510	SP1S3T43C	66	99	119	129	100	57
0,025	6,5	H. 670	SP1S3T43D	76	116	140	152	120	63
0,036	9	H. 990	SP1S3T43F	97	146	175	193	159	76
0,047	12	H. 1310	SP1S3T43I	116	178	213	236	197	86
0,058	14,5	H. 1630	SP1S3T43K	133	212	255	285	236	93
0,069	17,5	H. 1950	SP1S3T43M	154	245	294	329	275	107
0,081	20	H. 2270	SP1S3T43P	174	286	343	383	316	116
0,092	23	H. 2590	SP1S3T43R	195	320	385	430	356	127
0,103	25,5	H. 2910	SP1S3T43V	214	354	425	476	398	140
0,114	28,5	H. 3230	SP1S3T43X	235	387	465	521	437	153

N.B: Si consiglia l'abbinamento tra melaminico rovere termotrattato ed essenza rovere termotrattato | Matching melamine heat-treated oak and wood veneer heat-treated oak is not recommended.

- Provviste di sistema di fissaggio a muro tramite attaccaglie regolabili in altezza e profondità. - Supplied with a wall mounting system that uses height and depth-adjustable brackets.	codice code	lacc. opaco matt lacq.	essenza cat. 1 wood cat. 1	essenza cat. 2 wood cat. 2	rovere lacc. matt lacq. oak	lacc. lucido glossy lacq.	materico rovere termo. heat-treat. oak
						superfici UP UP surface	heat-treat. oak textured f.

Spalle pensili  
Wall unit structural side panels

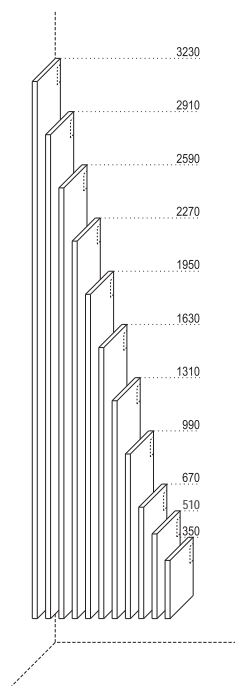

VOLm³	Kg	P.	D.						
<b>P.   D. 362</b>									
0,011	3	H. 350	SP1S3P33A	59	84	99	104	78	53
0,015	4	H. 510	SP1S3P33C	70	98	116	124	94	60
0,020	5	H. 670	SP1S3P33D	78	112	132	142	112	66
0,029	7,5	H. 990	SP1S3P33F	93	140	166	180	144	75
0,038	9,5	H. 1310	SP1S3P33I	111	167	198	216	168	84
0,047	11,5	H. 1630	SP1S3P33K	128	193	229	252	209	92
0,056	14	H. 1950	SP1S3P33M	143	219	261	288	241	102
0,065	16	H. 2270	SP1S3P33P	160	254	304	335	273	110
0,074	18,5	H. 2590	SP1S3P33R	178	282	337	373	307	118
0,083	20,5	H. 2910	SP1S3P33V	195	313	373	413	340	130
0,092	22,5	H. 3230	SP1S3P33X	213	340	405	450	371	142
<b>P.   D. 458</b>									
0,014	3,5	H. 350	SP1S3P43A	64	92	110	116	88	59
0,019	5	H. 510	SP1S3P43C	76	108	129	139	110	66
0,025	6,5	H. 670	SP1S3P43D	86	126	150	161	130	73
0,036	9	H. 990	SP1S3P43F	106	156	185	202	169	86
0,047	12	H. 1310	SP1S3P43I	126	187	223	246	207	96
0,058	14,5	H. 1630	SP1S3P43K	143	222	265	294	246	103
0,069	17,5	H. 1950	SP1S3P43M	164	254	304	339	285	117
0,081	20	H. 2270	SP1S3P43P	184	295	353	393	326	126
0,092	23	H. 2590	SP1S3P43R	205	330	395	440	366	137
0,103	25,5	H. 2910	SP1S3P43V	224	363	435	485	408	150
0,114	28,5	H. 3230	SP1S3P43X	245	397	475	531	447	162

# SPALLE SOVRAPPOSTE A BASI | STRUCTURAL SIDE PANELS SUPERIMPOSED ON BASES SP. | TH. 30

N.B: Si consiglia l'abbinamento tra melaminico rovere termotrattato ed essenza rovere termotrattato | Matching melamine heat-treated oak and wood veneer heat-treated oak is not recommended.

- Provviste di sistema di fissaggio a muro tramite attaccaglie regolabili in altezza e profondità.  
- Supplied with a wall mounting system that uses height and depth-adjustable brackets.

Spalle pensili sovrapposte a basi h. 160 - 480 o a ripiani  
Wall unit structural side panels superimposed on bases h. 160 - 480 or shelves

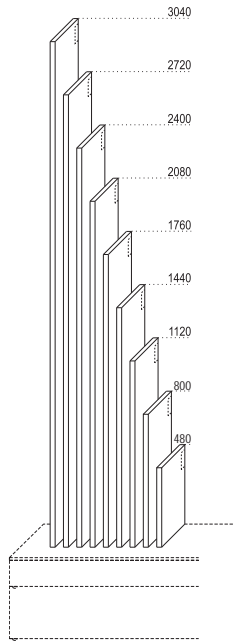

VOL.m<sup>3</sup> Kg **P. | D. 362**

codice code	lacc. opaco matt lacq.	essenza cat. 1 wood cat. 1	essenza cat. 2 wood cat. 2	rovere lacc. matt lacq. oak	lacc. lucido glossy lacq.	materico rovere termo. heat-treat. oak textured f.
H. 480 SP1S3S31B	52	87	104	112	78	48
H. 800 SP1S3S31E	65	108	130	142	107	56
H. 1120 SP1S3S31G	80	131	158	174	140	64
H. 1440 SP1S3S31J	99	161	194	214	175	73
H. 1760 SP1S3S31L	115	192	231	255	209	81
H. 2080 SP1S3S31O	133	226	272	301	245	92
H. 2400 SP1S3S31Q	148	260	312	345	277	99
H. 2720 SP1S3S31T	167	293	353	390	310	108
H. 3040 SP1S3S31W	184	328	394	436	343	120

VOL.m<sup>3</sup> Kg **P. | D. 458**

H. 480 SP1S3S41B	60	99	119	128	89	56
H. 800 SP1S3S41E	75	124	148	162	123	64
H. 1120 SP1S3S41G	91	154	185	205	170	73
H. 1440 SP1S3S41J	115	192	231	256	211	86
H. 1760 SP1S3S41L	135	227	273	304	252	97
H. 2080 SP1S3S41O	156	269	323	360	295	108
H. 2400 SP1S3S41Q	175	309	372	414	337	117
H. 2720 SP1S3S41T	196	348	418	466	380	128
H. 3040 SP1S3S41W	215	390	469	522	420	141

Spalle pensili sovrapposte a basi h. 320 o a ripiani  
Wall unit structural side panels superimposed on bases h. 320 or shelves

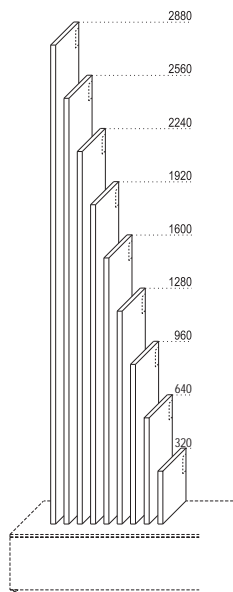

VOL.m<sup>3</sup> Kg **P. | D. 362**

H. 320 SP1S3S33A	44	75	90	96	61	42
H. 640 SP1S3S33D	59	98	117	127	94	52
H. 960 SP1S3S33F	74	119	143	157	128	65
H. 1280 SP1S3S33H	91	148	179	197	161	75
H. 1600 SP1S3S33K	108	177	212	235	196	84
H. 1920 SP1S3S33M	127	213	256	283	232	93
H. 2240 SP1S3S33P	144	248	297	329	267	104
H. 2560 SP1S3S33R	162	285	342	377	302	113
H. 2880 SP1S3S33U	182	318	382	422	339	124

VOL.m<sup>3</sup> Kg **P. | D. 458**

H. 320 SP1S3S43A	50	86	103	110	70	48
H. 640 SP1S3S43D	67	112	134	146	108	61
H. 960 SP1S3S43F	85	140	168	185	150	75
H. 1280 SP1S3S43H	105	175	211	234	194	87
H. 1600 SP1S3S43K	127	208	250	278	237	99
H. 1920 SP1S3S43M	147	252	303	336	279	108
H. 2240 SP1S3S43P	169	296	356	395	323	123
H. 2560 SP1S3S43R	191	339	407	452	366	133
H. 2880 SP1S3S43U	213	380	456	507	409	145

# SPALLE CON SCANSO | STRUCTURAL SIDE PANELS WITH UNDERCUT | BASI | BASES H. 160

N.B: Si consiglia l'abbinamento tra melaminico rovere termotrattato ed essenza rovere termotrattato | Matching melamine heat-treated oak and wood veneer heat-treated oak is not recommended.

- Posizionabili a terra oppure sospese con sistema di fissaggio a muro tramite attaccaglie regolabili in altezza e profondità.  
- Positionable as a free-standing unit or suspended with a wall mounting system with height and depth-adjustable brackets.

codice code	lacc. opaco matt lacq.	essenza cat. 1 wood cat. 1	essenza cat. 2 wood cat. 2	rovere lacc. matt lacq. oak	lacc. lucido glossy lacq.	materico rovere termo. heat-treat. oak textured f.
-------------	------------------------	----------------------------	----------------------------	-----------------------------	---------------------------	--

Spalle a terra con scanso per basi h. 160  
Free-standing structural side panels with an undercut for bases h. 160

VOLm³ Kg		P.   D. 362							
0,020	5	H. 670	SP1S3B31D	73	125	150	159	105	61
0,029	7,5	H. 990	SP1S3B31F	91	164	197	211	143	73
0,038	9,5	H. 1310	SP1S3B31I	115	199	239	258	181	92
0,047	11,5	H. 1630	SP1S3B31K	138	238	286	308	221	107
0,056	14	H. 1950	SP1S3B31M	160	295	355	382	264	123
0,065	16	H. 2270	SP1S3B31P	184	341	409	440	301	138
0,074	18,5	H. 2590	SP1S3B31R	207	381	457	493	340	154
0,083	20,5	H. 2910	SP1S3B31V	227	418	503	543	378	168
0,092	22,5	H. 3230	SP1S3B31X	249	457	549	593	417	184

VOLm³ Kg		P.   D. 458							
0,025	6,5	H. 670	SP1S3B41D	83	144	173	185	121	71
0,036	9	H. 990	SP1S3B41F	106	189	227	245	169	84
0,047	12	H. 1310	SP1S3B41I	130	235	282	305	214	106
0,058	14,5	H. 1630	SP1S3B41K	157	282	340	369	262	125
0,069	17,5	H. 1950	SP1S3B41M	184	340	408	442	310	144
0,081	20	H. 2270	SP1S3B41P	211	398	478	518	359	160
0,092	23	H. 2590	SP1S3B41R	236	443	532	577	403	181
0,103	25,5	H. 2910	SP1S3B41V	260	490	588	639	451	197
0,114	28,5	H. 3230	SP1S3B41X	286	539	647	704	497	216

Spalle pensili con scanso per basi h. 160  
Wall unit structural side panels with an undercut for bases h. 160

VOLm³ Kg		P.   D. 362							
0,020	5	H. 670	SP1S3G31D	83	134	159	169	115	71
0,029	7,5	H. 990	SP1S3G31F	101	173	207	221	153	83
0,038	9,5	H. 1310	SP1S3G31I	125	209	249	267	191	102
0,047	11,5	H. 1630	SP1S3G31K	147	248	295	318	231	117
0,056	14	H. 1950	SP1S3G31M	170	305	364	391	274	132
0,065	16	H. 2270	SP1S3G31P	194	350	418	450	310	147
0,074	18,5	H. 2590	SP1S3G31R	216	390	467	503	349	164
0,083	20,5	H. 2910	SP1S3G31V	237	428	512	552	388	178
0,092	22,5	H. 3230	SP1S3G31X	259	467	559	603	427	194

VOLm³ Kg		P.   D. 458							
0,025	6,5	H. 670	SP1S3G41D	92	154	183	195	131	80
0,036	9	H. 990	SP1S3G41F	116	199	237	254	179	93
0,047	12	H. 1310	SP1S3G41I	140	245	292	315	224	116
0,058	14,5	H. 1630	SP1S3G41K	167	292	349	378	272	134
0,069	17,5	H. 1950	SP1S3G41M	194	349	417	452	320	154
0,081	20	H. 2270	SP1S3G41P	221	408	488	528	369	170
0,092	23	H. 2590	SP1S3G41R	246	453	542	587	413	191
0,103	25,5	H. 2910	SP1S3G41V	269	499	598	648	461	207
0,114	28,5	H. 3230	SP1S3G41X	295	549	657	713	507	226

# SPALLE CON SCANSO | STRUCTURAL SIDE PANELS WITH UNDERCUT | BASI | BASES H. 320

N.B: Si sconsiglia l'abbinamento tra melaminico rovere termotrattato ed essenza rovere termotrattato | Matching melamine heat-treated oak and wood veneer heat-treated oak is not recommended.

- Posizionabili a terra oppure sospese con sistema di fissaggio a muro tramite attaccaglie regolabili in altezza e profondità.  
- Positionable as a free-standing unit or suspended with a wall mounting system with height and depth-adjustable brackets.

Spalle a terra con scanso per basi h. 320  
Free-standing structural side panels with an undercut for bases h. 320

VOL.m³		Kg		P.   D. 362						
0,020	4	H. 670	SP1S3B33D	70	121	146	156	100	67	
0,029	6,5	H. 990	SP1S3B33F	89	141	169	183	138	81	
0,038	8,5	H. 1310	SP1S3B33I	111	192	231	249	175	101	
0,047	10,5	H. 1630	SP1S3B33K	135	237	285	307	214	120	
0,056	13	H. 1950	SP1S3B33M	158	288	346	373	254	138	
0,065	16	H. 2270	SP1S3B33P	181	336	404	436	295	154	
0,074	17,5	H. 2590	SP1S3B33R	201	373	448	483	332	171	
0,083	19,5	H. 2910	SP1S3B33V	225	413	496	536	372	189	
0,092	21,5	H. 3230	SP1S3B33X	247	453	544	588	412	207	
VOL.m³		Kg		P.   D. 458						
0,025	5	H. 670	SP1S3B43D	79	138	166	178	115	78	
0,036	7,5	H. 990	SP1S3B43F	104	182	219	236	160	93	
0,047	10,5	H. 1310	SP1S3B43I	128	228	275	297	207	119	
0,058	13	H. 1630	SP1S3B43K	156	273	328	357	254	141	
0,069	16	H. 1950	SP1S3B43M	182	332	399	434	303	162	
0,081	18,5	H. 2270	SP1S3B43P	209	391	470	510	350	181	
0,092	21,5	H. 2590	SP1S3B43R	234	438	525	571	398	204	
0,103	24	H. 2910	SP1S3B43V	256	483	580	631	441	221	
0,114	27	H. 3230	SP1S3B43X	285	531	638	694	491	245	

Spalle pensili con scanso per basi h. 320  
Wall unit structural side panels with an undercut for bases h. 320

VOL.m³		Kg		P.   D. 362						
0,020	4	H. 670	SP1S3G33D	79	131	156	166	110	77	
0,029	6,5	H. 990	SP1S3G33F	99	151	179	193	147	91	
0,038	8,5	H. 1310	SP1S3G33I	120	201	240	259	185	111	
0,047	10,5	H. 1630	SP1S3G33K	145	247	294	317	224	130	
0,056	13	H. 1950	SP1S3G33M	168	297	356	383	264	147	
0,065	16	H. 2270	SP1S3G33P	191	346	414	445	305	164	
0,074	17,5	H. 2590	SP1S3G33R	211	383	457	493	342	181	
0,083	19,5	H. 2910	SP1S3G33V	235	423	506	546	382	199	
0,092	21,5	H. 3230	SP1S3G33X	256	463	553	598	422	216	
VOL.m³		Kg		P.   D. 458						
0,025	5	H. 670	SP1S3G43D	89	147	175	187	125	88	
0,036	7,5	H. 990	SP1S3G43F	114	192	228	246	170	103	
0,047	10,5	H. 1310	SP1S3G43I	138	238	285	307	216	129	
0,058	13	H. 1630	SP1S3G43K	166	282	337	367	264	151	
0,069	16	H. 1950	SP1S3G43M	192	342	409	443	313	172	
0,081	18,5	H. 2270	SP1S3G43P	219	401	480	520	360	191	
0,092	21,5	H. 2590	SP1S3G43R	243	448	535	580	408	213	
0,103	24	H. 2910	SP1S3G43V	266	493	590	641	451	231	
0,114	27	H. 3230	SP1S3G43X	294	540	647	704	501	199	



# SPALLE CON SCANSO | STRUCTURAL SIDE PANELS WITH UNDERCUT | BASI | BASES H. 480

N.B: Si consiglia l'abbinamento tra melaminico rovere termotrattato ed essenza rovere termotrattato | Matching melamine heat-treated oak and wood veneer heat-treated oak is not recommended.

- Posizionabili a terra oppure sospese con sistema di fissaggio a muro tramite attaccaglie regolabili in altezza e profondità.  
 - Positionable as a free-standing unit or suspended with a wall mounting system with height and depth-adjustable brackets.

codice code	lacc. opaco matt lacq.	essenza cat. 1 wood cat. 1	essenza cat. 2 wood cat. 2	rovere lacc. matt lacq. oak	lacc. lucido glossy lacq.	materico rovere termo. heat-treat. oak textured f.
					superfici UP UP surface	

Spalle a terra con scanso per basi h. 480  
 Free-standing structural side panels with undercut for bases h. 480

VOL.m³ Kg		P.   D. 362	
0,029	6,5	H. 990	SP1S3B34F
0,038	8,5	H. 1310	SP1S3B34I
0,047	10,5	H. 1630	SP1S3B34K
0,056	13	H. 1950	SP1S3B34M
0,065	16	H. 2270	SP1S3B34P
0,074	17,5	H. 2590	SP1S3B34R
0,083	19,5	H. 2910	SP1S3B34V
0,092	21,5	H. 3230	SP1S3B34X
VOL.m³ Kg		P.   D. 458	
0,036	7,5	H. 990	SP1S3B44F
0,047	10,5	H. 1310	SP1S3B44I
0,058	13	H. 1630	SP1S3B44K
0,069	16	H. 1950	SP1S3B44M
0,081	18,5	H. 2270	SP1S3B44P
0,092	21,5	H. 2590	SP1S3B44R
0,103	24	H. 2910	SP1S3B44V
0,114	27	H. 3230	SP1S3B44X

Spalle pensili con scanso per basi h. 480  
 Wall unit structural side panels with undercut for bases h. 480

VOL.m³ Kg		P.   D. 362	
0,029	6,5	H. 990	SP1S3G34F
0,038	8,5	H. 1310	SP1S3G34I
0,047	10,5	H. 1630	SP1S3G34K
0,056	13	H. 1950	SP1S3G34M
0,065	16	H. 2270	SP1S3G34P
0,074	17,5	H. 2590	SP1S3G34R
0,083	19,5	H. 2910	SP1S3G34V
0,092	21,5	H. 3230	SP1S3G34X
VOL.m³ Kg		P.   D. 458	
0,036	7,5	H. 990	SP1S3G44F
0,047	10,5	H. 1310	SP1S3G44I
0,058	13	H. 1630	SP1S3G44K
0,069	16	H. 1950	SP1S3G44M
0,081	18,5	H. 2270	SP1S3G44P
0,092	21,5	H. 2590	SP1S3G44R
0,103	24	H. 2910	SP1S3G44V
0,114	27	H. 3230	SP1S3G44X

N.B: Si sconsiglia l'abbinamento tra melaminico rovere termotrattato ed essenza rovere termotrattato | Matching melamine heat-treated oak and wood veneer heat-treated oak is not recommended.

		codice code	lacc. opaco matt lacq.	essenza cat. 1 wood cat. 1	essenza cat. 2 wood cat. 2	rovere lacc. matt lacq. oak	lacc. lucido glossy lacq.	materico rovere termo. heat-treat. oak textured f.
							superfici UP UP surface	
Divisioni tra ripiani Partitions between shelves								
	VOL.m³ Kg	<b>P.   D. 362</b>						
	0,009 2,5	H. 290 SP1D30331	46	67	81	86	61	37
	0,014 3,5	H. 450 SP1D30332	52	81	98	104	76	42
	0,018 4,5	H. 610 SP1D30333	60	96	115	124	92	45
	0,023 6	H. 770 SP1D30334	70	107	129	140	108	49
	0,027 7	H. 930 SP1D30335	79	124	148	161	129	53
	VOL.m³ Kg	<b>P.   D. 458</b>						
	0,012 3	H. 290 SP1D30431	48	73	88	93	67	42
	0,017 4,5	H. 450 SP1D30432	58	89	107	116	87	46
	0,023 6	H. 610 SP1D30433	67	105	127	138	107	50
	0,028 7,5	H. 770 SP1D30434	78	123	147	161	129	56
	0,034 8,5	H. 930 SP1D30435	89	142	171	187	152	61

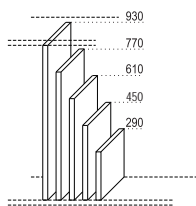

USO DEI RIPIANI: SEZIONE LATERALE | USE OF THE SHELVES: SIDE SECTION

! Con il nuovo sistema di aggancio frontale dei ripiani con ferramenta completamente a scomparsa, **NON SARÀ POSSIBILE REALIZZARE LA TERZINA DI FORI** per l'eventuale spostamento del ripiano.  
 With the new front mounting system for shelves with fully-concealed hardware, **ADDITIONAL HOLES CANNOT BE MADE** for the shelf to be moved.

N.B: Tutti i ripiani, a parte il ripiano strutturale uso fondo e ripiano per mediacenter, hanno l'inserimento e aggancio frontale.  
 N.B: All the shelves, except for the structural shelf or mediacenter shelf to be used as bottom panel, are inserted and fixed from the front.

**PENSILE**  
WALL UNIT

**A TERRA**  
FREE-STANDING

Ripiano passante (inserimento e aggancio laterale)  
Feedthrough shelf (inserted and fixed from the side)

Ripiano passante (inserimento e aggancio laterale)  
Feedthrough shelf (inserted and fixed from the side)



## USO DEI RIPIANI | USE OF THE SHELVES

N.B: Si consiglia l'abbinamento tra melaminico rovere termotrattato ed essenza rovere termotrattato | Matching melamine heat-treated oak and wood veneer heat-treated oak is not recommended.

I ripiani di lunghezza superiore a 930 devono essere necessariamente intervallati da divisioni tra ripiani, divisioni a terra oppure devono essere supportati da mediacenter o schiena per TV sp. 20 mm.

Per vani L. 930 - 1250 sono disponibili dei ripiani rinforzati che permettono di aumentare il carico di peso sul ripiano.

Shelves longer than 930 mm must be interspersed with partitions between the shelves or free-standing partitions, otherwise they must be supported by a 20 mm-thick media centre or TV back panel.

For 930-1250 mm-long compartments, reinforced shelves are available which can support a higher weight load.

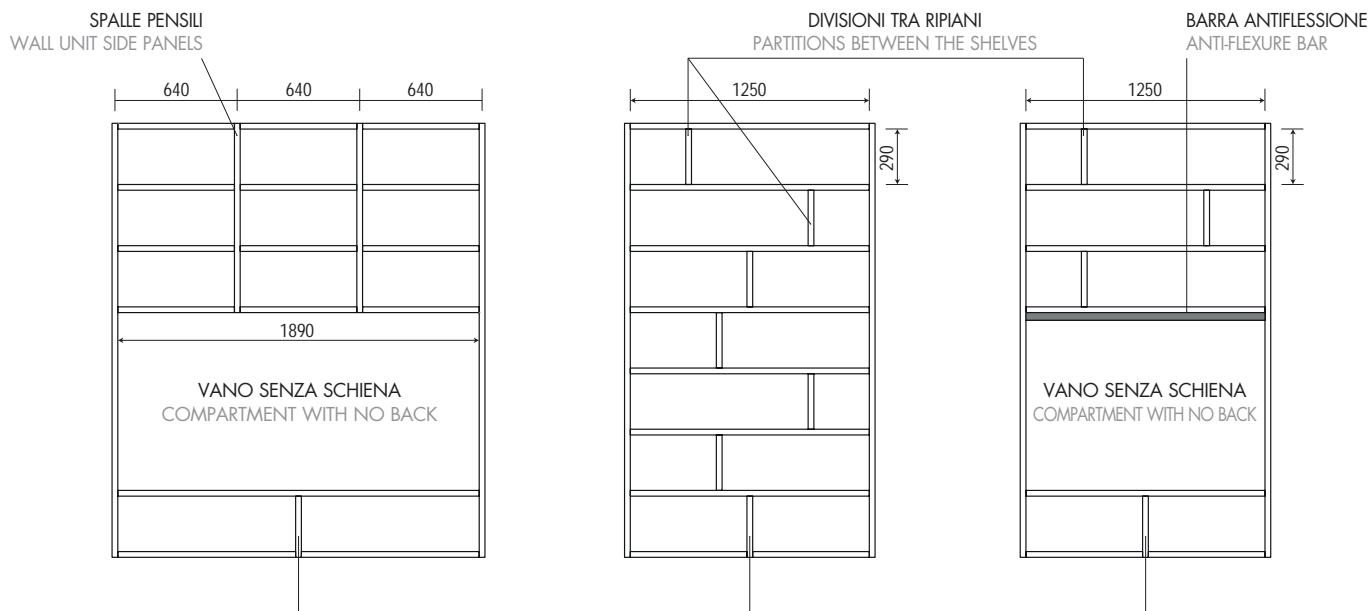

I ripiani di lunghezza superiore a 930 devono essere supportati dalla DIVISIONE A TERRA  
Shelves longer than 930 mm must be supported by a FREE-STANDING PARTITION

I ripiani rinforzati permettono di aumentare il carico di peso sul ripiano.  
Reinforced shelves are available which can support a higher weight load.

Ripiani passanti rinforzati Sp. 30  
Reinforced feedthrough shelves Th. 30

VOLm<sup>3</sup> Kg P. | D. 362

0,027 9,5

0,036 12

L. 930 SP1C32363

L. 1250 SP1C32373

150

215

259

272

195

134

VOLm<sup>3</sup> Kg P. | D. 458

0,034 10,7

0,045 14,5

L. 930 SP1C32463

L. 1250 SP1C32473

165

240

289

305

218

143

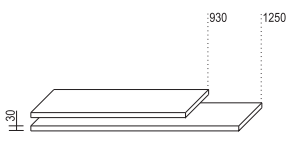

Ripiani su schiena rinforzati Sp. 30  
Reinforced shelves with back panel Th. 30

VOLm<sup>3</sup> Kg P. | D. 342

0,027 9,5

0,036 12

L. 930 SP1R32363

L. 1250 SP1R32373

148

213

256

269

191

133

VOLm<sup>3</sup> Kg P. | D. 438

0,034 10,7

0,045 14,5

L. 930 SP1R32463

L. 1250 SP1R32473

162

236

283

300

213

141

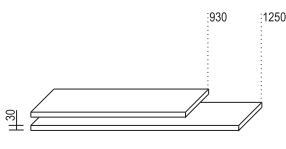

Barra antiflessione  
Anti-flexure bar

VOLm<sup>3</sup> Kg

0,0025 3,5

L. 1250

SP1X12211

31

47

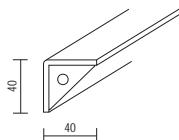

N.B: Si sconsiglia l'abbinamento tra melaminico rovere termotrattato ed essenza rovere termotrattato | Matching melamine heat-treated oak and wood veneer heat-treated oak is not recommended.

\* I ripiani di lunghezza superiore a 930 devono essere necessariamente intervallati da divisioni o supportati da mediacenter / schiena per TV. Sono disponibili anche ripiani rinforzati L. 930 - 1250.  
 \* Shelves longer than 930 mm, must be interspersed with partitions or supported by a media centre/TV back panel. 930-1250 mm-long reinforced shelves are also available.

Ripiani passanti Sp. 30  
 Feedthrough shelves Th. 30

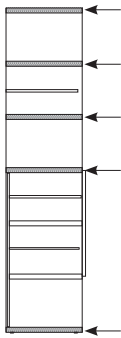

VOLm³ Kg P. | D. 362

codice code	lacc. opaco matt lacq.	essenza cat. 1 wood cat. 1	essenza cat. 2 wood cat. 2	rovere lacc. matt lacq. oak	lacc. lucido glossy lacq.	materico rovere termo. heat-treat. oak textured f.
L. 130 SP1C30313	30	43	51	53	37	25
L. 290 SP1C30323	36	54	65	70	52	30
L. 450 SP1C30343	46	70	84	90	69	33
L. 610 SP1C30353	54	83	100	108	84	37
L. 930 SP1C30363	73	108	130	143	116	46
L. 1250 SP1C30373	89	138	166	183	146	54
L. 1570 SP1C30383	108	166	199	221	179	63
L. 1890 SP1C30393	126	196	236	262	212	74

VOLm³ Kg P. | D. 458

L. 130 SP1C30413	33	48	58	61	43	29
L. 290 SP1C30423	39	61	74	79	59	33
L. 450 SP1C30443	50	78	94	103	81	36
L. 610 SP1C30453	60	92	111	121	99	42
L. 930 SP1C30463	85	128	154	170	137	53
L. 1250 SP1C30473	103	162	195	218	177	63
L. 1570 SP1C30483	125	196	236	264	214	73
L. 1890 SP1C30493	146	233	279	313	255	87

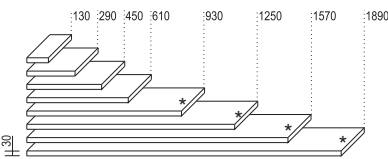

Ripiani su schiena Sp. 30  
 Shelves Th. 30 with a back panel

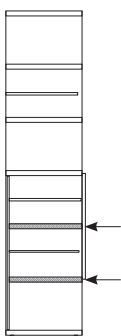

VOLm³ Kg P. | D. 342

L. 130 SP1R30313	29	42	50	52	36	24
L. 290 SP1R30323	35	56	67	72	49	29
L. 450 SP1R30343	44	67	81	88	64	32
L. 610 SP1R30353	51	79	96	104	80	35
L. 930 SP1R30363	72	107	129	142	110	45
L. 1250 SP1R30373	86	133	160	177	140	53

VOLm³ Kg P. | D. 438

L. 130 SP1R30413	32	46	56	58	42	27
L. 290 SP1R30423	38	60	72	77	58	32
L. 450 SP1R30443	49	75	90	98	78	35
L. 610 SP1R30453	59	91	110	120	94	40
L. 930 SP1R30463	83	123	147	164	131	52
L. 1250 SP1R30473	100	158	191	212	170	62

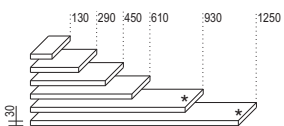

# RIPIANI | SHELVES

N.B: Si sconsiglia l'abbinamento tra melaminico rovere termotrattato ed essenza rovere termotrattato Matching melamine heat-treated oak and wood veneer heat-treated oak is not recommended.

- Nel caso questi ripiani vengano posizionati senza schiena sono arretrati di 20 mm rispetto al fronte  
- If these shelves are used without the back, their position is regressed of 20 mm in comparison with the front

Ripiani su o senza schiena Sp. 15  
Shelves Th. 15 with or without a back panel

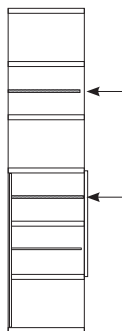

VOLm³ Kg P. | D. 336

code	lacc. opaco matt lacq.	essenza cat. 1 wood cat. 1	essenza cat. 2 wood cat. 2	rovere lacc. matt lacq. oak	lacc. lucido glossy lacq.	materico rovere termo. heat-treat. oak UP surface textured f.	
L. 130	SP1R15311	31	47	57	59	36	26
L. 290	SP1R15321	34	60	72	76	47	29
L. 450	SP1R15341	40	71	85	91	61	30
L. 610	SP1R15361	46	81	98	106	76	32

VOLm³ Kg P. | D. 432

L. 130	SP1R15411	32	52	63	65	40	29
L. 290	SP1R15421	37	64	77	83	54	32
L. 450	SP1R15441	45	77	93	101	72	33
L. 610	SP1R15461	52	92	111	121	89	37



Ripiani vetro trasparente Sp. 8  
Transparent glass shelves Th. 8

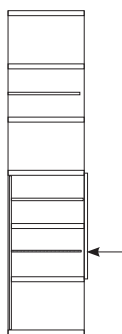

VOLm³ Kg P. | D. 320

code	lacc. opaco matt lacq.	essenza cat. 1 wood cat. 1	essenza cat. 2 wood cat. 2	rovere lacc. matt lacq. oak	lacc. lucido glossy lacq.	materico rovere termo. heat-treat. oak UP surface textured f.
L. 290	SP1VS8321	12				
L. 450	SP1VS8341	16				
L. 610	SP1VS8361	19				
L. 930	SP1VS8391	26				

VOLm³ Kg P. | D. 420

L. 290	SP1VS8421	15				
L. 450	SP1VS8441	19				
L. 610	SP1VS8461	22				
L. 930	SP1VS8491	31				

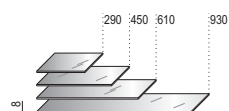

N.B: Si sconsiglia l'abbinamento tra melaminico rovere termotrattato ed essenza rovere termotrattato | Matching melamine heat-treated oak and wood veneer heat-treated oak is not recommended.

- Aggiungere solo se necessario il top | Add the top only if necessary  
 - Attenzione: non utilizzare il top con ante vetro UP perchè queste ante più profonde sporgerebbero di 15 mm  
 - Please note: Do not use the top with UP glass doors because these deeper doors will protrude out 15 mm.

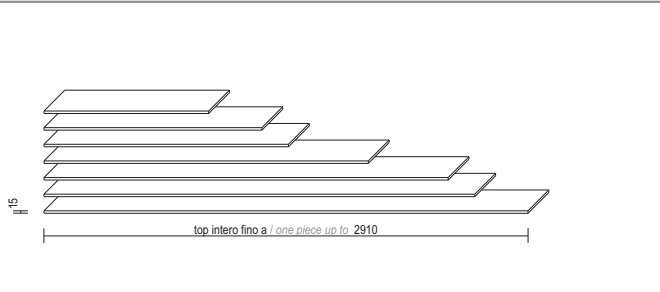

		<b>codice</b> code	<b>lacc. opaco</b> matt lacq.	<b>essenza cat. 1</b> wood cat. 1	<b>essenza cat. 2</b> wood cat. 2	<b>rovere lacc.</b> matt lacq. oak	<b>lacc. lucido</b> glossy lacq.	<b>materico</b> rovere termo. heat-treat. oak textured f.
VOLm³ Kg P.   D. 388								
0,024	4	L. 990 SP1T01310	<b>63</b>	<b>96</b>	<b>111</b>	<b>118</b>	<b>102</b>	<b>47</b>
0,032	5	L. 1310 SP1T01320	<b>79</b>	<b>117</b>	<b>135</b>	<b>145</b>	<b>129</b>	<b>58</b>
0,036	6	L. 1470 SP1T01330	<b>85</b>	<b>129</b>	<b>148</b>	<b>159</b>	<b>141</b>	<b>62</b>
0,047	8	L. 1950 SP1T01350	<b>111</b>	<b>171</b>	<b>197</b>	<b>212</b>	<b>182</b>	<b>76</b>
0,058	9,5	L. 2430 SP1T01360	<b>138</b>	<b>208</b>	<b>239</b>	<b>258</b>	<b>226</b>	<b>89</b>
0,062	10,5	L. 2590 SP1T01370	<b>144</b>	<b>215</b>	<b>248</b>	<b>267</b>	<b>238</b>	<b>93</b>
0,070	11,5	L. 2910 SP1T01380	<b>162</b>	<b>242</b>	<b>279</b>	<b>301</b>	<b>267</b>	<b>104</b>
VOLm³ Kg P.   D. 484								
0,030	5	L. 990 SP1T01410	<b>72</b>	<b>112</b>	<b>129</b>	<b>139</b>	<b>120</b>	<b>53</b>
0,039	6,5	L. 1310 SP1T01420	<b>90</b>	<b>140</b>	<b>161</b>	<b>174</b>	<b>151</b>	<b>66</b>
0,044	7,5	L. 1470 SP1T01430	<b>99</b>	<b>152</b>	<b>174</b>	<b>188</b>	<b>167</b>	<b>73</b>
0,058	10	L. 1950 SP1T01450	<b>129</b>	<b>200</b>	<b>231</b>	<b>249</b>	<b>214</b>	<b>89</b>
0,071	12	L. 2430 SP1T01460	<b>158</b>	<b>243</b>	<b>280</b>	<b>303</b>	<b>266</b>	<b>103</b>
0,076	13	L. 2590 SP1T01470	<b>167</b>	<b>256</b>	<b>295</b>	<b>319</b>	<b>282</b>	<b>108</b>
0,085	14,5	L. 2910 SP1T01480	<b>187</b>	<b>287</b>	<b>330</b>	<b>357</b>	<b>317</b>	<b>120</b>

COMPONIBILITÀ ORIZZONTALE | HORIZONTAL MODULARITY

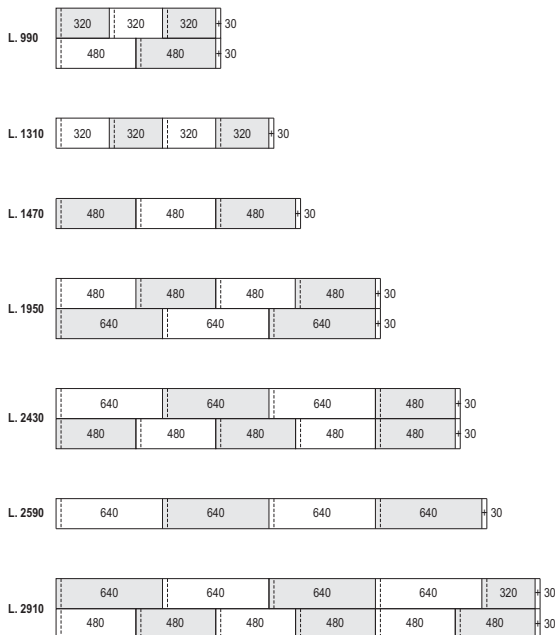

- Esempi di alcune tra le molteplici soluzioni di componibilità ottenibili con la combinazione dei vani disponibili nella gamma.
- La misura del top si ottiene sommando il modulo (già comprensivo della spalla sx) e il 30 della spalla dx finale.
- Examples of some of the multiple compositions which can be obtained by combining the various compartments available in the product range.
- The size of the top is obtained by summing the module (already including the lh side panel) and 30 of the final rh side panel.

N.B: Si sconsiglia l'abbinamento tra melaminico rovere termotrattato ed essenza rovere termotrattato Matching melamine heat-treated oak and wood veneer heat-treated oak is not recommended.

- I sensi vena dell'impiallacciatura e della finitura materica (indicati con le frecce) seguono sempre la lunghezza del pannello  
 - The direction of the veneer grain and finish material (indicated by the arrows) always follows the length of the panel.

codice code	lacc. opaco matt lacq.	essenza cat. 1 wood cat. 1	essenza cat. 2 wood cat. 2	rovere lacc. matt lacq. oak	lacc. lucido glossy lacq.	materico rovere termo. heat-treat. oak
					superfici UP UP surface	heat-treat. oak textured f.

Schiene L. 130  
Backs L. 130

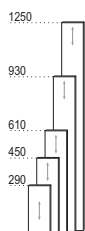

VOLm³ Kg

0,003	0,5	H. 290	SP1S12111	<b>19</b>	<b>26</b>	<b>31</b>	<b>32</b>	<b>21</b>	<b>18</b>
0,004	0,7	H. 450	SP1S12112	<b>23</b>	<b>34</b>	<b>39</b>	<b>42</b>	<b>29</b>	<b>22</b>
0,006	0,8	H. 610	SP1S12113	<b>29</b>	<b>40</b>	<b>47</b>	<b>49</b>	<b>33</b>	<b>24</b>
0,009	1,2	H. 930	SP1S12114	<b>36</b>	<b>54</b>	<b>63</b>	<b>66</b>	<b>45</b>	<b>31</b>
0,011	1,5	H. 1250	SP1S12115	<b>46</b>	<b>66</b>	<b>77</b>	<b>80</b>	<b>56</b>	<b>36</b>

Schiene L. 290  
Backs L. 290

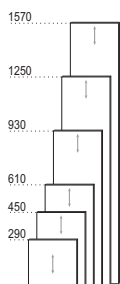

VOLm³ Kg

0,006	0,9	H. 290	SP1S12121	<b>27</b>	<b>33</b>	<b>38</b>	<b>40</b>	<b>32</b>	<b>23</b>
0,008	1,2	H. 450	SP1S12122	<b>34</b>	<b>40</b>	<b>47</b>	<b>50</b>	<b>43</b>	<b>26</b>
0,011	1,7	H. 610	SP1S12123	<b>42</b>	<b>52</b>	<b>61</b>	<b>65</b>	<b>51</b>	<b>33</b>
0,017	2,5	H. 930	SP1S12124	<b>54</b>	<b>65</b>	<b>75</b>	<b>80</b>	<b>70</b>	<b>38</b>
0,022	3,2	H. 1250	SP1S12125	<b>67</b>	<b>84</b>	<b>97</b>	<b>104</b>	<b>88</b>	<b>47</b>
0,028	4	H. 1570	SP1S12128	<b>80</b>	<b>97</b>	<b>112</b>	<b>120</b>	<b>106</b>	<b>52</b>

Schiene L. 450  
Backs L. 450

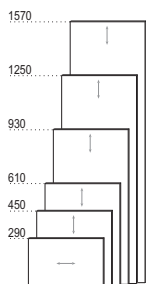

VOLm³ Kg

0,008	1,2	H. 290	SP1S12122	<b>34</b>	<b>40</b>	<b>47</b>	<b>50</b>	<b>43</b>	<b>26</b>
0,012	1,9	H. 450	SP1S12142	<b>44</b>	<b>54</b>	<b>63</b>	<b>67</b>	<b>56</b>	<b>33</b>
0,017	2,5	H. 610	SP1S12143	<b>53</b>	<b>65</b>	<b>75</b>	<b>80</b>	<b>69</b>	<b>37</b>
0,025	3,7	H. 930	SP1S12144	<b>71</b>	<b>87</b>	<b>100</b>	<b>108</b>	<b>94</b>	<b>47</b>
0,033	4,9	H. 1250	SP1S12145	<b>89</b>	<b>107</b>	<b>124</b>	<b>134</b>	<b>121</b>	<b>56</b>
0,041	6,1	H. 1570	SP1S12148	<b>110</b>	<b>131</b>	<b>152</b>	<b>166</b>	<b>150</b>	<b>65</b>

N.B: Si sconsiglia l'abbinamento tra melaminico rovere termotrattato ed essenza rovere termotrattato | Matching melamine heat-treated oak and wood veneer heat-treated oak is not recommended.

- I sensi vena dell'impiallacciatura e della finitura materica (indicati con le frecce) seguono sempre la lunghezza del pannello  
 - The direction of the veneer grain and finish material (indicated by the arrows) always follows the length of the panel.

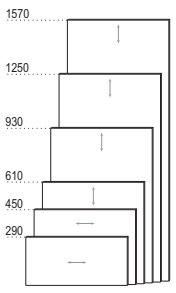
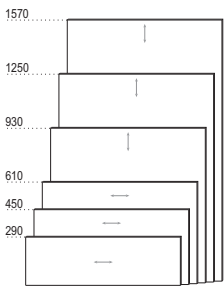
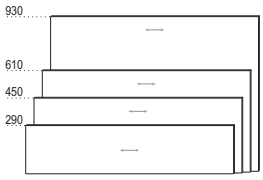
			codice code	lacc. opaco matt lacq.	essenza cat. 1 wood cat. 1	essenza cat. 2 wood cat. 2	rovere lacc. matt lacq. oak	lacc. lucido glossy lacq.	materico rovere termo. heat-treat. oak textured f.
<p>Schiene L. 610 Backs L. 610</p> 									
	VOLm³	Kg							
	0,011	1,7	H. 290	SP1S12123	42	52	61	65	33
	0,017	2,5	H. 450	SP1S12143	53	65	75	80	37
	0,022	3,2	H. 610	SP1S12163	66	80	93	101	44
	0,033	4,9	H. 930	SP1S12164	91	105	121	132	54
	0,044	6,5	H. 1250	SP1S12165	115	129	148	164	64
	0,055	8,1	H. 1570	SP1S12168	144	157	181	199	75
<p>Schiene L. 930 Backs L. 930</p> 									
	VOLm³	Kg							
	0,017	2,5	H. 290	SP1S12124	54	65	75	80	38
	0,025	3,7	H. 450	SP1S12144	71	87	100	108	47
	0,033	4,9	H. 610	SP1S12164	91	105	121	132	54
	0,049	7,4	H. 930	SP1S12184	135	143	165	182	71
	0,065	9,8	H. 1250	SP1S12185	172	178	205	227	85
	0,081	12,2	H. 1570	SP1S12188	214	213	246	274	98
<p>Schiene L. 1250 Backs L. 1250</p> 									
	VOLm³	Kg							
	0,022	3,2	H. 290	SP1S12125	67	84	97	104	47
	0,033	4,9	H. 450	SP1S12145	89	107	124	134	56
	0,044	6,5	H. 610	SP1S12165	115	129	148	164	64
	0,065	9,8	H. 930	SP1S12185	172	178	205	227	85

**UTILIZZO DI MEDIACENTER SOPRA LIBRERIE | USE OF THE MEDIACENTER ON BOOKCASES**

- Su richiesta disponibile con copriforo passacavi Ø 80 optional oppure con una pantografatura sulla schiena.
- Attenzione: nella libreria sotto il mediacenter utilizzare sempre la **divisione a terra** che permette di scaricare a terra il peso.
- Nella larghezza 1570 il vano deve essere suddiviso in tre, poichè con una divisione centrale si determinerebbe un modulo non disponibile di serie.
- An optional 80 mm-diameter hole-cover or pantograph can on request, be fitted onto the back panel.
- Attention: Always use the free-standing central partition under the mediacenter for the bookcase, as this allows the weight to be supported.
- In the L. 1570 version, the compartment must be divided into three parts, since a central partition would create a module which is not available as standard.

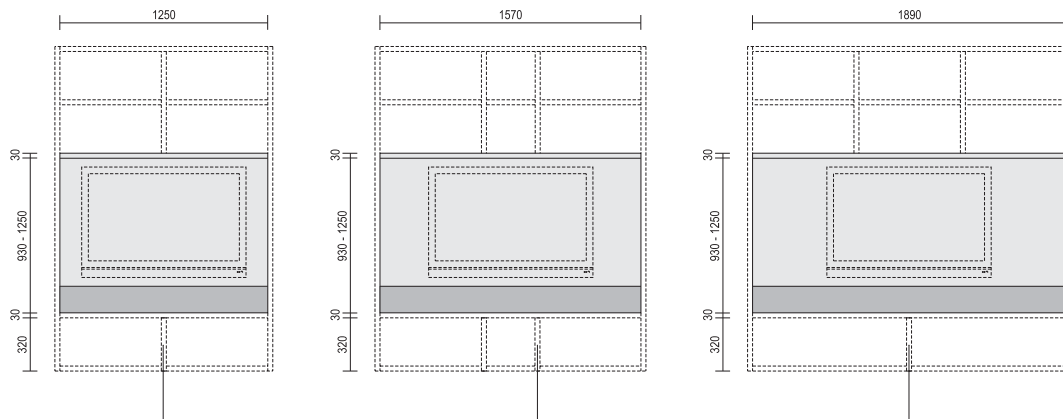

I ripiani di lunghezza superiore a 930 devono essere supportati dalla **DIVISIONE A TERRA**  
Shelves longer than 930 mm must be supported by a **FREE-STANDING PARTITION**

**UTILIZZO DI MEDIACENTER SOPRA LE BASI | USE OF THE MEDIACENTER ON BASES**

- Su richiesta disponibile con copriforo passacavi Ø 80 optional oppure con una pantografatura sulla schiena.
- Nella larghezza 1570 il vano deve essere suddiviso in tre, poichè con una divisione centrale si determinerebbe un modulo non disponibile di serie.
- An optional 80 mm-diameter hole-cover or pantograph can on request, be fitted onto the back panel.
- In the L. 1570 version, the compartment must be divided into three parts, since a central partition would create a module which is not available as standard.

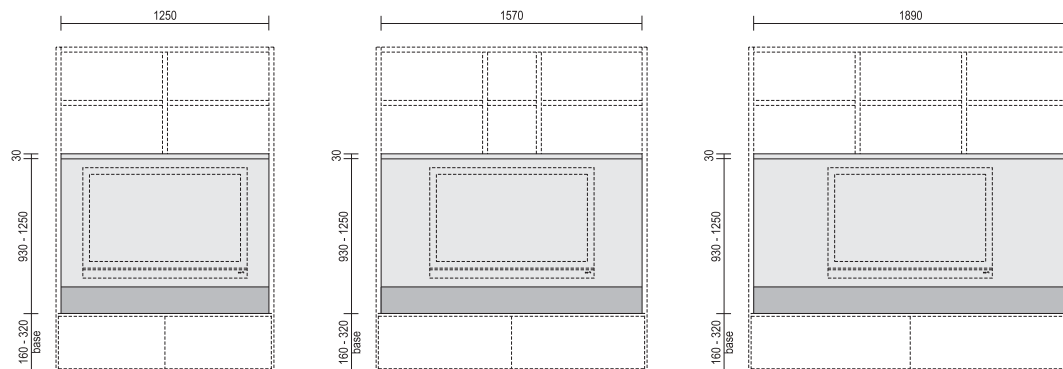

**SEZIONI LATERALI MEDIACENTER | MEDIACENTER SIDE SECTIONS**

- Sistema con schienale studiato per il fissaggio di televisori senza braccetti o supporti orientabili
- Back panel system, designed to secure the TV without using arms or rotating brackets.

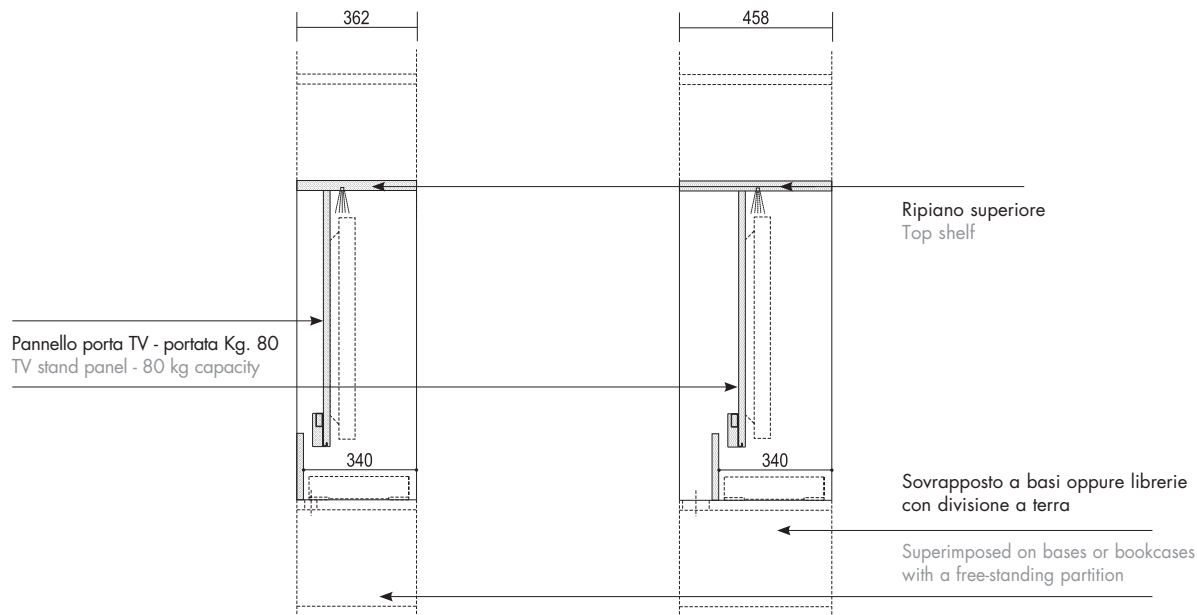

**ELETRIFICAZIONE SUL MEDIACENTER | *MEDIACENTER ELECTRIFICATION***

**ELETRIFICAZIONE APPARECCHI AUDIO/VIDEO-MEDIACENTER SOPRA LE BASI  
ELECTRIFICATION OF AUDIO/VIDEO APPLIANCES POSITIONED ON THE BASES**

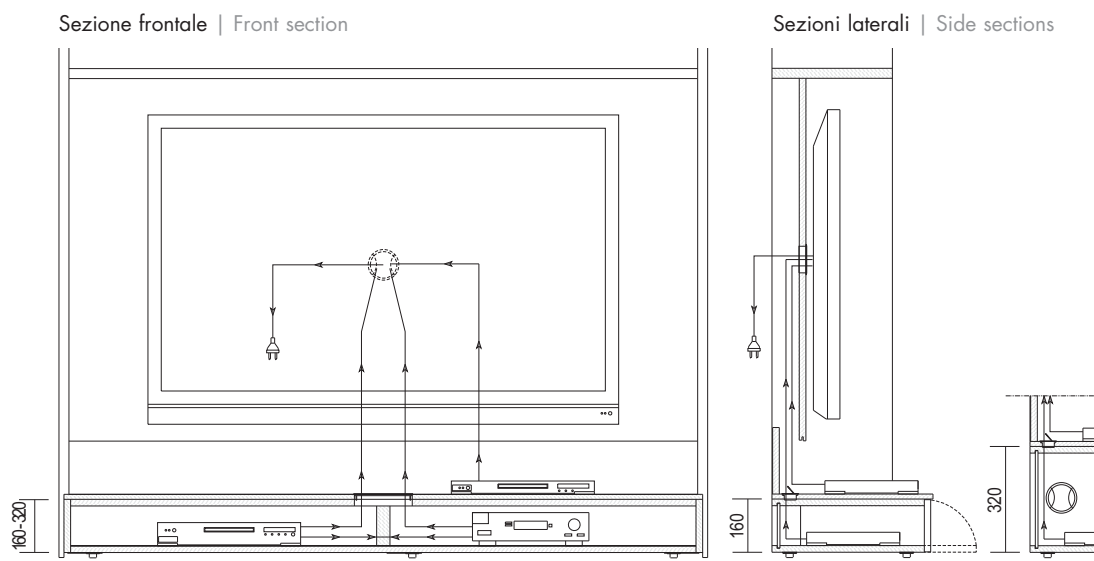

È necessario un foro con passacavi sul top della base e uno nello schienale del mediacenter, un foro con passacavi nel divisorio tra i due vani della base H.320 (lavorazioni con maggiorazione); nel caso invece di basi H.160 il divisorio termina prima della schiena e quindi vi è un'apertura utilizzabile per il passaggio dei cavi.

A cable duct hole-cover is required on the top of the base and one in the back piece of the mediacenter, a cable duct hole-cover must be made in the partition between the two compartments of the base H.320 (machining with a surcharge); in case of bases h.160, the partition ends before the back so there is an opening that can be used for the passage of the cables.



**ELETRIFICAZIONE APPARECCHI AUDIO/VIDEO - MEDIACENTER SOPRA LIBRERIA P.362**  
**ELECTRIFICATION OF AUDIO/VIDEO APPLIANCES ON 362 MM-DEEP BASE UNITS**

Sezione frontale | Front section

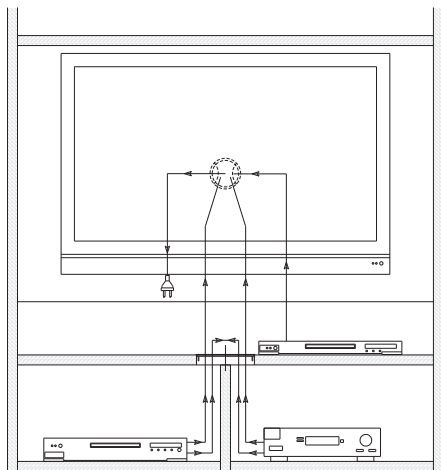

Sezione laterale | Side section

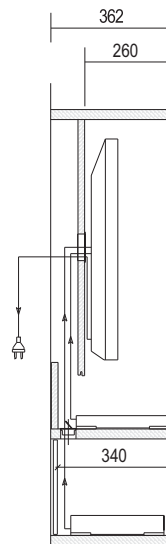

È necessario un foro con passacavi centrale sul ripiano e uno sullo schienale del mediacenter (lavorazioni con maggiorazione), mentre non è possibile l'inserimento di passacavi nella divisione centrale.  
 One central cable duct hole-cover is necessary on the shelf and one on the back panel of the mediacenter (machining with a surcharge), while it is not possible to include cable ducts in the central partition.

**ELETRIFICAZIONE APPARECCHI AUDIO/VIDEO - MEDIACENTER SOPRA LIBRERIA P.458**  
**ELECTRIFICATION OF AUDIO/VIDEO APPLIANCES ABOVE THE 458 MM-DEEP BOOKCASE**

Sezione frontale | Front section

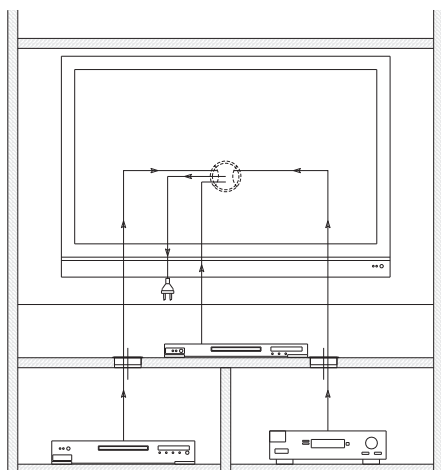

Sezione laterale | Side section

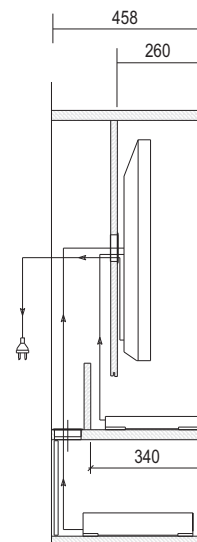

Sono necessari due fori con passacavi sul ripiano e uno sullo schienale del mediacenter (lavorazioni con maggiorazione), mentre non è possibile l'inserimento di passacavi nella divisione centrale.  
 Two cable duct hole-covers are necessary on the shelf and one on the back panel of the mediacenter (machining with a surcharge), while it is not possible to include cable ducts in the central partition.

N.B: Si sconsiglia l'abbinamento tra melaminico rovere termotrattato ed essenza rovere termotrattato | Matching melamine heat-treated oak and wood veneer heat-treated oak is not recommended.

- Su richiesta disponibile con copriforo passacavi Ø 80 o pantografatura  
- An 80 mm-diameter hole-cover or pantograph is available on request.

	codice code	lacc. opaco matt lacq.	essenza cat. 1 wood cat. 1	essenza cat. 2 wood cat. 2	rovere lacc. matt lacq. oak	lacc. lucido glossy lacq. superfici UP UP surface	materico rovere termo. heat-treat. oak textured f.		
<b>Mediacer H. 930</b> Mediacer H. 930									
	VOLm³ Kg P.   D. 362								
	0,124	30	L. 1250 SP1M01365	<b>298</b>	<b>480</b>	<b>568</b>	<b>608</b>	<b>453</b>	<b>236</b>
	0,153	37	L. 1570 SP1M01375	<b>373</b>	<b>570</b>	<b>672</b>	<b>725</b>	<b>567</b>	<b>291</b>
	0,184	44	L. 1890 SP1M01385	<b>455</b>	<b>725</b>	<b>856</b>	<b>917</b>	<b>690</b>	<b>363</b>
	VOLm³ Kg P.   D. 458								
	0,133	32,5	L. 1250 SP1M01465	<b>312</b>	<b>504</b>	<b>597</b>	<b>643</b>	<b>484</b>	<b>245</b>
	0,164	40	L. 1570 SP1M01475	<b>390</b>	<b>600</b>	<b>709</b>	<b>768</b>	<b>602</b>	<b>301</b>
	0,197	48	L. 1890 SP1M01485	<b>475</b>	<b>762</b>	<b>899</b>	<b>968</b>	<b>733</b>	<b>376</b>
	Copriforo   Hole-cover optional		A99011	<b>20</b>					
	Lavorazione per copriforo o pantografatura Machining for the hole-cover or pantograph			<b>49</b>					
<b>Mediacer H. 1250</b> Mediacer H. 1250									
	VOLm³ Kg P.   D. 362								
	0,140	34,5	L. 1250 SP1M01366	<b>334</b>	<b>539</b>	<b>636</b>	<b>684</b>	<b>522</b>	<b>259</b>
	0,184	43	L. 1570 SP1M01376	<b>415</b>	<b>655</b>	<b>772</b>	<b>834</b>	<b>650</b>	<b>319</b>
	0,222	51,5	L. 1890 SP1M01386	<b>507</b>	<b>816</b>	<b>963</b>	<b>1036</b>	<b>792</b>	<b>402</b>
	VOLm³ Kg P.   D. 458								
	0,149	37	L. 1250 SP1M01466	<b>348</b>	<b>563</b>	<b>665</b>	<b>719</b>	<b>553</b>	<b>268</b>
	0,195	45,5	L. 1570 SP1M01476	<b>432</b>	<b>685</b>	<b>809</b>	<b>877</b>	<b>685</b>	<b>329</b>
	0,235	55	L. 1890 SP1M01486	<b>527</b>	<b>853</b>	<b>1006</b>	<b>1087</b>	<b>835</b>	<b>415</b>
	Copriforo   Hole-cover optional		A99011	<b>20</b>					
	Lavorazione per copriforo o pantografatura Machining for the hole-cover or pantograph			<b>49</b>					
<b>Divisione a terra</b> Free-standing partition									
	VOLm³ Kg P.   D. 362								
	0,010	2,5	H. 320 SP1S3D31A	<b>49</b>	<b>74</b>	<b>89</b>	<b>94</b>	<b>69</b>	<b>44</b>
	0,015	3,6	H. 480 SP1S3D31B	<b>60</b>	<b>88</b>	<b>106</b>	<b>114</b>	<b>85</b>	<b>50</b>
	0,019	4,5	H. 640 SP1S3D31D	<b>69</b>	<b>102</b>	<b>123</b>	<b>132</b>	<b>102</b>	<b>57</b>
	0,028	7	H. 960 SP1S3D31F	<b>84</b>	<b>130</b>	<b>156</b>	<b>170</b>	<b>134</b>	<b>65</b>
	0,037	9,5	H. 1280 SP1S3D31H	<b>101</b>	<b>157</b>	<b>188</b>	<b>207</b>	<b>158</b>	<b>74</b>
	VOLm³ Kg P.   D. 458								
	0,013	3	H. 320 SP1S3D41A	<b>54</b>	<b>83</b>	<b>100</b>	<b>106</b>	<b>78</b>	<b>49</b>
	0,018	4,7	H. 480 SP1S3D41B	<b>66</b>	<b>99</b>	<b>119</b>	<b>129</b>	<b>100</b>	<b>57</b>
	0,024	6	H. 640 SP1S3D41D	<b>76</b>	<b>116</b>	<b>140</b>	<b>152</b>	<b>120</b>	<b>63</b>
0,035	9	H. 960 SP1S3D41F	<b>97</b>	<b>146</b>	<b>175</b>	<b>193</b>	<b>159</b>	<b>76</b>	
0,046	11,5	H. 1280 SP1S3D41H	<b>116</b>	<b>178</b>	<b>213</b>	<b>236</b>	<b>197</b>	<b>86</b>	

N.B: Si consiglia l'abbinamento tra melaminico rovere termotrattato ed essenza rovere termotrattato | Matching melamine heat-treated oak and wood veneer heat-treated oak is not recommended.

- Su richiesta disponibile con copriforo passacavi Ø 80 o pantografatura - An 80 mm-diameter hole-cover or pantograph is available on request.	codice	lacc. opaco	essenza cat. 1	essenza cat. 2	rovere lacc.	lacc. lucido	materico
	code	matt lacq.	wood cat. 1	wood cat. 2	matt lacq. oak	glossy lacq.	rovere termo.

Schienale per TV H. 930  
TV back panel H. 930

VOLm³ Kg P. | D. 362

0,115 29	L. 1250	SP1M02365	264	434	513	554	420	209
0,144 36	L. 1570	SP1M02375	332	527	622	673	526	259
0,172 43	L. 1890	SP1M02385	412	672	794	855	648	334

VOLm³ Kg P. | D. 458

0,125 31	L. 1250	SP1M02465	278	458	542	589	451	218
0,155 39	L. 1570	SP1M02475	349	557	659	716	561	269
0,185 46,5	L. 1890	SP1M02485	432	709	837	906	691	347

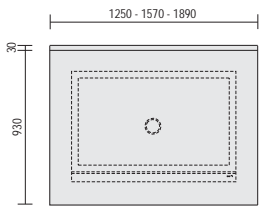

Copriforo | Hole-cover optional A99011 20  
Lavorazione per copriforo o pantografatura  
Machining for the hole-cover or pantograph 49

Schienale per TV H. 1250  
TV back panel H. 1250

VOLm³ Kg P. | D. 362

0,141 34	L. 1250	SP1M02366	304	520	613	660	487	225
0,175 42,5	L. 1570	SP1M02376	383	631	743	801	610	278
0,209 51	L. 1890	SP1M02386	475	808	953	1024	752	359

VOLm³ Kg P. | D. 458

0,150 36	L. 1250	SP1M02466	318	544	642	695	518	234
0,186 45	L. 1570	SP1M02476	400	661	780	844	645	288
0,222 54,5	L. 1890	SP1M02486	495	845	996	1075	795	372

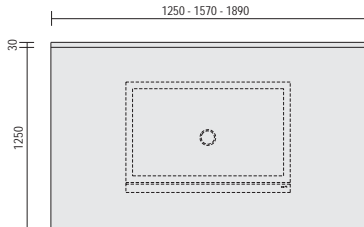

Copriforo | Hole-cover optional A99011 20  
Lavorazione per copriforo o pantografatura  
Machining for the hole-cover or pantograph 49

- Schienale studiato per il fissaggio di televisori senza braccetti o supporti orientabili.

- Back panel system, designed to secure the TV without using arms or rotating brackets.

Pannello porta TV - portata Kg. 80  
TV stand panel - 80 kg capacity

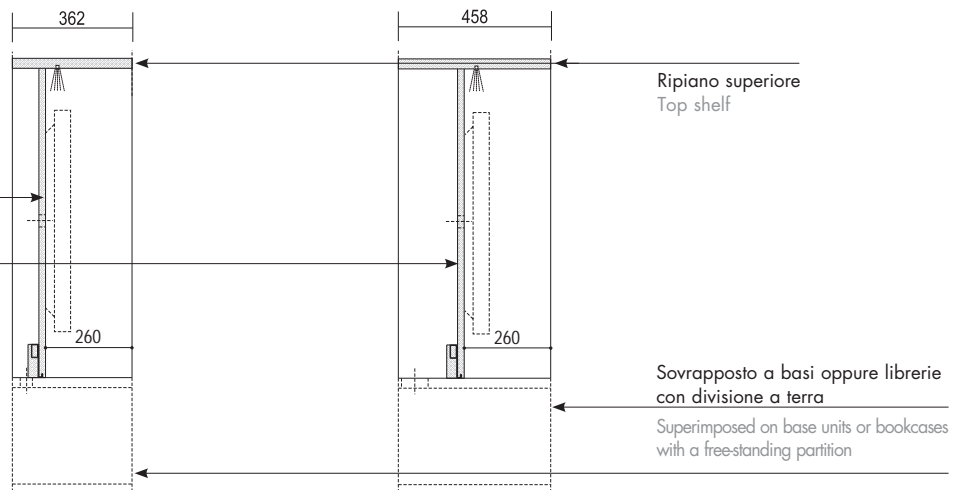

# CASSETTI E CESTONI IN LUCE | FLUSH-FRONT DRAWERS AND DEEP DRAWERS P. | D. 362 - 458

N.B: Si sconsiglia l'abbinamento tra melaminico rovere termotrattato ed essenza rovere termotrattato | Matching melamine heat-treated oak and wood veneer heat-treated oak is not recommended.

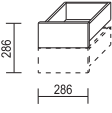
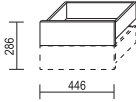
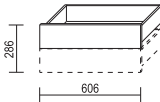
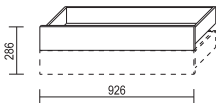
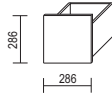
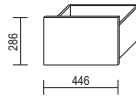
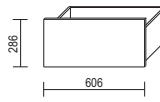
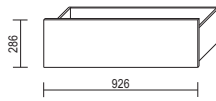
- Cassetti e cestoni in luce disponibili solo con apertura "push and pull" - The flush-front drawers and deep drawers are available with "push and pull" opening only		codice code	lacc. opaco matt lacq.	essenza cat. 1 wood cat. 1	essenza cat. 2 wood cat. 2	rovere lacc. matt lacq. oak	lacc. lucido glossy lacq.	materico rovere termo. heat-treat. oak textured f.	
									superfici UP UP surface
Cassetti per vano L. 290 - prezzo relativo ad 1 cassetto Drawers for compartment L. 290 - price refers to 1 drawer									
	VOL.m <sup>3</sup> Kg 0,038 4,2	P.   D. 362	SP1C21311	67	72	83	85	74	63
	0,049 4,9	P.   D. 458	SP1C21411	71	76	88	90	78	66
Cassetti per vano L. 450 - prezzo relativo ad 1 cassetto Drawers for compartment L. 450 - price refers to 1 drawer									
	VOL.m <sup>3</sup> Kg 0,057 5,9	P.   D. 362	SP1C21321	74	80	93	97	81	67
	0,072 6,8	P.   D. 458	SP1C21421	78	84	97	100	86	71
Cassetti per vano L. 610 - prezzo relativo ad 1 cassetto Drawers for compartment L. 610 - price refers to 1 drawer									
	VOL.m <sup>3</sup> Kg 0,075 7,5	P.   D. 362	SP1C21331	87	100	115	119	98	78
	0,096 8,5	P.   D. 458	SP1C21431	90	100	115	119	101	80
Cassetti per vano L. 930 - prezzo relativo ad 1 cassetto Drawers for compartment L. 930 - price refers to 1 drawer									
	VOL.m <sup>3</sup> Kg 0,113 10,5	P.   D. 362	SP1C21341	107	119	138	143	123	96
	0,144 12	P.   D. 458	SP1C21441	112	124	143	148	126	100
Cestone per vano L. 290 Deep drawer for compartment L. 290									
	VOL.m <sup>3</sup> Kg 0,038 3,8	P.   D. 362	SP1C21312	74	84	97	100	87	66
	0,049 4,3	P.   D. 458	SP1C21412	78	88	102	105	90	70
Cestone per vano L. 450 Deep drawer for compartment L. 450									
	VOL.m <sup>3</sup> Kg 0,057 5,1	P.   D. 362	SP1C21322	83	96	111	116	99	73
	0,072 5,8	P.   D. 458	SP1C21422	87	100	115	120	103	76
Cestone per vano L. 610 Deep drawer for compartment L. 610									
	VOL.m <sup>3</sup> Kg 0,075 6,3	P.   D. 362	SP1C21332	100	115	132	140	119	87
	0,096 7,2	P.   D. 458	SP1C21432	104	119	138	145	124	90
Cestone per vano L. 930 Deep drawer for compartment L. 930									
	VOL.m <sup>3</sup> Kg 0,113 8,8	P.   D. 362	SP1C21342	124	143	165	175	153	106
	0,144 10	P.   D. 458	SP1C21442	129	150	172	183	158	112

N.B: Si sconsiglia l'abbinamento tra melaminico rovere termotrattato ed essenza rovere termotrattato | Matching melamine heat-treated oak and wood veneer heat-treated oak is not recommended.

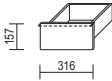
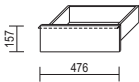
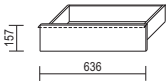
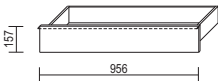
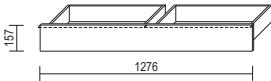
- Apertura standard "push and pull"   Standard "Push and pull" opening	codice code	lacc. opaco matt lacq.	essenza cat. 1 wood cat. 1	essenza cat. 2 wood cat. 2	rovere lacc. matt lacq. oak	lacc. lucido glossy lacq.	materico rovere termo. heat-treat. oak textured f.	maniglia Slim handle	maniglia gola Groove handle
Cassetto per vano L. 290 Drawer for compartment L. 290  									
	VOL.m³ Kg								
	0,025 2,6 P.   D. 362	SP1C20311	66	71	83	86	72	62	5
0,032 2,9 P.   D. 458	SP1C20411	70	75	88	91	76	65	5	29
Cassetto per vano L. 450 Drawer for compartment L. 450  									
	VOL.m³ Kg								
	0,037 3,3 P.   D. 362	SP1C20321	73	79	93	99	80	66	6
0,047 3,8 P.   D. 458	SP1C20421	77	87	99	104	84	70	6	32
Cassetto per vano L. 610 Drawer for compartment L. 610  									
	VOL.m³ Kg								
	0,048 4,1 P.   D. 362	SP1C20331	85	94	111	117	96	76	7
0,061 4,6 P.   D. 458	SP1C20431	89	103	119	126	100	79	7	35
Cassetto per vano L. 930 Drawer for compartment L. 930  									
	VOL.m³ Kg								
	0,071 5,8 P.   D. 362	SP1C20341	106	119	141	151	121	94	8
0,090 6,5 P.   D. 458	SP1C20441	110	128	148	157	126	98	8	39
Cassetti per vano L. 1250 - frontale unico Drawers for compartment L. 1250 - single front part  									
	VOL.m³ Kg								
	0,093 7,7 P.   D. 362	SP1C20351	179	192	225	238	197	158	12
0,119 8,7 P.   D. 458	SP1C20451	183	206	237	250	201	161	12	43

N.B: Si sconsiglia l'abbinamento tra melaminico rovere termotrattato ed essenza rovere termotrattato | Matching melamine heat-treated oak and wood veneer heat-treated oak is not recommended.

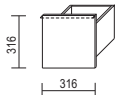
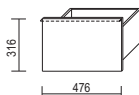
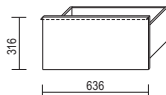
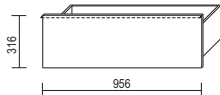
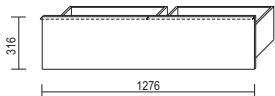
- Apertura standard "push and pull"   Standard "Push and pull" opening	codice code	lacc. opaco matt lacq.	essenza cat. 1 wood cat. 1	essenza cat. 2 wood cat. 2	rovere lacc. matt lacq. oak	lacc. lucido glossy lacq.	materico rovere termo. heat-treat. oak textured f.	maniglia Slim handle	maniglia gola Groove handle
<b>Cestone per vano L. 290</b> Deep drawer for compartment L. 290 									
VOLm <sup>3</sup> Kg									
0,046 4,1 P.   D. 362	SP1C20312	<b>74</b>	<b>78</b>	<b>92</b>	<b>99</b>	<b>86</b>	<b>66</b>	<b>5</b>	<b>29</b>
0,058 4,6 P.   D. 458	SP1C20412	<b>78</b>	<b>87</b>	<b>102</b>	<b>108</b>	<b>91</b>	<b>70</b>	<b>5</b>	<b>29</b>
<b>Cestone per vano L. 450</b> Deep drawer for compartment L. 450 									
VOLm <sup>3</sup> Kg									
0,066 5,4 P.   D. 362	SP1C20322	<b>84</b>	<b>90</b>	<b>105</b>	<b>115</b>	<b>99</b>	<b>73</b>	<b>6</b>	<b>32</b>
0,085 6,1 P.   D. 458	SP1C20422	<b>87</b>	<b>102</b>	<b>119</b>	<b>125</b>	<b>103</b>	<b>76</b>	<b>6</b>	<b>32</b>
<b>Cestone per vano L. 610</b> Deep drawer for compartment L. 610 									
VOLm <sup>3</sup> Kg									
0,087 6,7 P.   D. 362	SP1C20332	<b>101</b>	<b>106</b>	<b>126</b>	<b>138</b>	<b>119</b>	<b>87</b>	<b>7</b>	<b>35</b>
0,111 7,5 P.   D. 458	SP1C20432	<b>104</b>	<b>125</b>	<b>144</b>	<b>151</b>	<b>123</b>	<b>90</b>	<b>7</b>	<b>35</b>
<b>Cestone per vano L. 930</b> Deep drawer for compartment L. 930 									
VOLm <sup>3</sup> Kg									
0,128 9,4 P.   D. 362	SP1C20342	<b>126</b>	<b>134</b>	<b>164</b>	<b>180</b>	<b>153</b>	<b>107</b>	<b>8</b>	<b>39</b>
0,163 10,4 P.   D. 458	SP1C20442	<b>130</b>	<b>159</b>	<b>188</b>	<b>198</b>	<b>157</b>	<b>112</b>	<b>8</b>	<b>39</b>
<b>Cestoni per vano L. 1250 - frontale unico</b> Deep drawers for unit L. 1250 - single front part 									
VOLm <sup>3</sup> Kg									
0,169 13 P.   D. 362	SP1C20352	<b>198</b>	<b>207</b>	<b>247</b>	<b>269</b>	<b>234</b>	<b>167</b>	<b>12</b>	<b>43</b>
0,216 14,6 P.   D. 458	SP1C20452	<b>204</b>	<b>241</b>	<b>279</b>	<b>295</b>	<b>239</b>	<b>172</b>	<b>12</b>	<b>43</b>

N.B: Si sconsiglia l'abbinamento tra melaminico rovere termotrattato ed essenza rovere termotrattato | Matching melamine heat-treated oak and wood veneer heat-treated oak is not recommended.

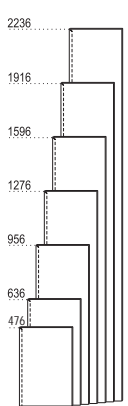
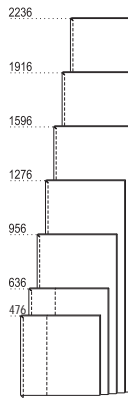
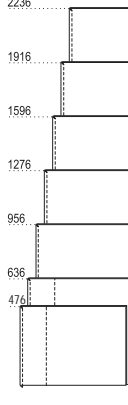
- I sensi vena dell'impiallacciatura e della finitura materica sono sempre verticali. - The direction of the veneer grain and finish material is always vertical. - Apertura standard "push and pull"   Standard "Push and pull" opening		codice code	lacc. opaco matt lacq.	essenza cat. 1 wood cat. 1	essenza cat. 2 wood cat. 2	rovere lacc. matt lacq. oak	lacc. lucido glossy lacq.	materico rovere termo. heat-treat. oak textured f.	maniglia Slim handle	maniglia gola Groove handle	maniglia XL handle	
												superfici UP UP surface
<p>Ante battenti L. 316 specificare nell'ordine se apertura dx o sx Hinged doors L. 316 specify in the order if lh or rh opening</p> 												
VOL.m³ Kg												
	0,010 2,3	H. 476	SP1A20223	53	72	83	87	70	40	10	37	-
	0,014 3	H. 636	SP1A20224	61	83	96	101	79	44	11	39	-
	0,020 4,2	H. 956	SP1A20225	80	108	126	132	107	54	17	46	-
	0,026 6	H. 1276	SP1A20226	101	137	158	167	135	64	21	51	-
	0,033 6,8	H. 1596	SP1A20227	116	159	184	196	159	71	27	58	-
	0,040 8,2	H. 1916	SP1A20228	129	180	209	222	183	76	33	64	-
	0,049 10,5	H. 2236	SP1A20229	152	209	242	269	212	87	39	72	-
<p>Ante battenti L. 476 specificare nell'ordine se apertura dx o sx Hinged doors L. 476 specify in the order if lh or rh opening</p> 												
VOL.m³ Kg												
	0,015 3,3	H. 476	SP1A20243	67	89	102	110	90	50	10	37	38
	0,021 4,2	H. 636	SP1A20244	74	101	117	127	104	53	11	39	44
	0,031 6,2	H. 956	SP1A20245	100	139	160	172	140	67	17	46	-
	0,041 8,2	H. 1276	SP1A20246	126	173	201	216	180	79	21	51	-
	0,051 10,2	H. 1596	SP1A20247	147	206	238	255	213	90	27	58	-
	0,061 12,2	H. 1916	SP1A20248	165	237	274	296	246	98	33	64	-
	0,071 14,2	H. 2236	SP1A20249	193	272	316	357	285	111	39	72	-
<p>Ante battenti L. 636 specificare nell'ordine se apertura dx o sx Hinged doors L. 636 specify in the order if lh or rh opening</p> 												
VOL.m³ Kg												
	0,019 4,3	H. 476	SP1A20263	74	101	117	127	104	56	10	37	38
	0,027 5,7	H. 636	SP1A20264	85	119	139	151	124	61	11	39	44
	0,040 8,2	H. 956	SP1A20265	118	167	193	211	173	79	17	46	-
	0,053 10,7	H. 1276	SP1A20266	151	213	247	269	222	94	21	51	-
	0,066 13,7	H. 1596	SP1A20267	177	251	292	319	266	107	27	58	-
	0,079 16,2	H. 1916	SP1A20268	201	292	339	370	306	119	33	64	-
	0,092 18,2	H. 2236	SP1A20269	232	337	391	445	357	133	39	72	-

N.B: Si sconsiglia l'abbinamento tra melaminico rovere termotrattato ed essenza rovere termotrattato | Matching melamine heat-treated oak and wood veneer heat-treated oak is not recommended.

- Solo apertura "push and pull" | "Push and pull" opening only

codice code	vetro cat. 1 glass cat. 1	vetro cat. 2 glass cat. 2
-------------	---------------------------	---------------------------

Ante vetro SLIM battenti L. 316  
specificare nell'ordine se apertura dx o sx  
Hinged glass SLIM doors L. 316  
specify in the order if lh or rh opening

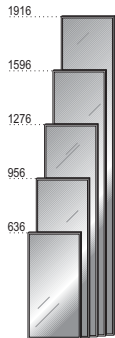

VOLm³	Kg				
0,015	4	H. 636	SP1A21224	<b>164</b>	<b>189</b>
0,022	5,5	H. 956	SP1A21225	<b>216</b>	<b>250</b>
0,029	7	H. 1276	SP1A21226	<b>268</b>	<b>309</b>
0,036	8,5	H. 1596	SP1A21227	<b>301</b>	<b>357</b>
0,043	10	H. 1916	SP1A21228	<b>333</b>	<b>404</b>

Ante vetro SLIM battenti L. 476  
specificare nell'ordine se apertura dx o sx  
Hinged glass SLIM doors L. 476  
specify in the order if lh or rh opening

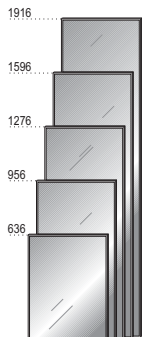

VOLm³	Kg				
0,022	5,5	H. 636	SP1A21244	<b>192</b>	<b>227</b>
0,032	8	H. 956	SP1A21245	<b>252</b>	<b>307</b>
0,042	10	H. 1276	SP1A21246	<b>315</b>	<b>389</b>
0,052	12,5	H. 1596	SP1A21247	<b>355</b>	<b>448</b>
0,063	14,5	H. 1916	SP1A21248	<b>398</b>	<b>506</b>

Ante vetro SLIM battenti L. 636  
specificare nell'ordine se apertura dx o sx  
Hinged glass SLIM doors L. 636  
specify in the order if lh or rh opening

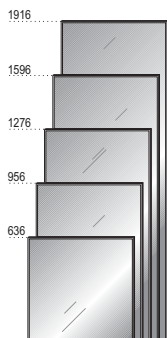

VOLm³	Kg				
0,028	7	H. 636	SP1A21264	<b>219</b>	<b>265</b>
0,042	10	H. 956	SP1A21265	<b>290</b>	<b>368</b>
0,055	13,5	H. 1276	SP1A21266	<b>358</b>	<b>468</b>
0,069	16,5	H. 1596	SP1A21267	<b>411</b>	<b>539</b>
0,082	19,5	H. 1916	SP1A21268	<b>463</b>	<b>609</b>



N.B: Si sconsiglia l'abbinamento tra melaminico rovere termotrattato ed essenza rovere termotrattato | Matching melamine heat-treated oak and wood veneer heat-treated oak is not recommended.

- Apertura tramite presa laterale sul telaio dell'anta, sono disponibili solo in vetro trasparente grigio  
 - Attenzione: non utilizzare il top con ante vetro UP perchè queste ante sono più profonde e sporgerebbero di 15 mm  
 - Opens via the side handle on the door's frame. Only available in transparent grey glass.  
 - Please note: Do not use the top with UP glass doors because these doors are deeper and will protrude 15 mm more.

codice code	vetro trasparenz. grigio cat. 1
	grey transp. glass cat. 1

**Ante vetro UP battenti L. 316**  
 specificare nell'ordine se apertura dx o sx  
 Hinged glass UP doors L. 316  
 specify in the order if lh or rh opening

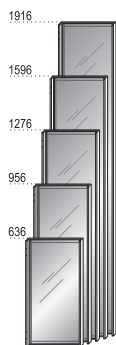

VOLm³	Kg			
0,015	4,5	H. 636	SP1A21324	<b>286</b>
0,022	6	H. 956	SP1A21325	<b>321</b>
0,029	7,5	H. 1276	SP1A21326	<b>355</b>
0,036	9	H. 1596	SP1A21327	<b>382</b>
0,043	10,5	H. 1916	SP1A21328	<b>422</b>

**Ante vetro UP battenti L. 476**  
 specificare nell'ordine se apertura dx o sx  
 Hinged glass UP doors L. 476  
 specify in the order if lh or rh opening

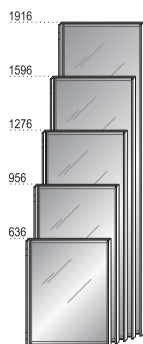

VOLm³	Kg			
0,022	6	H. 636	SP1A21344	<b>304</b>
0,032	8,5	H. 956	SP1A21345	<b>349</b>
0,042	10,5	H. 1276	SP1A21346	<b>389</b>
0,052	13	H. 1596	SP1A21347	<b>425</b>
0,063	15	H. 1916	SP1A21348	<b>472</b>

**Ante vetro UP battenti L. 636**  
 specificare nell'ordine se apertura dx o sx  
 Hinged glass UP doors L. 636  
 specify in the order if lh or rh opening

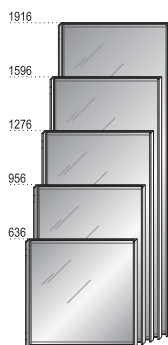

VOLm³	Kg			
0,028	7,5	H. 636	SP1A21364	<b>323</b>
0,042	10,5	H. 956	SP1A21365	<b>374</b>
0,055	14	H. 1276	SP1A21366	<b>424</b>
0,069	17	H. 1596	SP1A21367	<b>468</b>
0,082	20	H. 1916	SP1A21368	<b>524</b>



## ESEMPIO DI UTILIZZO BINARI PER ANTE SCORREVOLI | EXAMPLE OF USING TRACKS FOR SLIDING DOORS

- Il binario h. 15 si deve utilizzare esclusivamente quando sopra o sotto l'anta scorrevole sono presenti dei frontali in battuta, vedi esempi sotto riportati.  
In tutti gli altri casi utilizzare il binario h.30.
- La misura massima del binario è di L. 6080. - Non è possibile l'inserimento di ribalte con apertura verso il basso posizionate sopra l'anta scorrevole.
- The track h. 15 must be used only when jutting fronts are positioned above or below the sliding door; see the examples below.  
In all other cases, use the track h.30.
- The maximum length of the track is L. 6080. - Flap-doors with downward opening cannot be positioned above the sliding door.

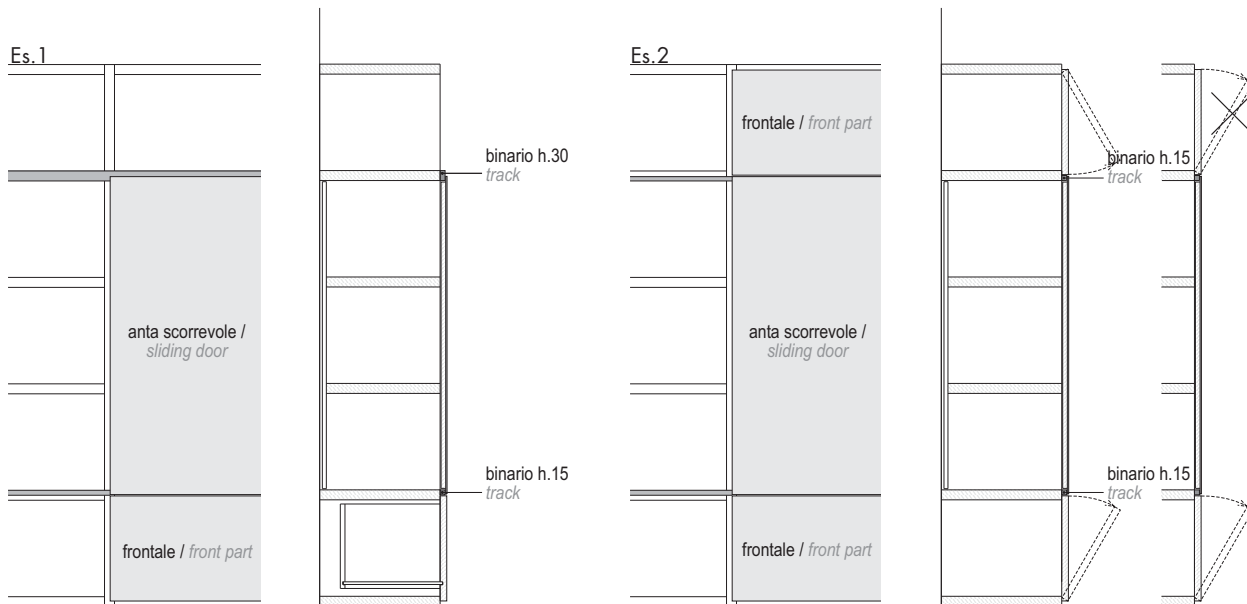

## BINARI PER ANTE SCORREVOLI | TRACKS FOR SLIDING DOORS

- Il binario è costituito da una struttura in alluminio e da una copertura disponibile in alluminio o laccata opaca in tutta la gamma colori, lunghezza max 6080. Ricordarsi di conteggiare sempre un binario superiore ed uno inferiore.

- The track is composed of an aluminium structure and a cover which is available in aluminium or a whole range of matt lacquer colours. Maximum length: 6080 mm. Remember to always count one upper track and one lower track.

codice  
code

alluminio  
aluminium

lacc. opaco  
matt lacq.

Esempio calcolo binari per scorrevole:  
Modulo 960 + 320 + 640 = L. totale binario 1920

Example calculation for sliding door tracks:  
Module 960 + 320 + 640 = track total L.1920

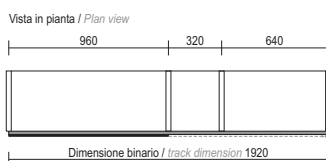

Binario H. 30  
Track

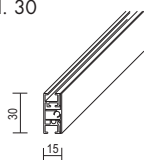

VOL.m<sup>3</sup> Kg  
0,0008 0,5

**H. 30**  
al ml. / per m.

SP1X14213

**54**

**63**

Binario H. 15  
Track

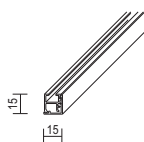

VOL.m<sup>3</sup> Kg  
0,004 0,25

**H. 15**  
al ml. / per m.

SP1X13211

**44**

**51**

- I sensi vena dell'impiallacciatura (indicati con le frecce) seguono sempre la lunghezza del pannello - Il telaio in alluminio rientrante rispetto al bordo (vedi Es.1) permette la presa senza bisogno di maniglia  
 - The direction of the veneer grain (indicated with the arrow) always follows the length of the panel - The aluminium frame is narrower than the edge (see Es.1), thus allowing the door to be grasped without the need for a handle

codice code	lacc. opaco matt lacq.	essenza cat. 1 wood cat. 1	essenza cat. 2 wood cat. 2	rovere lacc. matt lacq. oak	lacc. lucido glossy lacq.
-------------	------------------------	----------------------------	----------------------------	-----------------------------	---------------------------

Ante scorrevoli L. 955  
Sliding doors L. 955

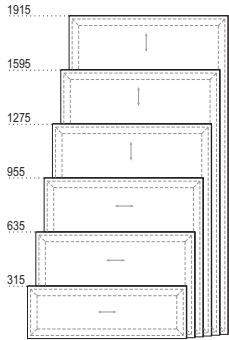
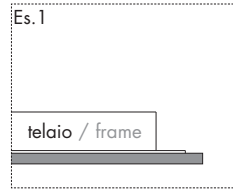

VOLm <sup>3</sup>	Kg	H.	SP1A25242	231	307	327	339	248
0,021	6,8	H. 315	SP1A25242	231	307	327	339	248
0,040	9	H. 635	SP1A25243	293	383	411	435	323
0,059	13	H. 955	SP1A25244	353	463	505	539	399
0,079	17,3	H. 1275	SP1A25245	425	549	600	646	485
0,098	21,5	H. 1595	SP1A25247	502	636	697	755	575
0,117	26	H. 1915	SP1A25248	577	723	798	868	665

Ante scorrevoli L. 1275  
Sliding doors L. 1275

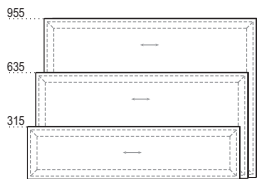

VOLm <sup>3</sup>	Kg	H.	SP1A25252	268	358	382	398	291
0,028	6,2	H. 315	SP1A25252	268	358	382	398	291
0,053	11,9	H. 635	SP1A25253	347	455	492	523	388
0,079	17,3	H. 955	SP1A25254	425	549	600	646	485

Ante scorrevoli L. 1595  
Sliding doors L. 1595



VOLm <sup>3</sup>	Kg	H.	SP1A25272	304	403	431	451	331
0,035	7,7	H. 315	SP1A25272	304	403	431	451	331
0,066	14,7	H. 635	SP1A25273	399	517	560	599	452

Ante scorrevoli L. 1915  
Sliding doors L. 1915



VOLm <sup>3</sup>	Kg	H.	SP1A25282	328	435	466	490	362
0,042	9,1	H. 315	SP1A25282	328	435	466	490	362

- Il telaio in alluminio rientrante rispetto al bordo (vedi Es.1) permette la presa senza bisogno di maniglia  
 - The aluminium frame is narrower than the edge (see Es.1), thus allowing the door to be grasped without the need for a handle  
 - Attenzione: i vetri trasparenti e stopsol fumé non sono disponibili nelle ante scorrevoli  
 - Attention: the transparents and stopsol glasses are not available for the sliding doors

codice  
code

vetro cat. 1  
glass cat. 1

vetro cat. 2  
glass cat. 2

Ante vetro scorrevoli L. 955  
Sliding glass doors L. 955

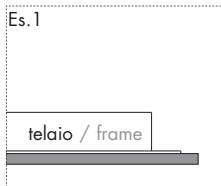
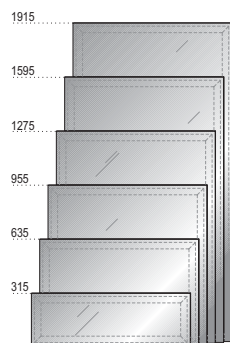

VOLm <sup>3</sup>	Kg
0,021	7,3
0,040	9,5
0,059	13,5
0,079	17,8
0,098	22
0,117	26,5

H.	codice	vetro cat. 1	vetro cat. 2
H. 315	SP1A24242	<b>233</b>	<b>273</b>
H. 635	SP1A24243	<b>304</b>	<b>381</b>
H. 955	SP1A24244	<b>376</b>	<b>489</b>
H. 1275	SP1A24245	<b>456</b>	<b>604</b>
H. 1595	SP1A24247	<b>518</b>	<b>705</b>
H. 1915	SP1A24248	<b>579</b>	<b>803</b>

Ante vetro scorrevoli L. 1275  
Sliding glass doors L. 1275

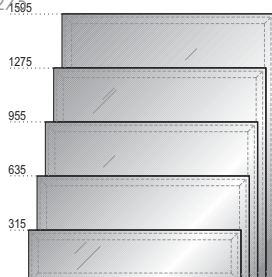

VOLm <sup>3</sup>	Kg
0,028	6,7
0,053	12,4
0,079	17,8
0,104	23
0,129	28,5

H.	codice	vetro cat. 1	vetro cat. 2
H. 315	SP1A24252	<b>272</b>	<b>320</b>
H. 635	SP1A24253	<b>364</b>	<b>463</b>
H. 955	SP1A24254	<b>456</b>	<b>604</b>
H. 1275	SP1A24255	<b>551</b>	<b>750</b>
H. 1595	SP1A24257	<b>645</b>	<b>895</b>

Ante vetro scorrevoli L. 1595  
Sliding glass doors L. 1595



VOLm <sup>3</sup>	Kg
0,035	8,2
0,066	15,2

H.	codice	vetro cat. 1	vetro cat. 2
H. 315	SP1A24272	<b>314</b>	<b>372</b>
H. 635	SP1A24273	<b>418</b>	<b>543</b>

Ante vetro scorrevoli L. 1915  
Sliding glass doors L. 1915



VOLm <sup>3</sup>	Kg
0,042	9,6

H.	codice	vetro cat. 1	vetro cat. 2
H. 315	SP1A24282	<b>334</b>	<b>408</b>

## ANGOLO CIECO | *BLIND CORNER*

- Il montante per angolo collega due librerie di serie in maniera tale da creare una struttura con angolo cieco.
- The corner post connects two standard bookcases to create a structure with a blind corner.

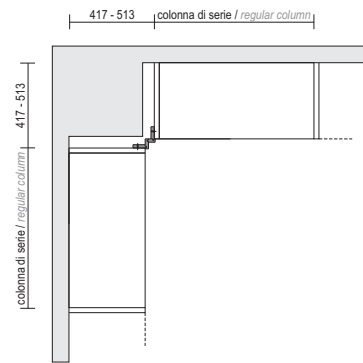
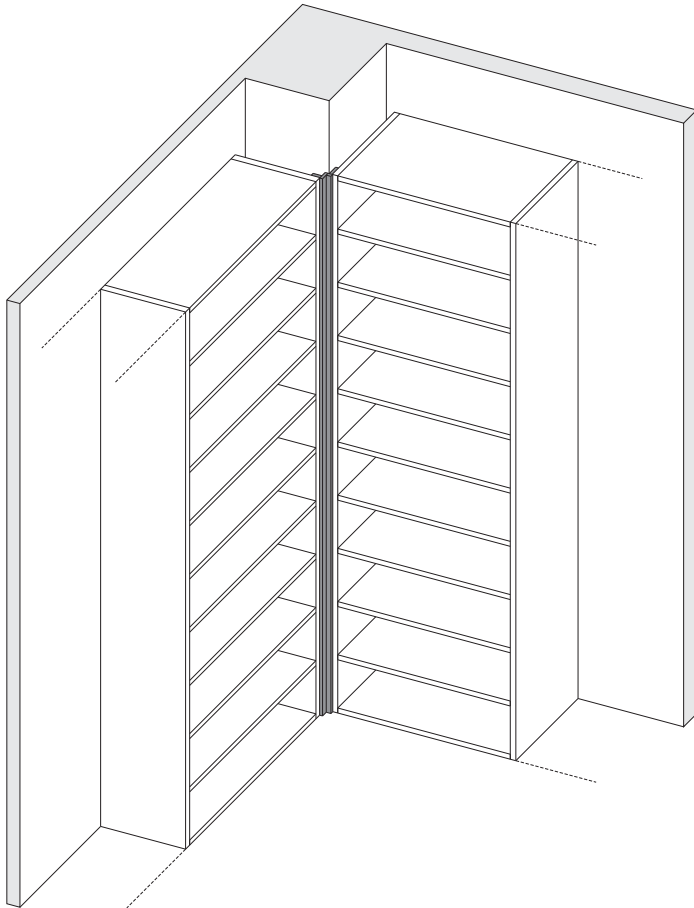

## MONTANTE PER ANGOLO CIECO | *CORNER POST FOR BLIND CORNERS*

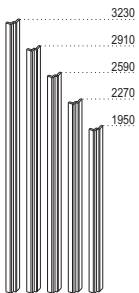
	codice code	lacc. opaco matt lacq.	essenza cat. 1 wood cat. 1	essenza cat. 2 wood cat. 2	rovere lacc. matt lacq. oak	lacc. lucido glossy lacq.	materico rovere termo.		
						superfici UP UP surface	heat-treat. oak textured f.		
Montante di collegamento per angolo cieco Connection post for blind corners									
	VOL.m <sup>3</sup> Kg								
	0,058 4,8	H. 1950	SP1X20005	<b>206</b>	<b>242</b>	<b>279</b>	<b>286</b>	<b>253</b>	<b>165</b>
	0,067 5,6	H. 2270	SP1X20006	<b>229</b>	<b>267</b>	<b>308</b>	<b>315</b>	<b>288</b>	<b>181</b>
	0,076 6,3	H. 2590	SP1X20007	<b>251</b>	<b>291</b>	<b>335</b>	<b>343</b>	<b>319</b>	<b>195</b>
	0,085 7	H. 2910	SP1X20008	<b>276</b>	<b>316</b>	<b>363</b>	<b>372</b>	<b>350</b>	<b>211</b>
	0,095 8	H. 3230	SP1X20009	<b>300</b>	<b>342</b>	<b>394</b>	<b>403</b>	<b>382</b>	<b>226</b>

- Non è possibile inserire ante o cassetti nell'angolo a giorno. La colonna per angolo a giorno è già compresa di spalla.
- È possibile inserire una o più schiene visto che i vani dell'angolo a giorno sono quelli di serie, in questo caso però si dovranno utilizzare i ripiani su schiena (per i prezzi e i codici vedere a pag. 141).
- It is not possible to include doors or drawers in the open corner. The open corner column is already furnished with a structural side panel.
- It can be equipped with one or more back panels, since its compartments are standard ones; however in this case the shelves for back shall be used. (for the prices and codes, see page 141).

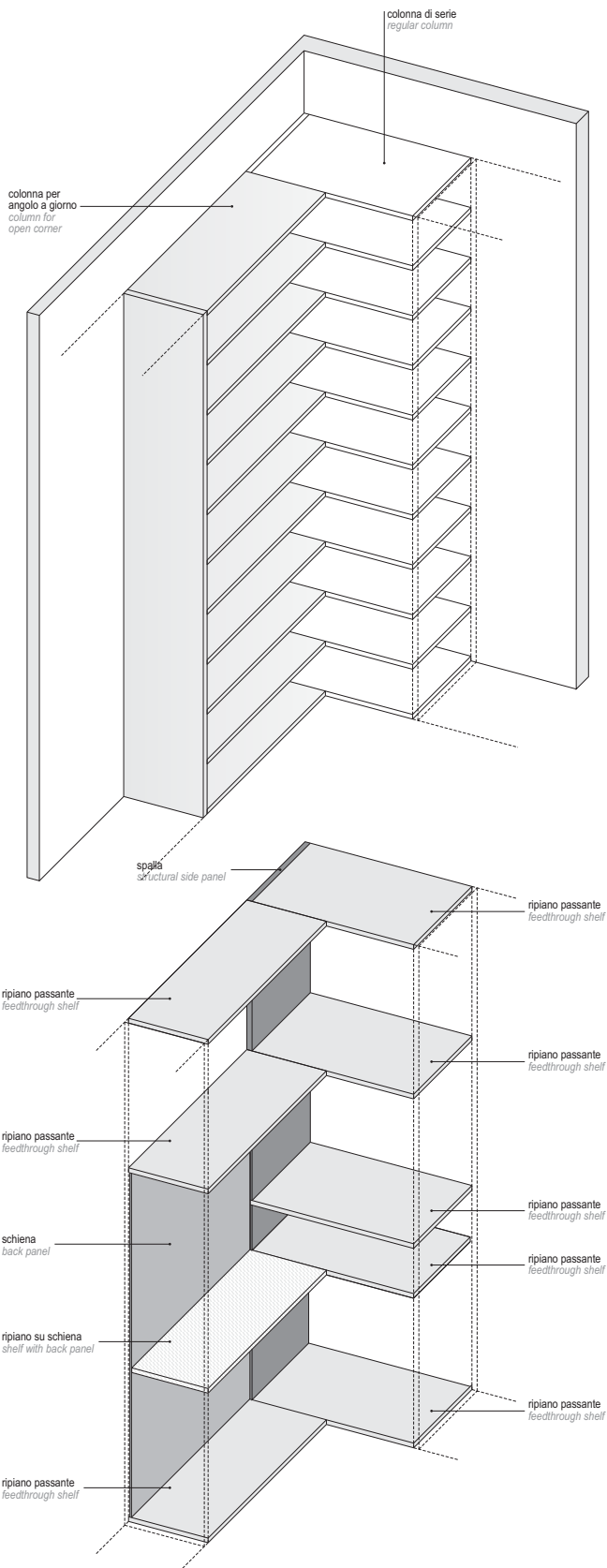

Esempio angolo sx  
Lh corner example

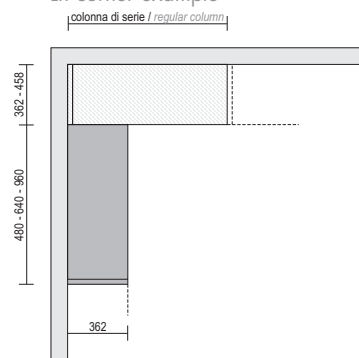

Esempio angolo dx  
Rh corner example

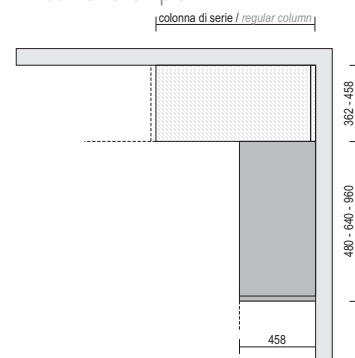

- Da specificare nell'ordine se angolo dx o sx - Se non indicato diversamente nell'ordine l'angolo a giorno è sempre senza schiene  
 - To be specified in order if rh or lh corner - Unless otherwise specified in the order, the open corner will always be without backs

Colonna per angolo a giorno L. 480  
 Open corner column L. 480

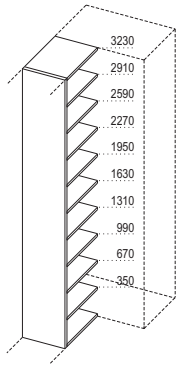

nel disegno angolo sx  
 in the drawing, lh corner

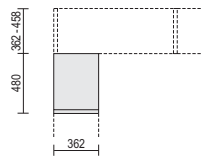

	codice code	lacc. opaco matt lacq.	essenza cat. 1 wood cat. 1	essenza cat. 2 wood cat. 2	rovere lacc. matt lacq. oak	lacc. lucido glossy lacq.	materico rovere termo. heat-treat. oak textured f.
H. 350	SP1S06320	179	262	317	334	243	148
H. 670	SP1S06321	264	384	465	492	363	213
H. 990	SP1S06322	344	506	612	650	482	273
H. 1310	SP1S06323	426	627	758	807	593	334
H. 1630	SP1S06324	508	747	904	962	721	395
H. 1950	SP1S06325	588	867	1.049	1.118	841	456
H. 2270	SP1S06326	671	997	1.206	1.286	959	516
H. 2590	SP1S06327	753	1.119	1.354	1.443	1.080	576
H. 2910	SP1S06328	835	1.243	1.503	1.603	1.200	640
H. 3230	SP1S06329	919	1.364	1.650	1.760	1.318	704

Colonna per angolo a giorno L. 640  
 Open corner column L. 640

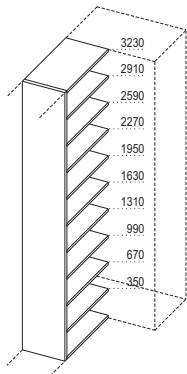

nel disegno angolo sx  
 in the drawing, lh corner

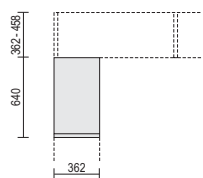

H. 350	SP1S06330	197	290	349	372	273	158
H. 670	SP1S06331	291	426	513	549	408	228
H. 990	SP1S06332	380	562	676	726	542	293
H. 1310	SP1S06333	471	697	838	902	668	359
H. 1630	SP1S06334	562	831	1.000	1.076	811	425
H. 1950	SP1S06335	651	965	1.161	1.251	946	491
H. 2270	SP1S06336	743	1.109	1.334	1.438	1.079	556
H. 2590	SP1S06337	834	1.245	1.498	1.614	1.215	621
H. 2910	SP1S06338	925	1.383	1.663	1.793	1.350	690
H. 3230	SP1S06339	1.018	1.518	1.826	1.969	1.483	759

Colonna per angolo a giorno L. 960  
 Open corner column L. 960

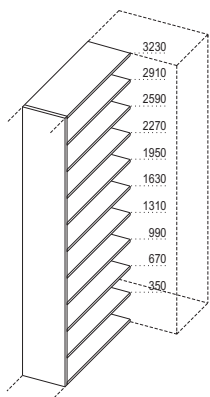

nel disegno angolo sx  
 in the drawing, lh corner

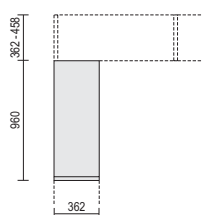

H. 350	SP1S06350	233	350	421	452	337	174
H. 670	SP1S06351	345	516	621	669	504	252
H. 990	SP1S06352	452	682	820	886	670	325
H. 1310	SP1S06353	561	847	1.018	1.102	828	399
H. 1630	SP1S06354	670	1.011	1.216	1.316	1.003	473
H. 1950	SP1S06355	777	1.175	1.413	1.531	1.170	547
H. 2270	SP1S06356	887	1.349	1.622	1.758	1.335	620
H. 2590	SP1S06357	996	1.515	1.822	1.974	1.503	693
H. 2910	SP1S06358	1.105	1.683	2.023	2.193	1.670	770
H. 3230	SP1S06359	1.216	1.848	2.222	2.409	1.835	847



- Da specificare nell'ordine se angolo dx o sx - Se non indicato diversamente nell'ordine l'angolo a giorno è sempre senza schiene  
 - To be specified in order if rh or lh corner - Unless otherwise specified in the order, the open corner will always be without backs

Colonna per angolo a giorno L. 480  
 Open corner column L. 480

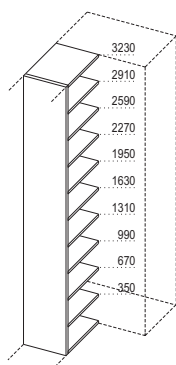

nel disegno angolo sx  
 in the drawing, lh corner

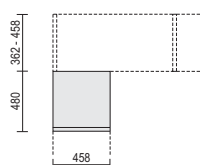

	codice code	lacc. opaco matt lacq.	essenza cat. 1 wood cat. 1	essenza cat. 2 wood cat. 2	rovere lacc. matt lacq. oak	lacc. lucido glossy lacq.	materico rovere termo. heat-treat. oak
H. 350	SP1S06420	192	291	352	374	276	157
H. 670	SP1S06421	283	428	518	554	417	225
H. 990	SP1S06422	373	562	679	729	555	292
H. 1310	SP1S06423	461	698	843	906	692	356
H. 1630	SP1S06424	547	836	1.011	1.089	830	417
H. 1950	SP1S06425	637	973	1.176	1.267	968	485
H. 2270	SP1S06426	726	1.118	1.351	1.455	1.108	548
H. 2590	SP1S06427	816	1.256	1.519	1.636	1.247	613
H. 2910	SP1S06428	904	1.394	1.685	1.816	1.388	680
H. 3230	SP1S06429	994	1.531	1.851	1.995	1.526	747

Colonna per angolo a giorno L. 640  
 Open corner column L. 640

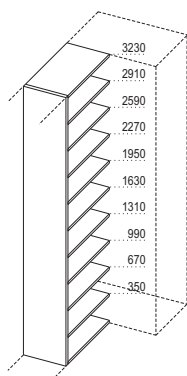

nel disegno angolo sx  
 in the drawing, lh corner

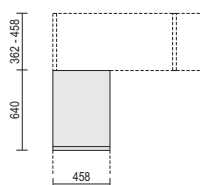

	codice code	lacc. opaco matt lacq.	essenza cat. 1 wood cat. 1	essenza cat. 2 wood cat. 2	rovere lacc. matt lacq. oak	lacc. lucido glossy lacq.	materico rovere termo. heat-treat. oak
H. 350	SP1S06430	210	321	386	414	310	169
H. 670	SP1S06431	310	473	569	614	468	243
H. 990	SP1S06432	409	622	747	809	623	316
H. 1310	SP1S06433	506	773	928	1.006	777	386
H. 1630	SP1S06434	601	926	1.113	1.209	932	453
H. 1950	SP1S06435	700	1.078	1.295	1.407	1.087	527
H. 2270	SP1S06436	798	1.238	1.487	1.615	1.244	596
H. 2590	SP1S06437	897	1.391	1.672	1.816	1.400	667
H. 2910	SP1S06438	994	1.544	1.855	2.016	1.558	740
H. 3230	SP1S06439	1.093	1.696	2.038	2.215	1.713	813

Colonna per angolo a giorno L. 960  
 Open corner column L. 960

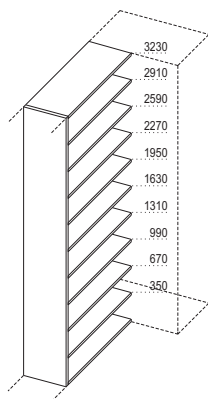

nel disegno angolo sx  
 in the drawing, lh corner

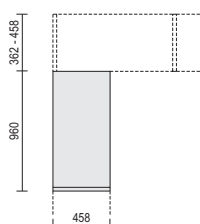

	codice code	lacc. opaco matt lacq.	essenza cat. 1 wood cat. 1	essenza cat. 2 wood cat. 2	rovere lacc. matt lacq. oak	lacc. lucido glossy lacq.	materico rovere termo. heat-treat. oak
H. 350	SP1S06450	260	399	482	520	386	193
H. 670	SP1S06451	385	590	713	773	582	279
H. 990	SP1S06452	509	778	939	1.021	775	364
H. 1310	SP1S06453	631	968	1.168	1.271	967	446
H. 1630	SP1S06454	751	1.160	1.401	1.527	1.160	525
H. 1950	SP1S06455	875	1.351	1.631	1.778	1.353	611
H. 2270	SP1S06456	998	1.550	1.871	2.039	1.548	692
H. 2590	SP1S06457	1.122	1.742	2.104	2.293	1.742	775
H. 2910	SP1S06458	1.244	1.934	2.335	2.546	1.938	860
H. 3230	SP1S06459	1.368	2.125	2.566	2.798	2.131	945

## ESEMPIO DI UTILIZZO DELLA SCALA | EXAMPLE OF LADDER USE

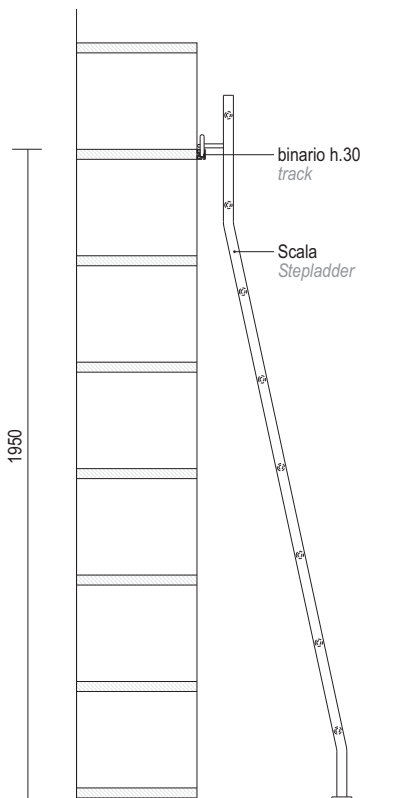

- La scala scorre su un binario in alluminio applicato ad altezza 1950 da terra.
- La misura massima del binario è di L. 6080.
- The ladder slides along an aluminium track which is secured at a height of 1950 mm from the ground.
- The maximum length of the track is L. 6080.

## SISTEMA CON SCALA SCORREVOLE | SLIDING LADDER SYSTEM

		codice code	alluminio aluminium	brown brown
<p>Scala Ladder</p> <p>VOL.m<sup>3</sup> Kg 0,100 6</p>		SP1X19313	<b>678</b>	<b>699</b>
<p>Binario H. 30 Track</p> <p>VOL.m<sup>3</sup> Kg 0,0007 0,7</p> <p>al ml. / per mtl.</p>		SP1X15413	<b>35</b>	<b>44</b>

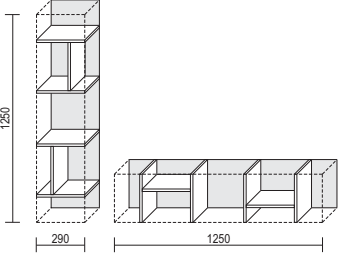
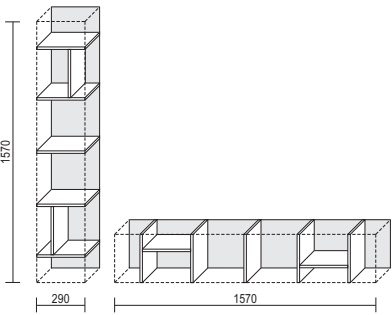
- Elementi a giorno con schiena della stessa finitura della struttura Open elements with a back panel in the same finish as the structure	codice code	lacc. opaco matt lacq.	essenza cat. 1 wood cat. 1	essenza cat. 2 wood cat. 2	rovere lacc. matt lacq. oak	lacc. lucido glossy lacq.	materico rovere termo.			
						superfici UP UP surface	heat-treat. oak textured f.			
<p>Elemento a giorno per vano da 930 Open element for compartment size 930</p> 										
		VOLm <sup>3</sup> Kg								
		0,025 7,8	P.   D. 362	SP1E01315	<b>224</b>	<b>365</b>	<b>435</b>	<b>460</b>	<b>305</b>	<b>183</b>
		0,025 9,3	P.   D. 458	SP1E01415	<b>239</b>	<b>385</b>	<b>460</b>	<b>495</b>	<b>340</b>	<b>198</b>
<p>Elemento a giorno per vano da 1250 Open element for compartment size 1250</p> 										
		VOLm <sup>3</sup> Kg								
		0,034 9,5	P.   D. 362	SP1E01316	<b>271</b>	<b>444</b>	<b>529</b>	<b>560</b>	<b>370</b>	<b>221</b>
		0,034 11,3	P.   D. 458	SP1E01416	<b>289</b>	<b>468</b>	<b>559</b>	<b>602</b>	<b>412</b>	<b>239</b>
<p>Elemento a giorno per vano da 1570 Open element for compartment size 1570</p> 										
		VOLm <sup>3</sup> Kg								
		0,042 11,3	P.   D. 362	SP1E01317	<b>318</b>	<b>517</b>	<b>616</b>	<b>652</b>	<b>435</b>	<b>255</b>
		0,042 13,4	P.   D. 458	SP1E01417	<b>339</b>	<b>545</b>	<b>651</b>	<b>701</b>	<b>484</b>	<b>276</b>

ESEMPIO DI UTILIZZO | EXAMPLE OF USE

- L'elemento a giorno in metallo non ha la schiena.
- Nel caso si inserisca nel vano una schiena di serie, l'elemento sporge di ulteriori 20 mm.
- The metal open element has no back.
- If a standard back is inserted into the compartment, the element juts out an extra 20 mm.

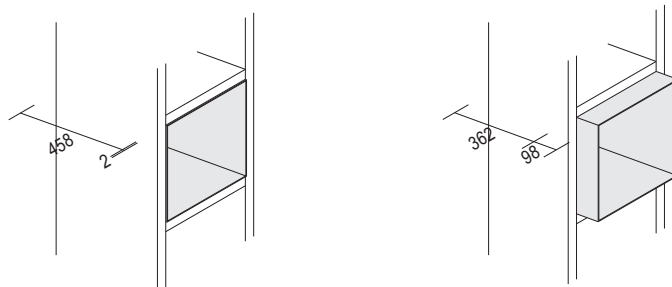

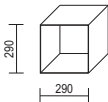
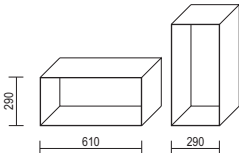
		codice code	lacc. opaco matt lacq.
<p>Elemento a giorno in metallo Metal open element</p> 	<p>VOL.m<sup>3</sup> Kg 0,040 6</p>	SP1X10422	<b>184</b>
<p>Elemento a giorno in metallo Metal open element</p> 	<p>VOL.m<sup>3</sup> Kg 0,080 12</p>	SP1X10462	<b>235</b>

- Contenitori sporgenti orizzontali o verticali da inserire all'interno della struttura Speed P. 362.  
 - L'elemento dovrà essere completato con l'inserimento di ante a ribalta, battenti, ripiani legno o vetro.  
 (Non è possibile realizzare elementi a giorno) Le finiture interne degli elementi sono: materico effetto essenza o laccato opaco in tinta per gli impiallacciati, sempre laccati opachi per laccati opachi, lucidi e superfici UP.  
 - Horizontal or vertical jutting storage units to be inserted inside Speed structure d. 362  
 - The element should always be completed with flap or hinged doors, and wooden or glass shelves.  
 (Open elements cannot be produced) The interior finishes of the elements are as follows: wood effect or matt lacquer for veneers and matt or gloss lacquer for matt, gloss and UP surfaces.

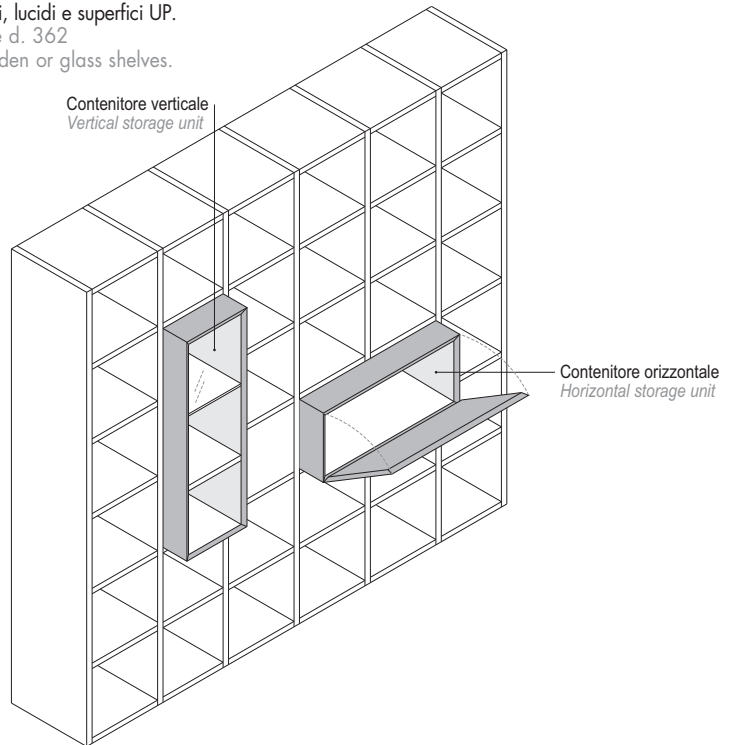
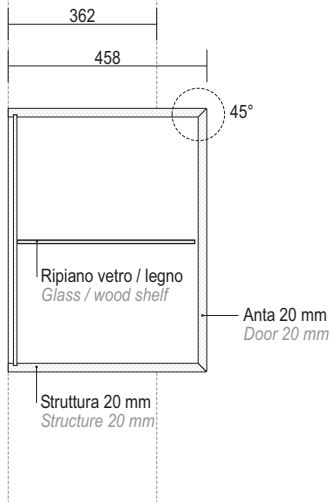

Il prezzo totale è dato dalla somma di SCOCCA VUOTA (1) + FRONTALI (2) + RIPIANO (3)  
 The total price is given by the sum of the EMPTY BODY (1) + FRONTS (2) + SHELF (3)

codice code	lacc. opaco matt lacq.	essenza cat. 1 wood cat. 1	essenza cat. 2 wood cat. 2	rovere lacc. matt lacq. oak	lacc. lucido glossy lacq. superfici UP UP surface
-------------	------------------------	----------------------------	----------------------------	-----------------------------	---

(1)	Contenitori verticali Vertical storage unit	VOL.m <sup>3</sup>	Kg	L. 289						
					0,106	12	H. 609	SP1Q01423	312	402
		0,158	17	H. 929	SP1Q01424	353	464	522	544	431
		0,210	21	H. 1249	SP1Q01425	400	538	604	631	498
				L. 449						
		0,157	15	H. 609	SP1Q01443	321	413	466	484	382
		0,235	19	H. 929	SP1Q01444	364	481	540	565	444
		0,313	24	H. 1249	SP1Q01445	416	556	624	654	515
				L. 609						
		0,209	17	H. 609	SP1Q01453	363	478	540	562	442
	Contenitori orizzontali Horizontal storage unit									
		VOL.m <sup>3</sup>	Kg							
		0,106	12	L. 609	SP1Q02451	312	402	450	463	372
		0,158	17	L. 929	SP1Q02461	353	464	522	544	431
		0,210	21	L. 1249	SP1Q02471	400	538	604	626	498

SCOCHE VUOTE | EMPTY BODIES

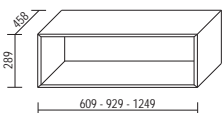
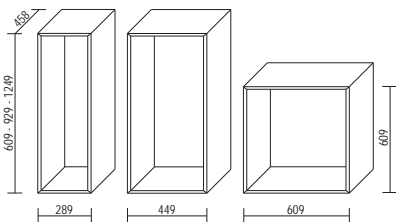

Il prezzo totale è dato dalla somma di SCOCCA VUOTA (1) + FRONTALI (2) + RIPIANO (3)  
 The total price is given by the sum of the EMPTY BODY (1) + FRONTS (2) + SHELF (3)

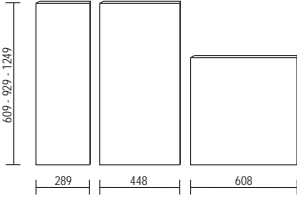
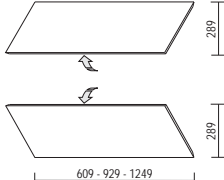
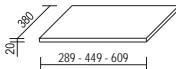
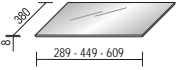
		codice code	lacc. opaco matt lacq.	essenza cat. 1 wood cat. 1	essenza cat. 2 wood cat. 2	rovere lacc. matt lacq. oak	lacc. lucido glossy lacq.		
							superfici UP UP surface		
FRONTALI   FRONTS	(2) Anta   Doors specificare nell'ordine se apertura dx o sx in the order, specify if the opening is rh or lh  Kg L. 289 2,5 3,7 4,9  								
		H. 609	SP1A45113	148	194	218	225	159	
		H. 929	SP1A45114	189	241	273	283	205	
		H. 1249	SP1A45115	232	288	327	341	249	
		L. 449							
		H. 609	SP1A45123	166	218	245	255	179	
		H. 929	SP1A45124	212	272	307	323	232	
		H. 1249	SP1A45125	260	322	368	389	279	
	L. 609								
	H. 609	SP1A45163	197	246	279	293	213		
	FRONTALI   FRONTS	Ribalta   Flap-door specificare nell'ordine il senso di apertura specify the opening direction in the order  Kg L. 609 2,5 3,7 4,9  							
			L. 609	SP1A46162	167	220	247	254	181
			L. 929	SP1A46142	214	273	304	315	232
L. 1249			SP1A46152	262	326	371	385	281	
RIPIANI   SHELVES	(3) Ripiano legno Wooden shelf  Kg L. 289 0,006 L. 449 0,009 L. 609 0,012 								
		L. 289	SP1R45422	33	26				
		L. 449	SP1R45442	39	29				
		L. 609	SP1R45452	46	33				
	RIPIANI   SHELVES	Ripiano vetro Glass shelf  Kg L. 289 0,005 L. 449 0,007 L. 609 0,010 							

N.B: Si sconsiglia l'abbinamento tra melaminico rovere termotrattato ed essenza rovere termotrattato | Matching melamine heat-treated oak and wood veneer heat-treated oak is not recommended.

- Il piano sporgente deve essere necessariamente supportato dalle divisioni a terra.  
 - The protruding bench must be supported by free-standing partitions.

	codice code	lacc. opaco matt lacq.	essenza cat. 1 wood cat. 1	essenza cat. 2 wood cat. 2	rovere lacc. matt lacq. oak	lacc. lucido glossy lacq.	materico rovere termo. heat-treat. oak
						superfici UP UP surface	heat-treat. oak textured f.

Piano sporgente  
Protruding bench

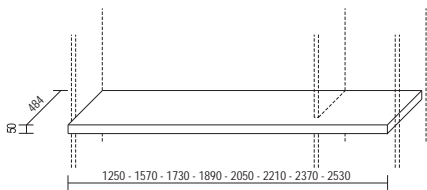

VOLm³ Kg P. | D. 484

0,061	19,5	L. 1250	SP1P104H0	166	207	249	273	228	128
0,076	24,5	L. 1570	SP1P104K0	200	238	286	315	285	155
0,083	27	L. 1730	SP1P104L0	220	258	309	342	309	170
0,091	29	L. 1890	SP1P104M0	238	276	331	367	334	184
0,099	31,5	L. 2050	SP1P104O0	254	294	354	391	361	196
0,106	34	L. 2210	SP1P104P0	270	313	375	416	387	209
0,114	36,5	L. 2370	SP1P104Q0	290	331	398	442	412	224
0,121	39	L. 2530	SP1P104R0	308	348	418	465	436	238

Divisione a terra per piano sporgente  
Free-standing partition for protruding bench

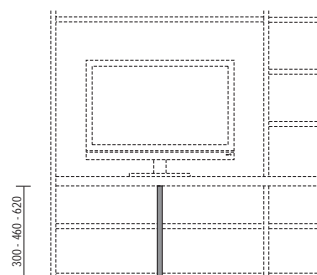

VOLm³ Kg P. | D. 362

0,010	2,5	H. 300	SP1S3E31A	49	80	97	102	69	42
0,014	3,5	H. 460	SP1S3E31B	60	97	116	124	85	48
0,019	5	H. 620	SP1S3E31D	69	112	134	144	102	54

VOLm³ Kg P. | D. 458

0,012	3	H. 300	SP1S3E41A	54	90	108	115	78	47
0,017	4,5	H. 460	SP1S3E41B	66	108	130	140	100	53
0,023	6	H. 620	SP1S3E41D	76	127	153	165	120	61

# PIANO SCRITTOIO | *DESK TOP*

SP. | TH. 50

N.B: Si sconsiglia l'abbinamento tra melaminico rovere termotrattato ed essenza rovere termotrattato | Matching melamine heat-treated oak and wood veneer heat-treated oak is not recommended.

- Il piano scrittoio va posizionato sempre tra due spalle siano esse a terra, pensili o sovrapposte; è rinforzato da un traverso inferiore.  
 - The desk top must always be positioned between two side panels, whether they are free-standing, wall units or superimposed. It is reinforced by a lower crossbeam.

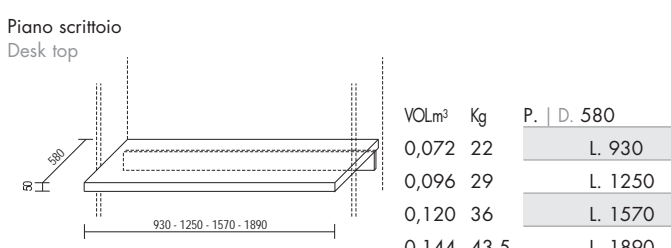
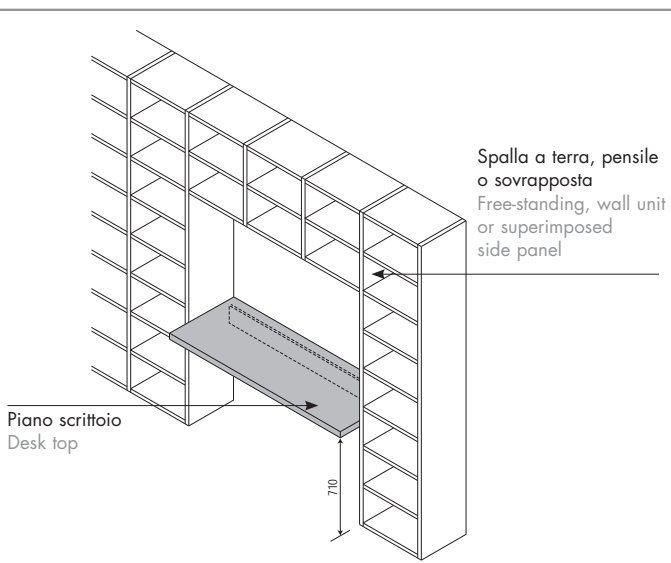

		VOLm <sup>3</sup> Kg		P.   D. 580		codice	lacc. opaco	essenza cat. 1	essenza cat. 2	rovere lacc.	lacc. lucido	materico
							matt lacq.	wood cat. 1	wood cat. 2	matt lacq. oak	glossy lacq.	rovere termo.
											superfici UP	heat-treat. oak
											UP surface	textured f.
		0,072	22	L. 930	SP1P205FO	<b>241</b>	<b>304</b>	<b>366</b>	<b>386</b>	<b>310</b>	<b>186</b>	
		0,096	29	L. 1250	SP1P205HO	<b>263</b>	<b>344</b>	<b>413</b>	<b>441</b>	<b>345</b>	<b>202</b>	
		0,120	36	L. 1570	SP1P205KO	<b>312</b>	<b>400</b>	<b>480</b>	<b>515</b>	<b>421</b>	<b>240</b>	
		0,144	43,5	L. 1890	SP1P205MO	<b>368</b>	<b>467</b>	<b>561</b>	<b>603</b>	<b>494</b>	<b>283</b>	

# ELEMENTO CON 3 CASSETTINI | *ELEMENT WITH 3 DRAWERS*

L. 449 H. 449

- L'elemento con cassettini va posizionato all'interno di vani Speed L.450 H. 450 oppure da solo in appoggio a home office, piani oppure basi. Disponibile in laccato opaco, materico effetto pelle o materico rovere termotrattato.  
 - The drawer unit must be positioned inside the Speed 450 x 450 mm (L x H) compartments, or independently-supported by home offices, benches or base units. Available in a matt lacquer, leather-effect or heat-treated oak textured finish.

Elemento con 3 cassettini  
 Element with 3 little drawers

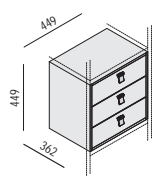

		VOLm <sup>3</sup> Kg		L. 449 H. 449		codice	lacc. opaco	materico
							matt lacq.	textured finish
		0,096	18,5	L. 449 H. 449	SP1E02344	<b>480</b>	<b>409</b>	

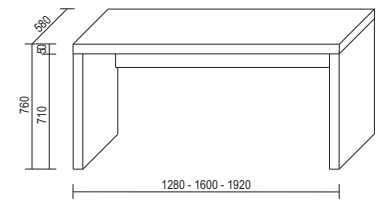
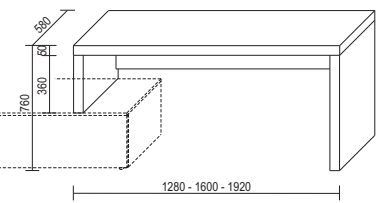
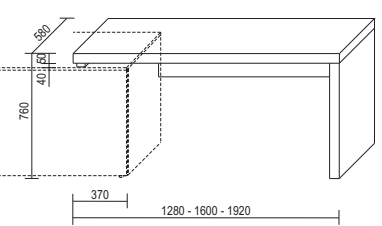

N.B: Si sconsiglia l'abbinamento tra melaminico rovere termotrattato ed essenza rovere termotrattato | Matching melamine heat-treated oak and wood veneer heat-treated oak is not recommended.

SCRIVANIA   WRITING DESK	codice code	lacc. opaco matt lacq.	essenza cat. 1 wood cat. 1	essenza cat. 2 wood cat. 2	rovere lacc. matt lacq. oak	lacc. lucido glossy lacq.	materico rovere termo. heat-treat. oak textured f.	
						superfici UP UP surface		
<p>SCRIVANIA   WRITING DESK</p>  <p>VOLm³ Kg</p>	L. 1280	SP1U015H5	485	660	793	842	663	360
	L. 1600	SP1U015K5	559	761	913	968	756	414
	L. 1920	SP1U015M5	641	872	1.047	1.111	852	476
<p>SCRIVANIA   WRITING DESK in appoggio su basi H. 320 P. 580 specificare nell'ordine se dx o sx supported on bases H. 320 D. 580 specify if rh or lh in the order</p> <p>a disegno dx in the drawing, rh</p>  <p>VOLm³ Kg</p>	L. 1280	SP1U025H5	447	612	735	779	602	331
	L. 1600	SP1U025K5	521	710	853	904	695	387
	L. 1920	SP1U025M5	603	821	985	1.045	789	448
<p>SCRIVANIA   WRITING DESK in appoggio su basi H. 640 P. 580 specificare nell'ordine se dx o sx supported on bases H. 640 D. 580 specify if rh or lh in the order</p> <p>a disegno dx in the drawing, rh</p>  <p>VOLm³ Kg</p>	L. 1280	SP1U035H5	424	577	693	735	562	315
	L. 1600	SP1U035K5	498	679	815	864	655	370
	L. 1920	SP1U035M5	580	789	947	1.004	751	430

N.B: Si sconsiglia l'abbinamento tra melaminico rovere termotrattato ed essenza rovere termotrattato | Matching melamine heat-treated oak and wood veneer heat-treated oak is not recommended.

- Sistema home office composto da piano sospeso o con gambe di supporto (dotato di staffe annegate all'interno del piano da fissare al muro), disponibile anche con schienale e luce led optional.  
 - The home office system consists of a top which can be suspended or secured on support feet (supplied with brackets that have been built into the top in order to mount to the wall). Also available with a back panel and optional LED light.

	codice code	lacc. opaco matt lacq.	essenza cat. 1 wood cat. 1	essenza cat. 2 wood cat. 2	rovere lacc. matt lacq. oak	lacc. lucido glossy lacq.	materico rovere termo. heat-treat. oak textured f.
						superfici UP UP surface	

PIANO sp. 50 mm | TOP th. 50 mm  
 Da utilizzare sospeso oppure sostenuto da 1 o più gambe di supporto: gambe obbligatorie nella P.580 oppure nel caso non sia possibile il fissaggio di una o più staffe a parete  
 Can be suspended or supported by 1 or more support legs: the 580 mm-deep legs must be used if it cannot be fixed to one or more wall brackets

VOLm³	Kg	P.   D. 484							
0,053	18,5	L. 960	SP1P124F2	132	162	200	225	184	93
0,070	25	L. 1280	SP1P124H2	166	207	249	273	228	117
0,088	31	L. 1600	SP1P124K2	200	238	286	316	285	142
0,103	36	L. 1920	SP1P124M2	238	276	331	367	334	168

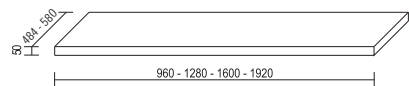

VOLm³	Kg	P.   D. 580							
0,062	21	L. 960	SP1P125F2	142	173	214	241	196	101
0,083	29	L. 1280	SP1P125H2	180	211	261	297	247	127
0,103	36	L. 1600	SP1P125K2	219	261	323	369	302	155
0,120	42	L. 1920	SP1P125M2	259	308	381	435	357	183

SCHIENALE | BACK PANEL  
 Disponibile con luce led superiore optional (il sistema di accensione completo di alimentatore, deve essere collegato ad un interruttore della rete elettrica della stanza, luce calda 3000°K).  
 Available with an optional LED light on the bench (the switch-on system with a power supply must be connected to a mains switch in the room. 3000K warm light).

VOLm³	Kg	H. 240							
0,018	4	L. 960	SP1S10150	75	79	92	97	91	54
0,024	5,5	L. 1280	SP1S10160	100	105	123	128	121	73
0,030	7	L. 1600	SP1S10170	125	131	153	160	152	91
0,036	8,2	L. 1920	SP1S10180	150	158	183	192	182	108

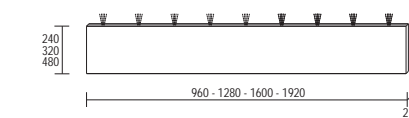

VOLm³	Kg	H. 320							
0,023	5,5	L. 960	SP1S10151	100	105	123	128	121	73
0,031	7	L. 1280	SP1S10161	133	141	162	170	161	98
0,038	8,7	L. 1600	SP1S10171	166	175	204	213	201	120
0,046	10,5	L. 1920	SP1S10181	199	210	243	255	242	145

maggiorazione LED surcharge LED light  
**€ 147**  
**€ 164**  
**€ 182**  
**€ 213**

VOLm³	Kg	H. 480							
0,034	8	L. 960	SP1S10152	150	158	183	192	182	108
0,045	10,5	L. 1280	SP1S10162	199	210	243	255	242	145
0,055	13	L. 1600	SP1S10172	248	262	305	319	302	180
0,066	15,5	L. 1920	SP1S10182	297	315	366	382	362	216

GAMBA DI SUPPORTO SUPPORT LEG  
 In metallo finitura brown, titanio, bianco o ottone  
 Metal leg available in a brown, titanium, white or brass finish

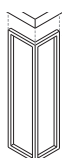

VOLm³	Kg	codice code	metallo metal
0,015	2	H. 710 SP1XP0172	147

# CASSETTIERE PER SCRIVANIE E PIANI | DRAWER UNITS FOR DESKS AND BENCHES P. | D. 484

N.B: Si sconsiglia l'abbinamento tra melaminico rovere termotrattato ed essenza rovere termotrattato | Matching melamine heat-treated oak and wood veneer heat-treated oak is not recommended.

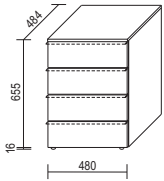
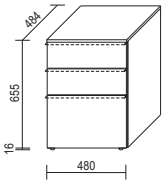
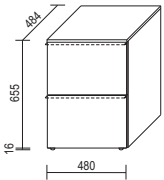
	codice code	lacc. opaco matt lacq.	essenza cat. 1 wood cat. 1	essenza cat. 2 wood cat. 2	rovere lacc. matt lacq. oak	lacc. lucido glossy lacq.	superfici UP UP surface																																
<p>CASSETTIERA 4 cassetti   DRAWER UNIT 4 drawers Disponibile a richiesta con 4 ruote piroettanti H.45 Available on demand with 4 swivelling wheels H. 45</p>  <p>VOLm³ Kg 0,184 34 0,004 0,4</p> <table border="1"> <tr> <td>Cassettiera   Drawer unit</td> <td>SP1UA1423</td> <td><b>574</b></td> <td><b>636</b></td> <td><b>713</b></td> <td><b>749</b></td> <td><b>662</b></td> <td></td> </tr> <tr> <td>Maggiorazione 4 ruote 4-wheel surcharge</td> <td>SPX4011</td> <td><b>27</b></td> <td></td> <td></td> <td></td> <td></td> <td></td> </tr> <tr> <td>Maniglia Slim   Slim handle</td> <td></td> <td><b>24</b></td> <td></td> <td></td> <td></td> <td></td> <td></td> </tr> <tr> <td>Tirador gola   Groove handle</td> <td></td> <td><b>128</b></td> <td></td> <td></td> <td></td> <td></td> <td></td> </tr> </table>	Cassettiera   Drawer unit	SP1UA1423	<b>574</b>	<b>636</b>	<b>713</b>	<b>749</b>	<b>662</b>		Maggiorazione 4 ruote 4-wheel surcharge	SPX4011	<b>27</b>						Maniglia Slim   Slim handle		<b>24</b>						Tirador gola   Groove handle		<b>128</b>												
Cassettiera   Drawer unit	SP1UA1423	<b>574</b>	<b>636</b>	<b>713</b>	<b>749</b>	<b>662</b>																																	
Maggiorazione 4 ruote 4-wheel surcharge	SPX4011	<b>27</b>																																					
Maniglia Slim   Slim handle		<b>24</b>																																					
Tirador gola   Groove handle		<b>128</b>																																					
<p>CASSETTIERA 2 cassetti e 1 cestone   DRAWER UNIT 2 drawers and 1 deep drawer Disponibile a richiesta con 4 ruote piroettanti H.45 Available on demand with 4 swivelling wheels H. 45</p>  <p>VOLm³ Kg 0,184 32 0,004 0,4</p> <table border="1"> <tr> <td>Cassettiera   Drawer unit</td> <td>SP1UA2423</td> <td><b>507</b></td> <td><b>564</b></td> <td><b>634</b></td> <td><b>666</b></td> <td><b>597</b></td> <td></td> </tr> <tr> <td>Maggiorazione 4 ruote 4-wheel surcharge</td> <td>SPX4011</td> <td><b>27</b></td> <td></td> <td></td> <td></td> <td></td> <td></td> </tr> <tr> <td>Maniglia Slim   Slim handle</td> <td></td> <td><b>18</b></td> <td></td> <td></td> <td></td> <td></td> <td></td> </tr> <tr> <td>Tirador gola   Groove handle</td> <td></td> <td><b>96</b></td> <td></td> <td></td> <td></td> <td></td> <td></td> </tr> </table>	Cassettiera   Drawer unit	SP1UA2423	<b>507</b>	<b>564</b>	<b>634</b>	<b>666</b>	<b>597</b>		Maggiorazione 4 ruote 4-wheel surcharge	SPX4011	<b>27</b>						Maniglia Slim   Slim handle		<b>18</b>						Tirador gola   Groove handle		<b>96</b>												
Cassettiera   Drawer unit	SP1UA2423	<b>507</b>	<b>564</b>	<b>634</b>	<b>666</b>	<b>597</b>																																	
Maggiorazione 4 ruote 4-wheel surcharge	SPX4011	<b>27</b>																																					
Maniglia Slim   Slim handle		<b>18</b>																																					
Tirador gola   Groove handle		<b>96</b>																																					
<p>CASSETTIERA 2 cestoni   DRAWER UNIT 2 deep drawers Disponibile a richiesta con 4 ruote piroettanti H.45 Available on demand with 4 swivelling wheels H. 45</p>  <p>VOLm³ Kg 0,184 30 0,004 0,4</p> <table border="1"> <tr> <td>Cassettiera   Drawer unit</td> <td>SP1UA3423</td> <td><b>440</b></td> <td><b>492</b></td> <td><b>555</b></td> <td><b>583</b></td> <td><b>532</b></td> <td></td> </tr> <tr> <td>Maggiorazione 4 ruote 4-wheel surcharge</td> <td>SPX4011</td> <td><b>27</b></td> <td></td> <td></td> <td></td> <td></td> <td></td> </tr> <tr> <td>Maniglia Slim   Slim handle</td> <td></td> <td><b>12</b></td> <td></td> <td></td> <td></td> <td></td> <td></td> </tr> <tr> <td>Maniglia gola   Groove handle</td> <td></td> <td><b>64</b></td> <td></td> <td></td> <td></td> <td></td> <td></td> </tr> </table>	Cassettiera   Drawer unit	SP1UA3423	<b>440</b>	<b>492</b>	<b>555</b>	<b>583</b>	<b>532</b>		Maggiorazione 4 ruote 4-wheel surcharge	SPX4011	<b>27</b>						Maniglia Slim   Slim handle		<b>12</b>						Maniglia gola   Groove handle		<b>64</b>												
Cassettiera   Drawer unit	SP1UA3423	<b>440</b>	<b>492</b>	<b>555</b>	<b>583</b>	<b>532</b>																																	
Maggiorazione 4 ruote 4-wheel surcharge	SPX4011	<b>27</b>																																					
Maniglia Slim   Slim handle		<b>12</b>																																					
Maniglia gola   Groove handle		<b>64</b>																																					

DESCRIZIONE   DESCRIPTION			prezzo per elemento price for element
Riduzione spalle sp. 30 mm in Altezza o Profondità (dimensione minima in P. 170 mm) Reduction of side panels th. 30 mm in Height or Depth (minimum dimension in D. 170 mm)			52
Riduzione ripiani sp. 30 in Larghezza o Profondità (dimensione minima in P. 170 mm) Reduction of shelves th. 30 in Length or Depth (minimum dimension in D. 170 mm)			39
Riduzione ripiani vetro in Larghezza o Profondità Reduction of glass shelves in Length or Depth			64
Riduzione schiene sp. 12 mm in Larghezza o Altezza Reduction of back panels th. 12 mm in Length or Height			45
Riduzione top sp. 15 mm in Larghezza o Profondità Reduction of tops th. 15 mm in Length or Depth			52
Riduzione ribalte legno sp. 20 mm in Larghezza Reduction of flap doors th. 20 mm in Length			64
Riduzione ante battenti legno sp. 20 mm in Larghezza o Altezza Reduction of hinged doors th. 20 mm in Length or Height			64
Riduzione scrivanie in Larghezza o Profondità Reduction of desks in Length or Depth		prezzo per ogni taglio price for each cut	64
Riduzione piani sporgenti in Larghezza o Profondità Reduced Length or Depth protruding benches		prezzo per ogni taglio price for each cut	64
Riduzione piani scrittoio in Larghezza Reduced Length desk tops			113
Riduzione piani scrittoio in Profondità Reduced Depth desk tops			64
Ripiani a sbalzo fino alla larghezza massima di 1250 mm - prezzo al ml Cantilevered shelves up to a max. length of 1250 mm - price per LM		P.   D. 362 P.   D. 458	253 293
Sovrapprezzo per coppia guide ad estrazione totale Surcharge for a pair of full-extension pull-out runners		P.   D. 362 P.   D. 458	33 33
Cd. SL1X23139 larghezza max. 300, min. 30 mm lunghezza max. 3230 mm  max. width 300, min. 30 mm max. length 3230 mm	Fascia di tamponamento in lacc. opaco Infill panel in matt lacq.	prezzo al ml price per MTL	58
	Fascia di tamponamento in essenza cat. 1 Infill panel in wood finish cat. 1	prezzo al ml price per MTL	91
	Fascia di tamponamento in essenza cat. 2 Infill panel in wood finish cat. 2	prezzo al ml price per MTL	103
	Fascia di tamponamento in lacc. lucido e superfici up Infill panel in glossy lacq. and up surface	prezzo al ml price per MTL	85
Laccato a campione (comunicare codice RAL di riferimento) Lacquer as per the sample (specify reference RAL code)		maggiorazione surcharge	+ 20 %
Laccatura maniglia Slim (comunicare codice RAL di riferimento) Slim handle lacquering (specify reference RAL code)			34
Riduzione maniglia Reduction of handle			52
Elementi particolari che non si possono modificare: cassetti, ante vetro, ante scorrevoli, mediacentri, ripiani sp. 15 mm, ripiani rinforzati sp. 30 mm, elementi a giorno in legno e metallo. Inoltre non si possono fare lavorazioni in curvo. Eventuali lavorazioni, non previste nel presente listino, dovranno essere preventivamente richieste ai nostri uffici vendite. Particular elements that cannot be modified: drawers, glass doors, sliding doors, mediacenters, shelves th. 15 mm, reinforced shelves th. 30 mm, wooden open elements and metal open elements. Furthermore, machining cannot be done on curved elements. Any special working not included in this price list shall be checked beforehand with our sales office.			

SOLUZIONI SU MISURA PREVISTE | CUSTOM SOLUTIONS PROVIDED

Soluzioni bifacciali previste (lavorazioni con maggiorazione):  
 - Solo su librerie senza schiena.  
 - Ancoraggio obbligatorio a parete o a soffitto per garantire la stabilità.  
 - Previsto l'inserimento di ante battenti, scorrevoli, ribalte, cassetti e cestoni (con schiena o frontale sul retro).

Double-sided solutions are available (with a machining surcharge):  
 - On bookcases without a back panel only.  
 - Fastening to the wall or ceiling is mandatory in order to guarantee stability.  
 - Hinged doors, sliding doors, flap doors, drawers and deep drawers (with a back panel or front on the back) can be inserted.

Soluzioni bifacciali non previste:  
 - Non previsto l'inserimento di ripiani sp.15 e di elementi a giorno

Unavailable double-sided solutions:  
 - 15 mm-thick shelves and open elements cannot be inserted.



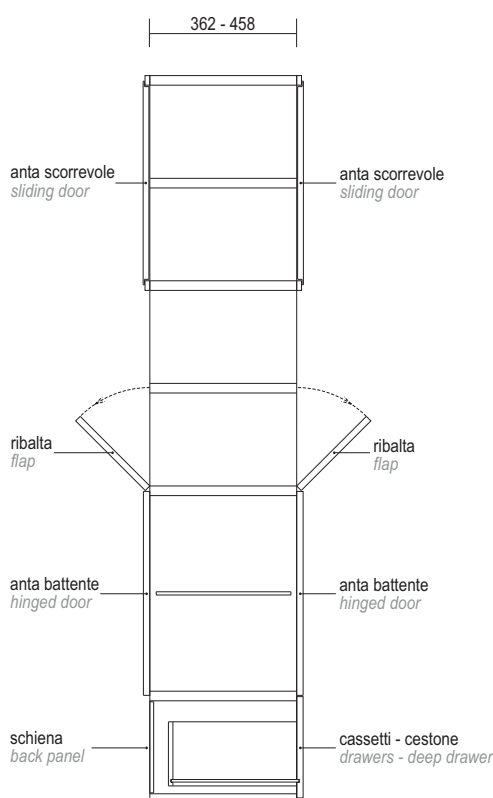

Sezione laterale | Side section



MAGGIORAZIONE da applicare ad ogni ripiano, spalla e divisione sp. 30  
 A SURCHARGE will be applied to every shelf, structural side panel and partition th. 30

prezzo / price

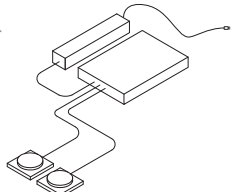
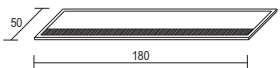
Spalla   Structural side panel	+ 30%
Divisione   Partition	+ 30%
Ripiano   Shelf	+ 30%

		codice code	prezzo price																					
<p><b>LUCI LED:</b> luce calda 3000°K. Per il calcolo corretto sommare il prezzo delle luci led nelle misure volute + il prezzo dell'alimentatore adatto. Attenzione: la gestione del posizionamento dell'alimentatore sarà a cura del cliente. Il sistema di accensione deve essere collegato ad un interruttore della rete elettrica della stanza.</p> <p><b>LED LIGHTS:</b> 3000K warm light. To work out the correct price, add the price of the LED lights in the desired sizes and the price of the suitable power supply. Please note: It is the customer's responsibility to correctly install the power pack. The switch-on system must be connected to a mains switch in the room.</p>																								
<p>Luce led incassata, completa di schermo protettivo Built-in LED light with a protective screen</p>																								
																								
<p>da posizionare su ripiani sp. 30 (esclusi ripiani supportati) To be positioned on 30 mm-thick shelves (except for reinforced shelves)</p>	<p>da posizionare su ripiani sp. 30 sopra mediacenter (esclusi ripiani supportati) To be positioned on 30 mm-thick shelves above the mediacenter (except for reinforced shelves)</p>	<p>Luce LED per vano   Unit LED light</p> <table border="1"> <tr><td>L. 290 - 3 W</td><td>SL1XL0320</td><td>94</td></tr> <tr><td>L. 450 - 5 W</td><td>SL1XL0480</td><td>103</td></tr> <tr><td>L. 610 - 7 W</td><td>SL1XL0640</td><td>110</td></tr> <tr><td>L. 930 - 10 W</td><td>SL1XL0960</td><td>126</td></tr> <tr><td>L. 1250 - 13 W</td><td>SL1XL1280</td><td>142</td></tr> <tr><td>L. 1570 - 16 W</td><td>SL1XL1600</td><td>156</td></tr> <tr><td>L. 1890 - 22 W</td><td>SL1XL1920</td><td>169</td></tr> </table>	L. 290 - 3 W	SL1XL0320	94	L. 450 - 5 W	SL1XL0480	103	L. 610 - 7 W	SL1XL0640	110	L. 930 - 10 W	SL1XL0960	126	L. 1250 - 13 W	SL1XL1280	142	L. 1570 - 16 W	SL1XL1600	156	L. 1890 - 22 W	SL1XL1920	169	
L. 290 - 3 W	SL1XL0320	94																						
L. 450 - 5 W	SL1XL0480	103																						
L. 610 - 7 W	SL1XL0640	110																						
L. 930 - 10 W	SL1XL0960	126																						
L. 1250 - 13 W	SL1XL1280	142																						
L. 1570 - 16 W	SL1XL1600	156																						
L. 1890 - 22 W	SL1XL1920	169																						
		+																						
		Alimentatore   Power supply																						
		15 W	SL1XA0480 22																					
		20 W	SL1XA0960 26																					
		30 W	SL1XA1600 45																					
<p><b>KIT RICARICA WIRELESS INVISIBILE</b> adatto per qualsiasi smartphone dotato di ricevitore o con opportuna cover (per l'elenco completo degli smartphone compatibili: <a href="http://www.qinside.biz/en/support/qi-enabled-phones-2017">http://www.qinside.biz/en/support/qi-enabled-phones-2017</a>)</p> <p><b>INVISIBLE WIRELESS CHARGING KIT</b> suitable for any smartphone with a receiver or suitable cover (for the full list of compatible smartphones, visit: <a href="http://www.qinside.biz/en/support/qi-enabled-phones-2017">http://www.qinside.biz/en/support/qi-enabled-phones-2017</a>)</p> <p>Comprendivo di alimentatore. Posizionabile su ripiani sp. 30 (esclusi ripiani supportati) e su piani sp. 50, specificare l'esatto posizionamento e quindi verificare con i nostri uffici vendite fattibilità e prezzo.</p> <p>Il sistema di accensione deve essere collegato ad un interruttore della rete elettrica della stanza.</p> <p>Power supply included. Can be placed on 30 mm-thick shelves (excluding supported shelves) and 50 mm-thick tops. Specify the exact position and then check with our sales department for a price and to see if this is feasible.</p> <p>The switch-on system must be connected to a mains switch in the room.</p>																								
		A99020	231																					
<p><b>KIT AUDIO BLUETOOTH™ INVISIBILE</b> dispositivo audio e stereo completamente celato all'interno dei mobili governabile mediante modulo bluetooth™ completo di n. 2 altoparlanti a contatto, amplificatore e alimentatore.</p> <p><b>INVISIBLE BLUETOOTH™ AUDIO KIT</b> an audio and stereo device, completely concealed within the cabinet. Can be managed via a Bluetooth™ module and comes with 2 Bluetooth speakers, an amplifier and a power pack.</p> <p>Posizionabile su mediacenter e su schienali per TV.</p> <p>Il sistema di accensione deve essere collegato ad un interruttore della rete elettrica della stanza.</p> <p>Can be positioned on a TV mediacenter or back panel.</p> <p>The switch-on system must be connected to a mains switch in the room.</p>																								
		A99021	518																					
<p><b>Passacavi   Cable duct</b></p>																								
		<p>Bianco   White</p> <p>A99013 48</p>																						
		<p>Nero   Black</p> <p>A99012 48</p>																						
		<p>Lavorazione per passacavi Machining for cable duct</p> <p>49</p>																						
		<p>Lavorazione per passacavi su basi Machining for cable duct on bases</p> <p>84</p>																						
<p><b>Copri foro   Hole cover</b></p>																								
		<p>Grigio   Grey</p> <p>A99011 20</p>																						
		<p>Lavorazione per copriforo Machining for hole cover</p> <p>49</p>																						
		<p>Lavorazione per copriforo su basi Machining for hole cover on bases</p> <p>84</p>																						

## COLONNE A TERRA | FREE-STANDING COLUMNS

## H. 350

N.B: Si consiglia l'abbinamento tra melaminico rovere termotrattato ed essenza rovere termotrattato | Matching melamine heat-treated oak and wood veneer heat-treated oak is not recommended.

* I ripiani di lunghezza superiore a 930 devono essere necessariamente intervallati da divisioni tra ripiani o divisioni a terra. * Shelves longer than 930 mm, must be interspersed with partitions between the shelves or free-standing partitions.	codice code	lacc. opaco matt lacq.	essenza cat. 1 wood cat. 1	essenza cat. 2 wood cat. 2	rovere lacc. matt lacq. oak	lacc. lucido glossy lacq.	materico rovere termo. heat-treat. oak textured f.	
						superfici UP UP surface		
Colonna a terra - completamente schienata Free-standing column - provided with a back panel								
	<b>P.   D. 362</b>							
	L. 320	SP1C0132A	99	141	168	180	136	83
	L. 480	SP1C0134A	126	180	215	230	181	92
	L. 640	SP1C0135A	150	218	261	281	219	107
	* L. 960	SP1C0136A	200	281	335	366	302	130
	+							
	<b>Spalla   Side panel</b>	SP1S3T33A	49	74	89	94	69	44
	<b>P.   D. 458</b>							
	L. 320	SP1C0142A	105	155	186	198	150	89
	L. 480	SP1C0144A	134	196	235	256	205	98
	L. 640	SP1C0145A	162	236	283	307	249	117
	* L. 960	SP1C0146A	224	321	383	420	344	144
	+							
	<b>Spalla   Side panel</b>	SP1S3T43A	54	83	100	106	78	49

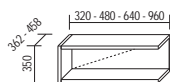

## COLONNE A TERRA | FREE-STANDING COLUMNS

## H. 510

* I ripiani di lunghezza superiore a 930 devono essere necessariamente intervallati da divisioni tra ripiani o divisioni a terra. * Shelves longer than 930 mm, must be interspersed with partitions between the shelves or free-standing partitions.	codice code	lacc. opaco matt lacq.	essenza cat. 1 wood cat. 1	essenza cat. 2 wood cat. 2	rovere lacc. matt lacq. oak	lacc. lucido glossy lacq.	materico rovere termo. heat-treat. oak textured f.	
						superfici UP UP surface		
Colonna a terra - completamente schienata Free-standing column - provided with a back panel								
	<b>P.   D. 362</b>							
	L. 320	SP1C0132C	106	148	177	190	147	86
	L. 480	SP1C0134C	136	194	231	247	194	99
	L. 640	SP1C0135C	161	231	275	296	237	111
	* L. 960	SP1C0136C	217	303	360	394	326	139
	+							
	<b>Spalla   Side panel</b>	SP1S3T33C	60	88	106	114	85	50
	<b>P.   D. 458</b>							
	L. 320	SP1C0142C	112	162	195	208	161	92
	L. 480	SP1C0144C	144	210	251	273	218	105
	L. 640	SP1C0145C	173	249	297	322	267	121
	* L. 960	SP1C0146C	241	343	408	448	368	153
	+							
	<b>Spalla   Side panel</b>	SP1S3T43C	66	99	119	129	100	57

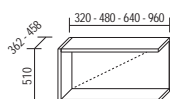

## COLONNE A TERRA | FREE-STANDING COLUMNS

H. 670

N.B: Si consiglia l'abbinamento tra melaminico rovere termotrattato ed essenza rovere termotrattato | Matching melamine heat-treated oak and wood veneer heat-treated oak is not recommended.

\* I ripiani di lunghezza superiore a 930 devono essere necessariamente intervallati da divisioni tra ripiani o divisioni a terra.  
\* Shelves longer than 930 mm, must be interspersed with partitions between the shelves or free-standing partitions.

Colonna a terra - completamente schienata  
Free-standing column - provided with a back panel

	codice code	lacc. opaco matt lacq.	essenza cat. 1 wood cat. 1	essenza cat. 2 wood cat. 2	rovere lacc. matt lacq. oak	lacc. lucido glossy lacq.	materico rovere termo. heat-treat. oak textured f.
						superfici UP UP surface	
<b>P.   D. 362</b>							
L. 320	SP1C0132D	149	216	258	277	204	122
L. 480	SP1C0134D	189	272	324	348	271	135
L. 640	SP1C0135D	225	325	389	421	332	153
* L. 960	SP1C0136D	309	428	510	560	459	191
+							
<b>Spalla   Side panel</b>	SP1S3T33D	69	102	123	132	102	57
<b>P.   D. 458</b>							
L. 320	SP1C0142D	158	234	281	300	227	131
L. 480	SP1C0144D	202	296	353	384	309	144
L. 640	SP1C0145D	245	355	425	463	376	168
* L. 960	SP1C0146D	344	484	576	636	522	212
+							
<b>Spalla   Side panel</b>	SP1S3T43D	76	116	140	152	120	63

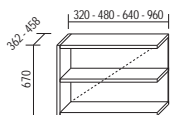

## COLONNE A TERRA | FREE-STANDING COLUMNS

H. 990

\* I ripiani di lunghezza superiore a 930 devono essere necessariamente intervallati da divisioni tra ripiani o divisioni a terra.  
\* Shelves longer than 930 mm, must be interspersed with partitions between the shelves or free-standing partitions.

Colonna a terra - completamente schienata  
Free-standing column - provided with a back panel

	codice code	lacc. opaco matt lacq.	essenza cat. 1 wood cat. 1	essenza cat. 2 wood cat. 2	rovere lacc. matt lacq. oak	lacc. lucido glossy lacq.	materico rovere termo. heat-treat. oak textured f.
						superfici UP UP surface	
<b>P.   D. 362</b>							
L. 320	SP1C0132F	196	285	339	364	272	156
L. 480	SP1C0134F	251	361	430	464	360	177
L. 640	SP1C0135F	301	429	513	556	445	198
* L. 960	SP1C0136F	425	573	683	752	622	253
+							
<b>Spalla   Side panel</b>	SP1S3T33F	84	130	156	170	134	65
<b>P.   D. 458</b>							
L. 320	SP1C0142F	208	307	367	392	304	168
L. 480	SP1C0144F	269	393	468	510	412	189
L. 640	SP1C0145F	329	471	563	614	503	218
* L. 960	SP1C0146F	471	645	767	850	706	281
+							
<b>Spalla   Side panel</b>	SP1S3T43F	97	146	175	193	159	76

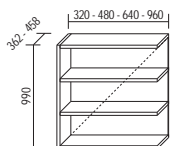



## COLONNE A TERRA | FREE-STANDING COLUMNS

## H. 1310

N.B: Si consiglia l'abbinamento tra melaminico rovere termotrattato ed essenza rovere termotrattato | Matching melamine heat-treated oak and wood veneer heat-treated oak is not recommended.

	codice code	lacc. opaco matt lacq.	essenza cat. 1 wood cat. 1	essenza cat. 2 wood cat. 2	rovere lacc. matt lacq. oak	lacc. lucido glossy lacq.	materico rovere termo. heat-treat. oak textured f.
* I ripiani di lunghezza superiore a 930 devono essere necessariamente intervallati da divisioni tra ripiani o divisioni a terra. * Shelves longer than 930 mm, must be interspersed with partitions between the shelves or free-standing partitions.						superfici UP UP surface	
Colonna a terra - completamente schienata Free-standing column - provided with a back panel							
<b>P.   D. 362</b>							
L. 320	SP1C0132I	244	360	428	460	339	194
L. 480	SP1C0134I	313	448	535	578	451	218
L. 640	SP1C0135I	376	532	636	692	561	243
* L. 960	SP1C0136I	534	715	852	939	780	312
+							
<b>Spalla   Side panel</b>	SP1S3T33I	101	157	188	207	158	74
<b>P.   D. 458</b>							
L. 320	SP1C0142I	259	386	461	493	380	209
L. 480	SP1C0144I	336	488	582	634	517	233
L. 640	SP1C0145I	412	586	700	766	633	268
* L. 960	SP1C0146I	591	803	954	1.059	885	347
+							
<b>Spalla   Side panel</b>	SP1S3T43I	116	178	213	236	197	86

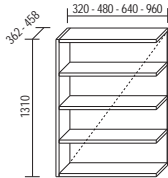

## COLONNE A TERRA | FREE-STANDING COLUMNS

## H. 1630

\* I ripiani di lunghezza superiore a 930 devono essere necessariamente intervallati da divisioni tra ripiani o divisioni a terra.  
\* Shelves longer than 930 mm, must be interspersed with partitions between the shelves or free-standing partitions.

	codice code	lacc. opaco matt lacq.	essenza cat. 1 wood cat. 1	essenza cat. 2 wood cat. 2	rovere lacc. matt lacq. oak	lacc. lucido glossy lacq.	materico rovere termo. heat-treat. oak textured f.
* I ripiani di lunghezza superiore a 930 devono essere necessariamente intervallati da divisioni tra ripiani o divisioni a terra. * Shelves longer than 930 mm, must be interspersed with partitions between the shelves or free-standing partitions.						superfici UP UP surface	
Colonna a terra - completamente schienata Free-standing column - provided with a back panel							
<b>P.   D. 362</b>							
L. 320	SP1C0132K	292	429	510	548	406	228
L. 480	SP1C0134K	378	539	644	698	544	259
L. 640	SP1C0135K	456	639	765	831	677	289
* L. 960	SP1C0136K	648	857	1.022	1.128	946	370
+							
<b>Spalla   Side panel</b>	SP1S3T33K	118	183	220	242	199	83
<b>P.   D. 458</b>							
L. 320	SP1C0142K	310	459	548	586	456	246
L. 480	SP1C0144K	406	587	700	764	624	277
L. 640	SP1C0145K	500	705	843	921	763	319
* L. 960	SP1C0146K	716	961	1.142	1.270	1.072	412
+							
<b>Spalla   Side panel</b>	SP1S3T43K	133	212	255	285	236	93

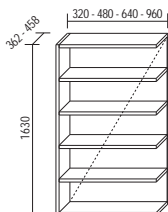

## COLONNE A TERRA | FREE-STANDING COLUMNS

H. 1950

N.B: Si consiglia l'abbinamento tra melaminico rovere termotrattato ed essenza rovere termotrattato | Matching melamine heat-treated oak and wood veneer heat-treated oak is not recommended.

	codice code	lacc. opaco matt lacq.	essenza cat. 1 wood cat. 1	essenza cat. 2 wood cat. 2	rovere lacc. matt lacq. oak	lacc. lucido glossy lacq.	materico rovere termo. heat-treat. oak textured f.
* I ripiani di lunghezza superiore a 930 devono essere necessariamente intervallati da divisioni tra ripiani o divisioni a terra. * Shelves longer than 930 mm, must be interspersed with partitions between the shelves or free-standing partitions.						superfici UP UP surface	
Colonna a terra - completamente schienata Free-standing column - provided with a back panel							
	<b>P.   D. 362</b>						
	L. 320	SP1C0132M	355	516	613	658	281
	L. 480	SP1C0134M	458	649	775	838	318
	L. 640	SP1C0135M	552	774	926	1.004	359
	* L. 960	SP1C0136M	775	1.030	1.227	1.351	454
	<b>+</b>						
	<b>Spalla   Side panel</b>	SP1S3T33M	133	209	251	278	92
	<b>P.   D. 458</b>						
	L. 320	SP1C0142M	376	553	660	705	302
	L. 480	SP1C0144M	490	705	841	917	339
	L. 640	SP1C0145M	602	849	1.015	1.107	394
	* L. 960	SP1C0146M	855	1.154	1.371	1.520	503
	<b>+</b>						
	<b>Spalla   Side panel</b>	SP1S3T43M	154	245	294	329	107

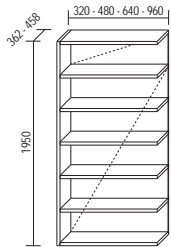

## COLONNE A TERRA | FREE-STANDING COLUMNS

H. 2270

\* I ripiani di lunghezza superiore a 930 devono essere necessariamente intervallati da divisioni tra ripiani o divisioni a terra.  
\* Shelves longer than 930 mm, must be interspersed with partitions between the shelves or free-standing partitions.

Colonna a terra - completamente schienata  
Free-standing column - provided with a back panel

	codice code	lacc. opaco matt lacq.	essenza cat. 1 wood cat. 1	essenza cat. 2 wood cat. 2	rovere lacc. matt lacq. oak	lacc. lucido glossy lacq.	materico rovere termo. heat-treat. oak textured f.
						superfici UP UP surface	
	<b>P.   D. 362</b>						
	L. 320	SP1C0132P	405	591	703	755	320
	L. 480	SP1C0134P	521	741	884	956	361
	L. 640	SP1C0135P	627	881	1.054	1.144	405
	* L. 960	SP1C0136P	884	1.177	1.402	1.545	515
	<b>+</b>						
	<b>Spalla   Side panel</b>	SP1S3T33P	151	245	294	326	100
	<b>P.   D. 458</b>						
	L. 320	SP1C0142P	429	632	755	807	344
	L. 480	SP1C0144P	558	805	959	1.045	385
	L. 640	SP1C0145P	685	968	1.157	1.263	445
	* L. 960	SP1C0146P	975	1.317	1.564	1.736	571
	<b>+</b>						
	<b>Spalla   Side panel</b>	SP1S3T43P	174	286	343	383	116

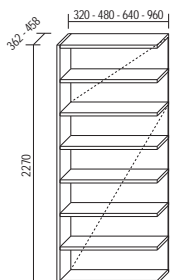

## COLONNE A TERRA | FREE-STANDING COLUMNS

## H. 2590

N.B: Si sconsiglia l'abbinamento tra melaminico rovere termotrattato ed essenza rovere termotrattato | Matching melamine heat-treated oak and wood veneer heat-treated oak is not recommended.

	codice code	lacc. opaco matt lacq.	essenza cat. 1 wood cat. 1	essenza cat. 2 wood cat. 2	rovere lacc. matt lacq. oak	lacc. lucido glossy lacq.	materico rovere termo. heat-treat. oak textured f.
* I ripiani di lunghezza superiore a 930 devono essere necessariamente intervallati da divisioni tra ripiani o divisioni a terra. * Shelves longer than 930 mm, must be interspersed with partitions between the shelves or free-standing partitions.						superfici UP UP surface	
Colonna a terra - completamente schienata Free-standing column - provided with a back panel							
	<b>P.   D. 362</b>						
	L. 320	SP1C0132R	452	660	784	842	354
	L. 480	SP1C0134R	583	830	990	1.072	403
	L. 640	SP1C0135R	703	985	1.178	1.279	450
	* L. 960	SP1C0136R	1.000	1.322	1.575	1.737	577
	<b>+ Spalla   Side panel</b>	SP1S3T33R	168	273	328	363	108
	<b>P.   D. 458</b>						
	L. 320	SP1C0142R	479	705	841	899	381
	L. 480	SP1C0144R	625	902	1.074	1.171	430
	L. 640	SP1C0145R	769	1.084	1.295	1.414	495
	* L. 960	SP1C0146R	1.102	1.478	1.755	1.950	640
	<b>+ Spalla   Side panel</b>	SP1S3T43R	195	320	385	430	127

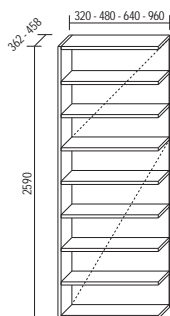

## COLONNE A TERRA | FREE-STANDING COLUMNS

## H. 2910

\* I ripiani di lunghezza superiore a 930 devono essere necessariamente intervallati da divisioni tra ripiani o divisioni a terra.  
\* Shelves longer than 930 mm, must be interspersed with partitions between the shelves or free-standing partitions.

	codice code	lacc. opaco matt lacq.	essenza cat. 1 wood cat. 1	essenza cat. 2 wood cat. 2	rovere lacc. matt lacq. oak	lacc. lucido glossy lacq.	materico rovere termo. heat-treat. oak textured f.
* I ripiani di lunghezza superiore a 930 devono essere necessariamente intervallati da divisioni tra ripiani o divisioni a terra. * Shelves longer than 930 mm, must be interspersed with partitions between the shelves or free-standing partitions.						superfici UP UP surface	
Colonna a terra - completamente schienata Free-standing column - provided with a back panel							
	<b>P.   D. 362</b>						
	L. 320	SP1C0132V	500	735	873	938	392
	L. 480	SP1C0134V	645	917	1.095	1.186	444
	L. 640	SP1C0135V	778	1.088	1.301	1.415	495
	* L. 960	SP1C0136V	1.109	1.464	1.744	1.924	636
	<b>+ Spalla   Side panel</b>	SP1S3T33V	185	303	363	403	120
	<b>P.   D. 458</b>						
	L. 320	SP1C0142V	530	784	935	1.000	422
	L. 480	SP1C0144V	692	997	1.188	1.295	474
	L. 640	SP1C0145V	852	1.199	1.432	1.566	545
	* L. 960	SP1C0146V	1.222	1.636	1.942	2.159	706
	<b>+ Spalla   Side panel</b>	SP1S3T43V	214	354	425	476	140

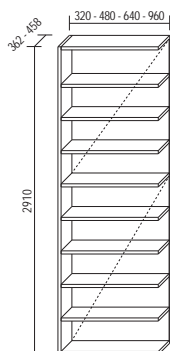

## COLONNE PENSILI | WALL UNIT COLUMNS

## H. 350

N.B: Si sconsiglia l'abbinamento tra melaminico rovere termotrattato ed essenza rovere termotrattato | Matching melamine heat-treated oak and wood veneer heat-treated oak is not recommended.

* I ripiani di lunghezza superiore a 930 devono essere necessariamente intervallati da divisioni tra ripiani o divisioni a terra. * Shelves longer than 930 mm, must be interspersed with partitions between the shelves or free-standing partitions.	codice	lacc. opaco	essenza cat. 1	essenza cat. 2	rovere lacc.	lacc. lucido	materico
	code	matt lacq.	wood cat. 1	wood cat. 2	matt lacq. oak	glossy lacq.	rovere termo.
						superfici UP	heat-treat. oak
						UP surface	textured f.
Colonna pensile - completamente schienata Wall unit columns - provided with back panels							
<b>P.   D. 362</b>							
L. 320	SP1C0232A	99	141	168	180	136	83
L. 480	SP1C0234A	126	180	215	230	181	92
L. 640	SP1C0235A	150	218	261	281	219	107
* L. 960	SP1C0236A	200	281	335	366	302	130
+							
<b>Spalla   Side panel</b>	SP1S3P33A	59	84	99	104	78	53
<b>P.   D. 458</b>							
L. 320	SP1C0242A	105	155	186	198	150	89
L. 480	SP1C0244A	134	196	235	256	205	98
L. 640	SP1C0245A	162	236	283	307	249	117
* L. 960	SP1C0246A	224	321	383	420	344	144
+							
<b>Spalla   Side panel</b>	SP1S3P43A	64	92	110	116	88	59

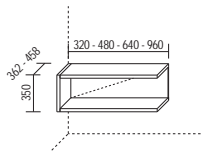

## COLONNE PENSILI | WALL UNIT COLUMNS

## H. 510

\* I ripiani di lunghezza superiore a 930 devono essere necessariamente intervallati da divisioni tra ripiani o divisioni a terra.  
\* Shelves longer than 930 mm, must be interspersed with partitions between the shelves or free-standing partitions.

* I ripiani di lunghezza superiore a 930 devono essere necessariamente intervallati da divisioni tra ripiani o divisioni a terra. * Shelves longer than 930 mm, must be interspersed with partitions between the shelves or free-standing partitions.	codice	lacc. opaco	essenza cat. 1	essenza cat. 2	rovere lacc.	lacc. lucido	materico
	code	matt lacq.	wood cat. 1	wood cat. 2	matt lacq. oak	glossy lacq.	rovere termo.
						superfici UP	heat-treat. oak
						UP surface	textured f.
Colonna pensile - completamente schienata Wall unit columns - provided with back panels							
<b>P.   D. 362</b>							
L. 320	SP1C0232C	106	148	177	190	147	86
L. 480	SP1C0234C	136	194	231	247	194	99
L. 640	SP1C0235C	161	231	275	296	237	111
* L. 960	SP1C0236C	217	303	360	394	326	139
+							
<b>Spalla   Side panel</b>	SP1S3P33C	70	98	116	124	94	60
<b>P.   D. 458</b>							
L. 320	SP1C0242C	112	162	195	208	161	92
L. 480	SP1C0244C	144	210	251	273	218	105
L. 640	SP1C0245C	173	249	297	322	267	121
* L. 960	SP1C0246C	241	343	408	448	368	153
+							
<b>Spalla   Side panel</b>	SP1S3P43C	76	108	129	139	110	66

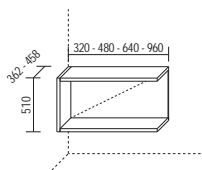

## COLONNE PENSILI | WALL UNIT COLUMNS

## H. 670

N.B: Si consiglia l'abbinamento tra melaminico rovere termotrattato ed essenza rovere termotrattato | Matching melamine heat-treated oak and wood veneer heat-treated oak is not recommended.

\* I ripiani di lunghezza superiore a 930 devono essere necessariamente intervallati da divisioni tra ripiani o divisioni a terra.  
\* Shelves longer than 930 mm, must be interspersed with partitions between the shelves or free-standing partitions.

Colonna pensile - completamente schienata  
Wall unit columns - provided with back panels

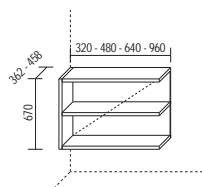

	codice code	lacc. opaco matt lacq.	essenza cat. 1 wood cat. 1	essenza cat. 2 wood cat. 2	rovere lacc. matt lacq. oak	lacc. lucido glossy lacq.	materico rovere termo. heat-treat. oak textured f.
<p><b>P.   D. 362</b></p> <p>L. 320 SP1C0232D <b>149</b> <b>216</b> <b>258</b> <b>277</b> <b>204</b> <b>122</b></p> <p>L. 480 SP1C0234D <b>189</b> <b>272</b> <b>324</b> <b>348</b> <b>271</b> <b>135</b></p> <p>L. 640 SP1C0235D <b>225</b> <b>325</b> <b>389</b> <b>421</b> <b>332</b> <b>153</b></p> <p>* L. 960 SP1C0236D <b>309</b> <b>428</b> <b>510</b> <b>560</b> <b>459</b> <b>191</b></p> <p>+</p> <p><b>Spalla   Side panel</b> SP1S3P33D <b>78</b> <b>112</b> <b>132</b> <b>142</b> <b>112</b> <b>66</b></p>							
<p><b>P.   D. 458</b></p> <p>L. 320 SP1C0242D <b>158</b> <b>234</b> <b>281</b> <b>300</b> <b>227</b> <b>131</b></p> <p>L. 480 SP1C0244D <b>202</b> <b>296</b> <b>353</b> <b>384</b> <b>309</b> <b>144</b></p> <p>L. 640 SP1C0245D <b>245</b> <b>355</b> <b>425</b> <b>463</b> <b>376</b> <b>168</b></p> <p>* L. 960 SP1C0246D <b>344</b> <b>484</b> <b>576</b> <b>636</b> <b>522</b> <b>212</b></p> <p>+</p> <p><b>Spalla   Side panel</b> SP1S3P43D <b>86</b> <b>126</b> <b>150</b> <b>161</b> <b>130</b> <b>73</b></p>							

## COLONNE PENSILI | WALL UNIT COLUMNS

## H. 990

\* I ripiani di lunghezza superiore a 930 devono essere necessariamente intervallati da divisioni tra ripiani o divisioni a terra.  
\* Shelves longer than 930 mm, must be interspersed with partitions between the shelves or free-standing partitions.

Colonna pensile - completamente schienata  
Wall unit columns - provided with back panels

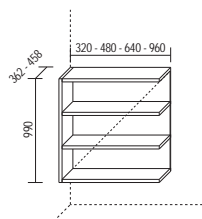

	codice code	lacc. opaco matt lacq.	essenza cat. 1 wood cat. 1	essenza cat. 2 wood cat. 2	rovere lacc. matt lacq. oak	lacc. lucido glossy lacq.	materico rovere termo. heat-treat. oak textured f.
<p><b>P.   D. 362</b></p> <p>L. 320 SP1C0232F <b>196</b> <b>285</b> <b>339</b> <b>364</b> <b>272</b> <b>156</b></p> <p>L. 480 SP1C0234F <b>251</b> <b>361</b> <b>430</b> <b>464</b> <b>360</b> <b>177</b></p> <p>L. 640 SP1C0235F <b>301</b> <b>429</b> <b>513</b> <b>556</b> <b>445</b> <b>198</b></p> <p>* L. 960 SP1C0236F <b>425</b> <b>573</b> <b>683</b> <b>752</b> <b>622</b> <b>253</b></p> <p>+</p> <p><b>Spalla   Side panel</b> SP1S3P33F <b>93</b> <b>140</b> <b>166</b> <b>180</b> <b>144</b> <b>75</b></p>							
<p><b>P.   D. 458</b></p> <p>L. 320 SP1C0242F <b>208</b> <b>307</b> <b>367</b> <b>392</b> <b>304</b> <b>168</b></p> <p>L. 480 SP1C0244F <b>269</b> <b>393</b> <b>468</b> <b>510</b> <b>412</b> <b>189</b></p> <p>L. 640 SP1C0245F <b>329</b> <b>471</b> <b>563</b> <b>614</b> <b>503</b> <b>218</b></p> <p>* L. 960 SP1C0246F <b>471</b> <b>645</b> <b>767</b> <b>850</b> <b>706</b> <b>281</b></p> <p>+</p> <p><b>Spalla   Side panel</b> SP1S3P43F <b>106</b> <b>156</b> <b>185</b> <b>202</b> <b>169</b> <b>86</b></p>							

## COLONNE PENSILI | WALL UNIT COLUMNS

H. 1310

N.B: Si sconsiglia l'abbinamento tra melaminico rovere termotrattato ed essenza rovere termotrattato | Matching melamine heat-treated oak and wood veneer heat-treated oak is not recommended.

\* I ripiani di lunghezza superiore a 930 devono essere necessariamente intervallati da divisioni tra ripiani o divisioni a terra.  
\* Shelves longer than 930 mm, must be interspersed with partitions between the shelves or free-standing partitions.

Colonna pensile - completamente schienata  
Wall unit columns - provided with back panels

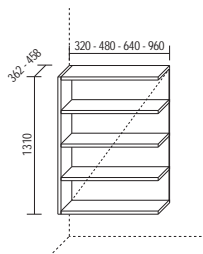

	codice code	lacc. opaco matt lacq.	essenza cat. 1 wood cat. 1	essenza cat. 2 wood cat. 2	rovere lacc. matt lacq. oak	lacc. lucido glossy lacq.	materico rovere termo. heat-treat. oak textured f.
						superfici UP UP surface	
<b>P.   D. 362</b>							
L. 320	SP1C0232I	244	360	428	460	339	194
L. 480	SP1C0234I	313	448	535	578	451	218
L. 640	SP1C0235I	376	532	636	692	561	243
* L. 960	SP1C0236I	534	715	852	939	780	312
+							
Spalla   Side panel	SP1S3P33I	111	167	198	216	168	84
<b>P.   D. 458</b>							
L. 320	SP1C0242I	259	386	461	493	380	209
L. 480	SP1C0244I	336	488	582	634	517	233
L. 640	SP1C0245I	412	586	700	766	633	268
* L. 960	SP1C0246I	591	803	954	1.059	885	347
+							
Spalla   Side panel	SP1S3P43I	126	187	223	246	207	96

## COLONNE PENSILI | WALL UNIT COLUMNS

H. 1630

\* I ripiani di lunghezza superiore a 930 devono essere necessariamente intervallati da divisioni tra ripiani o divisioni a terra.  
\* Shelves longer than 930 mm, must be interspersed with partitions between the shelves or free-standing partitions.

Colonna pensile - completamente schienata  
Wall unit columns - provided with back panels

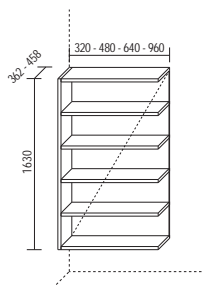

	codice code	lacc. opaco matt lacq.	essenza cat. 1 wood cat. 1	essenza cat. 2 wood cat. 2	rovere lacc. matt lacq. oak	lacc. lucido glossy lacq.	materico rovere termo. heat-treat. oak textured f.
						superfici UP UP surface	
<b>P.   D. 362</b>							
L. 320	SP1C0232K	292	429	510	548	406	228
L. 480	SP1C0234K	378	539	644	698	544	259
L. 640	SP1C0235K	456	639	765	831	677	289
* L. 960	SP1C0236K	648	857	1.022	1.128	946	370
+							
Spalla   Side panel	SP1S3P33K	128	193	229	252	209	92
<b>P.   D. 458</b>							
L. 320	SP1C0242K	310	459	548	586	456	246
L. 480	SP1C0244K	406	587	700	764	624	277
L. 640	SP1C0245K	500	705	843	921	763	319
* L. 960	SP1C0246K	716	961	1.142	1.270	1.072	412
+							
Spalla   Side panel	SP1S3P43K	143	222	265	294	246	103

## COLONNE PENSILI | WALL UNIT COLUMNS

### H. 1950

N.B: Si consiglia l'abbinamento tra melaminico rovere termotrattato ed essenza rovere termotrattato | Matching melamine heat-treated oak and wood veneer heat-treated oak is not recommended.

\* I ripiani di lunghezza superiore a 930 devono essere necessariamente intervallati da divisioni tra ripiani o divisioni a terra.  
\* Shelves longer than 930 mm, must be interspersed with partitions between the shelves or free-standing partitions.

Colonna pensile - completamente schienata  
Wall unit columns - provided with back panels

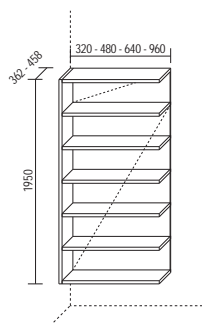

	codice code	lacc. opaco matt lacq.	essenza cat. 1 wood cat. 1	essenza cat. 2 wood cat. 2	rovere lacc. matt lacq. oak	lacc. lucido glossy lacq.	materico rovere termo. heat-treat. oak textured f.
						superfici UP UP surface	
<b>P.   D. 362</b>							
L. 320	SP1C0232M	355	516	613	658	490	281
L. 480	SP1C0234M	458	649	775	838	656	318
L. 640	SP1C0235M	552	774	926	1.004	812	359
* L. 960	SP1C0236M	775	1.030	1.227	1.351	1.132	454
+							
<b>Spalla   Side panel</b>	SP1S3P33M	143	219	261	288	241	102
<b>P.   D. 458</b>							
L. 320	SP1C0242M	376	553	660	705	547	302
L. 480	SP1C0244M	490	705	841	917	748	339
L. 640	SP1C0245M	602	849	1.015	1.107	913	394
* L. 960	SP1C0246M	855	1.154	1.371	1.520	1.279	503
+							
<b>Spalla   Side panel</b>	SP1S3P43M	164	254	304	339	285	117

## COLONNE PENSILI | WALL UNIT COLUMNS

### H. 2270

\* I ripiani di lunghezza superiore a 930 devono essere necessariamente intervallati da divisioni tra ripiani o divisioni a terra.  
\* Shelves longer than 930 mm, must be interspersed with partitions between the shelves or free-standing partitions.

Colonna pensile - completamente schienata  
Wall unit columns - provided with back panels

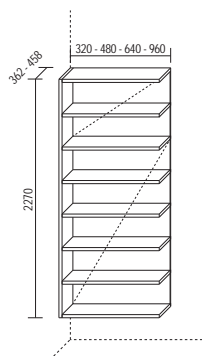

	codice code	lacc. opaco matt lacq.	essenza cat. 1 wood cat. 1	essenza cat. 2 wood cat. 2	rovere lacc. matt lacq. oak	lacc. lucido glossy lacq.	materico rovere termo. heat-treat. oak textured f.
						superfici UP UP surface	
<b>P.   D. 362</b>							
L. 320	SP1C0232P	405	591	703	755	558	320
L. 480	SP1C0234P	521	741	884	956	746	361
L. 640	SP1C0235P	627	881	1.054	1.144	925	405
* L. 960	SP1C0236P	884	1.177	1.402	1.545	1.289	515
+							
<b>Spalla   Side panel</b>	SP1S3P33P	160	254	304	335	273	110
<b>P.   D. 458</b>							
L. 320	SP1C0242P	429	632	755	807	624	344
L. 480	SP1C0244P	558	805	959	1.045	852	385
L. 640	SP1C0245P	685	968	1.157	1.263	1.040	445
* L. 960	SP1C0246P	975	1.317	1.564	1.736	1.457	571
+							
<b>Spalla   Side panel</b>	SP1S3P43P	184	295	353	393	326	126

## COLONNE PENSILI | WALL UNIT COLUMNS

H. 2590

N.B: Si consiglia l'abbinamento tra melaminico rovere termotrattato ed essenza rovere termotrattato | Matching melamine heat-treated oak and wood veneer heat-treated oak is not recommended.

\* I ripiani di lunghezza superiore a 930 devono essere necessariamente intervallati da divisioni tra ripiani o divisioni a terra.  
\* Shelves longer than 930 mm, must be interspersed with partitions between the shelves or free-standing partitions.

Colonna pensile - completamente schienata  
Wall unit columns - provided with back panels

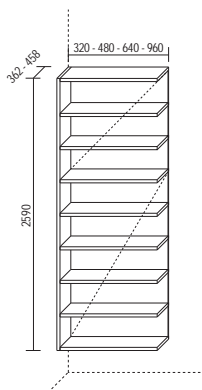

**P. | D. 362**

	codice code	lacc. opaco matt lacq.	essenza cat. 1 wood cat. 1	essenza cat. 2 wood cat. 2	rovere lacc. matt lacq. oak	lacc. lucido glossy lacq.	materico rovere termo. heat-treat. oak textured f.
L. 320	SP1C0232R	452	660	784	842	626	354
L. 480	SP1C0234R	583	830	990	1.072	835	403
L. 640	SP1C0235R	703	985	1.178	1.279	1.038	450
* L. 960	SP1C0236R	1.000	1.322	1.575	1.737	1.452	577

+

<b>Spalla   Side panel</b>	SP1S3P33R	178	282	337	373	307	118
----------------------------	-----------	-----	-----	-----	-----	-----	-----

**P. | D. 458**

L. 320	SP1C0242R	479	705	841	899	701	381
L. 480	SP1C0244R	625	902	1.074	1.171	955	430
L. 640	SP1C0245R	769	1.084	1.295	1.414	1.167	495
* L. 960	SP1C0246R	1.102	1.478	1.755	1.950	1.641	640

+

<b>Spalla   Side panel</b>	SP1S3P43R	205	330	395	440	366	137
----------------------------	-----------	-----	-----	-----	-----	-----	-----

## COLONNE PENSILI | WALL UNIT COLUMNS

H. 2910

\* I ripiani di lunghezza superiore a 930 devono essere necessariamente intervallati da divisioni tra ripiani o divisioni a terra.  
\* Shelves longer than 930 mm, must be interspersed with partitions between the shelves or free-standing partitions.

Colonna pensile - completamente schienata  
Wall unit columns - provided with back panels

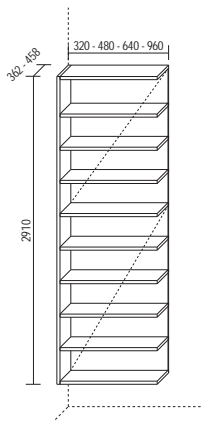

**P. | D. 362**

	codice code	lacc. opaco matt lacq.	essenza cat. 1 wood cat. 1	essenza cat. 2 wood cat. 2	rovere lacc. matt lacq. oak	lacc. lucido glossy lacq.	materico rovere termo. heat-treat. oak textured f.
L. 320	SP1C0232V	500	735	873	938	693	392
L. 480	SP1C0234V	645	917	1.095	1.186	926	444
L. 640	SP1C0235V	778	1.088	1.301	1.415	1.154	495
* L. 960	SP1C0236V	1.109	1.464	1.744	1.924	1.610	636

+

<b>Spalla   Side panel</b>	SP1S3P33V	195	313	373	413	340	130
----------------------------	-----------	-----	-----	-----	-----	-----	-----

**P. | D. 458**

L. 320	SP1C0242V	530	784	935	1.000	777	422
L. 480	SP1C0244V	692	997	1.188	1.295	1.060	474
L. 640	SP1C0245V	852	1.199	1.432	1.566	1.297	545
* L. 960	SP1C0246V	1.222	1.636	1.942	2.159	1.820	706

+

<b>Spalla   Side panel</b>	SP1S3P43V	224	363	435	485	408	150
----------------------------	-----------	-----	-----	-----	-----	-----	-----



# DALL'AGNESE SPEED

**ATTENZIONE:** indicare il verso d'apertura (dx o sx) in corrispondenza delle ante / **ATTENTION:** specify the opening direction (rh or lh) for the doors.  
 Specificare il tipo di frontale - CA: cassello - AL: anta legno batti. - AV: anta vetro batti. - A: ribalta verso l'alto - A: ribalta verso il basso - ALS: anta legno scor. - AVS: anta vetro scor.  
 Specify the front type - CA: drawer - CE: deep drawer - AL: wooden hinged door - AV: glass hinged door - A: flapdoor opening upward - A: flapdoor opening downward - ALS: sliding wooden door - AVS: sliding glass door

Cliente / Customer: \_\_\_\_\_  
 Provincia-Stato / Province-State: \_\_\_\_\_  
 Data / Date: \_\_\_\_\_  
 Riferimento / Reference: \_\_\_\_\_  
 Consegna / Delivery: \_\_\_\_\_

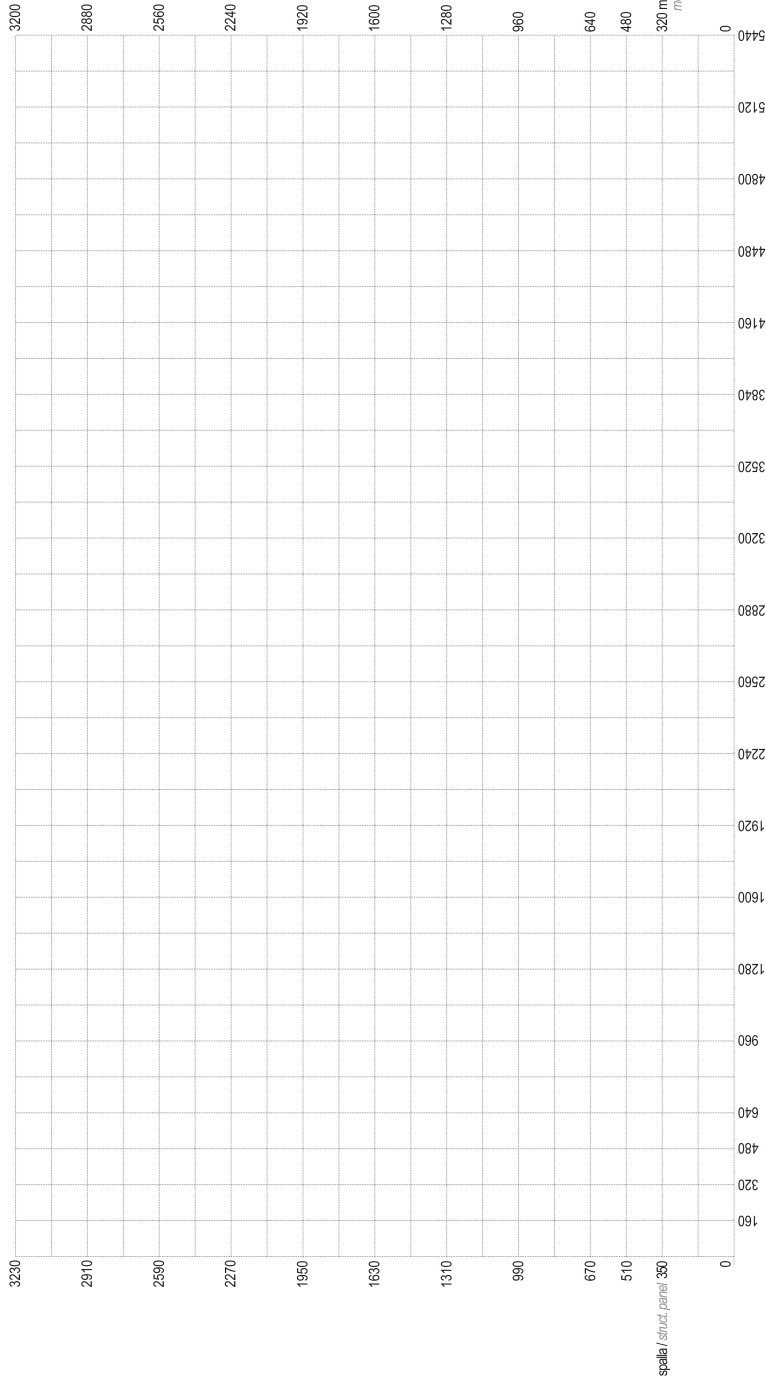

N.B.: La larghezza totale della composizione si ottiene aggiungendo alla somma dei moduli lo spessore della spalla finale da 30 mm (Es. 3520 + 30 = 3550)  
 N.B.: La larghezza totale della composizione si ottiene aggiungendo alla somma dei moduli lo spessore della spalla finale da 30 mm (Es. 3520 + 30 = 3550)

	l. opaco mat. lacq.	essenza wood	rovere l. mat. lacq.	l. lucido UP mat. lacq.	l. lucido UP mat. lacq.
Struttura Structure	<input type="checkbox"/>	<input type="checkbox"/>	<input type="checkbox"/>	<input type="checkbox"/>	<input type="checkbox"/>
Schiena Backs	<input type="checkbox"/>	<input type="checkbox"/>	<input type="checkbox"/>	<input type="checkbox"/>	<input type="checkbox"/>
Frontali legno Wooden fronts	<input type="checkbox"/>	<input type="checkbox"/>	<input type="checkbox"/>	<input type="checkbox"/>	<input type="checkbox"/>
Top Tops	<input type="checkbox"/>	<input type="checkbox"/>	<input type="checkbox"/>	<input type="checkbox"/>	<input type="checkbox"/>
Mediacenter Mediacenter	<input type="checkbox"/>	<input type="checkbox"/>	<input type="checkbox"/>	<input type="checkbox"/>	<input type="checkbox"/>
Schiena per TV TV back panel	<input type="checkbox"/>	<input type="checkbox"/>	<input type="checkbox"/>	<input type="checkbox"/>	<input type="checkbox"/>
Piano sporgente Protruding bench	<input type="checkbox"/>	<input type="checkbox"/>	<input type="checkbox"/>	<input type="checkbox"/>	<input type="checkbox"/>
Piano scrittoio Desk top	<input type="checkbox"/>	<input type="checkbox"/>	<input type="checkbox"/>	<input type="checkbox"/>	<input type="checkbox"/>
Elementi a giorno Open elements	<input type="checkbox"/>	<input type="checkbox"/>	<input type="checkbox"/>	<input type="checkbox"/>	<input type="checkbox"/>
El. in metallo Metal elements	<input type="checkbox"/>	<input type="checkbox"/>	<input type="checkbox"/>	<input type="checkbox"/>	<input type="checkbox"/>
Contentori sporgenti Jutting storage units	<input type="checkbox"/>	<input type="checkbox"/>	<input type="checkbox"/>	<input type="checkbox"/>	<input type="checkbox"/>

**Note / Notes** \_\_\_\_\_

**Maniglie / Handles**

Apertura "push and pull" / "Push and pull" opening

Apertura con maniglia - specificare tipologia e finitura / Opening with handle - specify typology and finish:

**Frontali battenti vetro / Glass regular front parts**

Telaio Slim - finitura / Slim Frame - finish:

bianco / white

brown

Tipologia vetro / Glass typology

Telaio UP brown - vetro trasparente grigio / UP brown frame - grey transparent glass

**Frontali scorrevoli vetro / Glass sliding front parts**

Specchio colore / Mirror colour:

Vetro colore / Glass colour:

Binario / Track:

alluminio / aluminium

lacc. opaco / matt lacq.

# DALL'AGNESE SPEED

Ciente / Customer: \_\_\_\_\_  
 Provincia-Stato / Province-State: \_\_\_\_\_  
 Data / Date: \_\_\_\_\_  
 Riferimento / Reference: \_\_\_\_\_  
 Consegna / Delivery: \_\_\_\_\_

	l. opaco matl. lacq.	essenza wood	rovere l. matl. oak	l. lucido UP glossy L-UP	materico textured l.
Struttura Structure	<input checked="" type="checkbox"/> <i>canape</i> 20259	<input type="checkbox"/>	<input type="checkbox"/>	<input type="checkbox"/>	<input type="checkbox"/>
Schiena Backs	<input checked="" type="checkbox"/> <i>canape</i> 20259	<input type="checkbox"/>	<input type="checkbox"/>	<input type="checkbox"/>	<input type="checkbox"/>
Frontali legno Wooden fronts	<input checked="" type="checkbox"/> <i>canape</i> 20259	<input type="checkbox"/>	<input type="checkbox"/>	<input type="checkbox"/>	<input type="checkbox"/>
Top Tops	<input type="checkbox"/> Altro / other:	<input type="checkbox"/>	<input type="checkbox"/>	<input type="checkbox"/>	<input type="checkbox"/>
Mediacenter Mediacenter	<input checked="" type="checkbox"/> <i>canape</i> 20259	<input type="checkbox"/>	<input type="checkbox"/>	<input type="checkbox"/>	<input type="checkbox"/>
Schiena per TV TV back panel	<input type="checkbox"/>	<input type="checkbox"/>	<input type="checkbox"/>	<input type="checkbox"/>	<input type="checkbox"/>
Piano sporgente Protruding bench	<input type="checkbox"/>	<input type="checkbox"/>	<input type="checkbox"/>	<input type="checkbox"/>	<input type="checkbox"/>
Piano scrittoio Desk top	<input type="checkbox"/>	<input type="checkbox"/>	<input type="checkbox"/>	<input type="checkbox"/>	<input type="checkbox"/>
Elementi a giorno Open elements	<input checked="" type="checkbox"/> <i>canape</i> 20259	<input type="checkbox"/>	<input type="checkbox"/>	<input type="checkbox"/>	<input type="checkbox"/>
El. in metallo Metal elements	<input type="checkbox"/>	<input type="checkbox"/>	<input type="checkbox"/>	<input type="checkbox"/>	<input type="checkbox"/>
Contentori sporgenti Jutting storage units	<input type="checkbox"/>	<input type="checkbox"/>	<input type="checkbox"/>	<input type="checkbox"/>	<input type="checkbox"/>

ATTENZIONE: indicare il verso d'apertura (dx o sx) in corrispondenza delle ante / ATTENTION: specify the opening direction (rh or lh) for the doors.  
 Specificare il tipo di frontale - CA: cassello - AL: anta legno batti. - AV: anta vetro batti. - R: ribalta verso l'alto - S: ribalta verso il basso - ALS: anta legno scor. - AVS: anta vetro scor.  
 Specify the front type - CA: drawer - CE: deep drawer - AL: wooden hinged door - AV: glass hinged door - R: flapdoor opening upward - S: flapdoor opening downward - ALS: sliding wooden door - AVS: sliding glass door

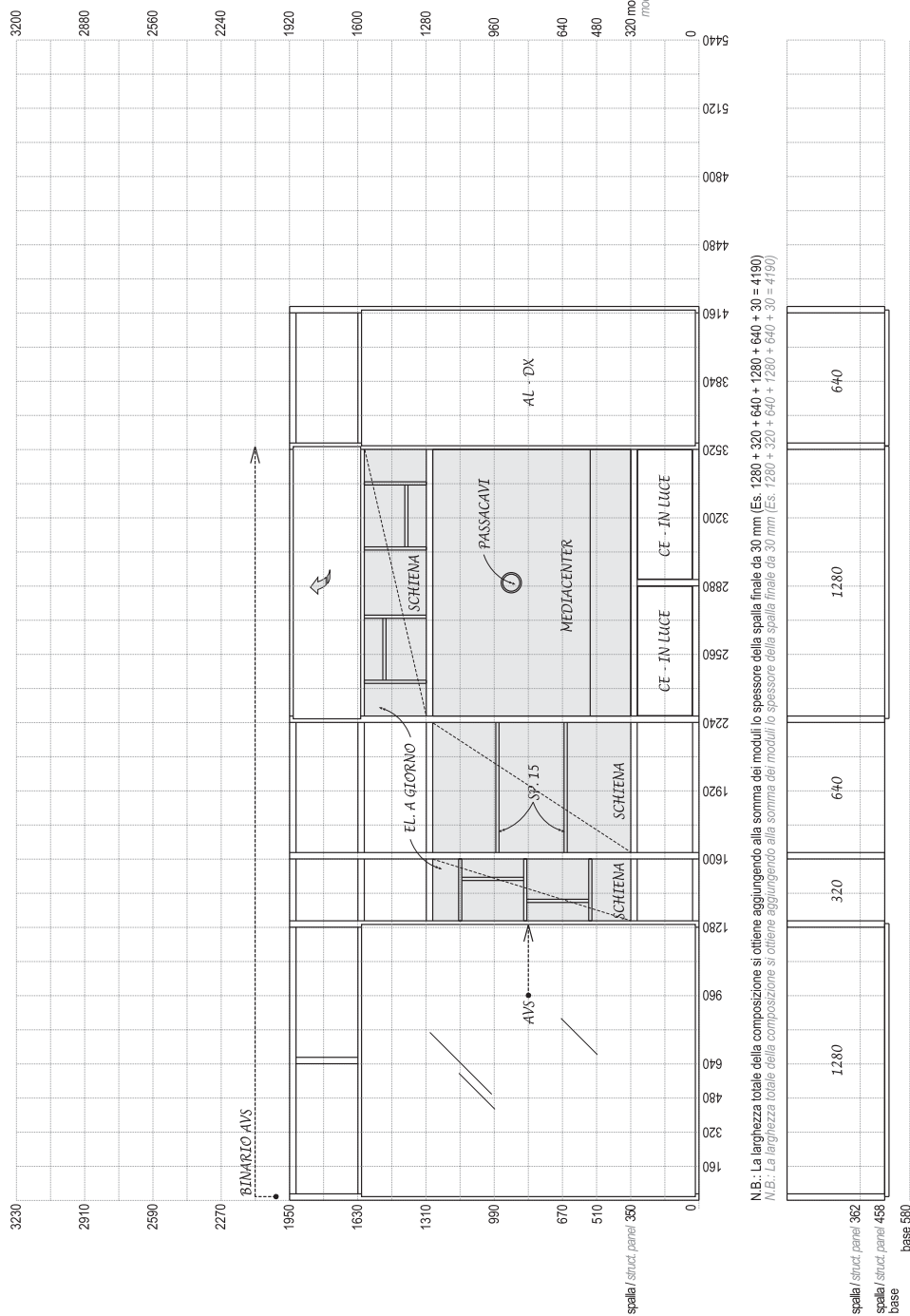

- Note / Notes**
- Apertura "push and pull" / "Push and pull" opening
  - Apertura con maniglia - specificare tipologia e finitura / Opening with handle - specify typology and finish:
- Manglie / Handles**
- Telaio Slim - finitura / Slim Frame - finish:
  - bianco / white
  - brown
- Tipologia vetro / Glass typology:
- Telaio UP brown - vetro trasparente grigio / UP brown frame - grey transparent glass
- Frontali: vetro / Glass front parts**
- Telaio UP brown - vetro trasparente grigio / UP brown frame - grey transparent glass
- Frontali: scorrevoli vetro / Glass sliding front parts**
- Specchio colore / Mirror colour: BRONZO
  - Vetro colore / Glass colour:
  - Bitrato / Track:
    - alluminio / aluminium
    - lacc. opaco / matt lacq. *canape*-20259



**# COMP T** L. 4350 H. 2590 P./D. 362 (pag. 115)  
 Finiture come in foto | Finishes as in photo € 6.511,20  
 Tutta la composizione in lacc. opaco | Whole composition in matt lacq. finish € 6.511,20



**# COMP U** L. 3550 H. 2270 P./D. 362 (pag. 121)  
 Finiture come in foto | Finishes as in photo € 6.708,60  
 Tutta la composizione in lacc. opaco | Whole composition in matt lacq. finish € 6.478,60



**# COMP V** L. 3870 H. 1950 P./D. 362 (pag. 127)  
 Finiture come in foto | Finishes as in photo € 5.044,54  
 Tutta la composizione in lacc. opaco | Whole composition in matt lacq. finish € 5.044,54



**# COMP Z** L. 3550 H. 1950 P./D. 362-458 (pag. 133)  
 Finiture come in foto | Finishes as in photo € 6.667,00  
 Tutta la composizione in lacc. opaco | Whole composition in matt lacq. finish € 6.274,00



**# COMP J** L. 3230 H. 2270 P./D. 362 (pag. 139)  
 Finiture come in foto | Finishes as in photo € 5.125,00  
 Tutta la composizione in lacc. opaco | Whole composition in matt lacq. finish € 4.749,00



**# COMP P** L. 3550 H. 2270 P./D. 362-458 (pag. 145)  
 Finiture come in foto | Finishes as in photo € 7.949,00  
 Tutta la composizione in lacc. opaco | Whole composition in matt lacq. finish € 7.949,00



**# COMP K** L. 4495 H. 1950 P./D. 362-484 (pag. 151)  
 Finiture come in foto | Finishes as in photo € 6.250,00  
 Tutta la composizione in lacc. opaco | Whole composition in matt lacq. finish € 5.983,00

## COMPOSIZIONI CATALOGO "SPEED UP" | "SPEED UP" CATALOGUE COMPOSITIONS

Il prezzo delle composizioni fotografiche Speed UP è calcolato utilizzando basi con frontali a ribalta e con braccetto normale a pistone, escluso di luci led ed accessori (maggiorazione braccetto a filo pag. 157, luci led ed accessori optional pag. 177).  
The price of Speed UP photo composition is calculated on bases with flap doors with standard piston hinges, led lights and accessories not included (surcharge for wire hinge on page 157, led lights and optional accessories on page 177).



**SPEED UP 01** L. 3520 H. 1630 P./D. 362-484 (pag. 76)  
Finiture come in foto | Finishes as in photo € 4.225,00  
Tutta la composizione in lacc. opaco | Whole composition in matt lacq. finish € 3.687,00



**SPEED UP 02** L. 4350 H. 2910 P./D. 362-484 (pag. 82)  
Finiture come in foto | Finishes as in photo € 8.891,08  
Tutta la composizione in lacc. opaco | Whole composition in matt lacq. finish € 8.359,20



**SPEED UP 03** L. 3710 H. 1950 P./D. 362 (pag. 88)  
Finiture come in foto | Finishes as in photo € 5.923,00  
Tutta la composizione in lacc. opaco | Whole composition in matt lacq. finish € 5.923,00



**SPEED UP 04** L. 3550 H. 1950 P./D. 362 (pag. 94)  
Finiture come in foto | Finishes as in photo € 5.687,00  
Tutta la composizione in lacc. opaco | Whole composition in matt lacq. finish € 5.607,00



**SPEED UP 05** L. 3870 H. 2590 P./D. 362 (pag. 100)  
Finiture come in foto | Finishes as in photo € 5.892,96  
Tutta la composizione in lacc. opaco | Whole composition in matt lacq. finish € 5.702,40



**SPEED UP 06** L. 2110 H. 1630+320 P./D. 362 (pag. 106)  
Finiture come in foto | Finishes as in photo € 1.585,00  
Tutta la composizione in lacc. opaco | Whole composition in matt lacq. finish € 2.154,00



La fornitura si intende ai prezzi indicati nel listino ed alle condizioni generali di vendita in vigore, che si intendono conosciute ed accettate dal Cliente. I prezzi indicati nel listino, espressi in euro, sono al netto di iva, installazione e/o qualsiasi prestazione ulteriore.

Gli eventuali lavori "fuori misura", se non già regolamentati nel listino, qualora approvati dalla Dall'Agnese s.p.a. verranno quotati e valorizzati caso per caso. Le proposte d'ordine si intendono accettate "salvo approvazione della casa", che la Dall'Agnese s.p.a. si riserva di dare a proprio esclusivo ed insindacabile giudizio. I termini di consegna comunicati al Cliente non possono considerarsi vincolanti in quanto sono subordinati ai tempi di produzione e/o alla disponibilità della merce a magazzino. Qualora per causa di forza maggiore venga previsto un ritardo rispetto ai termini di consegna comunicati verrà concordato tra le parti un nuovo termine. Viene escluso sin d'ora che i ritardi possano dare diritto a qualsiasi risarcimento danni, diretto o indiretto, o annullamento dell'ordine.

La merce viaggia a rischio e pericolo del Cliente quando venduta franco fabbrica. In caso di consegna richiesta in un luogo diverso dal punto di vendita o magazzino dell'acquirente, sarà applicato un supplemento di prezzo, quantificato caso per caso. Resta inteso che la merce viene sempre consegnata "sponda camion". Il Cliente è tenuto ad ispezionare accuratamente la merce ricevuta ed eventuali reclami riguardanti danni subiti durante il trasporto dovranno essere immediatamente segnalati al vettore ed annotati sul documento di trasporto; reclami riguardanti la qualità della merce e/o eventuali difetti di fabbricazione e/o difformità rispetto all'ordine dovranno pervenire entro e non oltre otto giorni dalla consegna alla Dall'Agnese s.p.a. a mezzo raccomandata a.r. Trascorso tale periodo la Dall'Agnese s.p.a. declina qualsiasi propria responsabilità. In relazione ai reclami rivolti nei modi e nei tempi sopra descritti si precisa, comunque, che non si accetteranno resi di merce se non debitamente autorizzati dalla Dall'Agnese s.p.a. La merce, qualora sostituita, dovrà essere immediatamente resa disponibile correttamente imballata dal Cliente, all'atto della sostituzione stessa.

Qualora, per qualsiasi motivo, la merce sostituita non fosse resa disponibile la Dall'Agnese s.p.a. si riserva trascorsi 30 giorni dalla sostituzione, il diritto di esigerne il pagamento.

I resi accettati saranno valutati al prezzo pagato dal Cliente e, se non in buono stato di conservazione, al valore riconosciuto ad insindacabile giudizio dell'ufficio tecnico della Dall'Agnese s.p.a.

Si precisa che anche nel caso di reclami effettuati entro i termini i pagamenti non potranno essere sospesi.

Per le lavorazioni eseguite "fuori misura" e/o personalizzate su richiesta del Cliente non si accettano né resi né richieste di sostituzione. Le modalità di pagamento ed i relativi termini sono quelli concordati previamente con la Dall'Agnese s.p.a. e così come risultanti nella relativa "scheda anagrafica". Sono ritenuti validi solo i pagamenti effettuati direttamente alla Dall'Agnese s.p.a. e/o a propri incaricati e/o propri agenti autorizzati. I titoli di credito eventualmente accettati lo sono sempre "salvo buon fine", il ritardo nei pagamenti, anche di una sola rata, dà diritto alla Dall'Agnese s.p.a. di richiedere l'integrale pagamento del prezzo di vendita con l'aggravio degli interessi legali ed eventuali spese. La merce rimane di proprietà della Dall'Agnese s.p.a. fino all'avvenuto integrale pagamento del prezzo di vendita. Eventuali insolvenze o ritardi nei pagamenti in scadenza da parte del Cliente relativamente a forniture già effettuate, daranno facoltà alla Dall'Agnese s.p.a. di sospendere o annullare l'esecuzione degli ordini in corso anche se già accettati. In riferimento al continuo miglioramento tecnologico del prodotto la Dall'Agnese s.p.a. si riserva il diritto di apportare le modifiche ritenute più opportune alla modellistica, che non abbiano ad incidere negativamente sulla qualità e sull'estetica del prodotto stesso e ciò a proprio insindacabile giudizio e senza la necessità di un preavviso. I colori delle parti verniciate e delle essenze sono indicativi in quanto non è tecnicamente possibile mantenere le stesse tonalità di colore nel tempo; si declina, pertanto, ogni responsabilità per richieste di accoppiamento pervenute in tempi diversi anche se la Dall'Agnese s.p.a. si adopererà a fornire la migliore soluzione tecnica possibile.

È facoltà della Dall'Agnese s.p.a. di apportare, a proprio insindacabile giudizio, in qualsiasi momento e senza preavviso, tutte le variazioni che riterrà necessarie, alle caratteristiche tecniche, costruttive, estetiche dei propri modelli, nonché ai prezzi indicati nel presente listino.

I cataloghi e i dépliant in circolazione hanno valore puramente illustrativo, eventuali inesattezze di stampa e/o di descrizione delle caratteristiche e/o indicazioni di misure non sostanziali dei prodotti non potranno dar luogo a responsabilità in capo alla Dall'Agnese s.p.a.

La Dall'Agnese s.p.a. garantisce i propri prodotti da difetti occulti e per l'utilizzo cui il bene è destinato; i danni derivanti da incuria, negligenza e/o uso improprio non daranno diritto a reclami e/o richieste di danni, diretti o indiretti. Qualsiasi controversia che non fosse possibile risolvere in via bonaria tra le parti sarà devoluta all'unico Foro competente di Pordenone.

The supply is understood to be accordingly the prices specified in the price list and under the general conditions of sale in force, which the Customer is understood to have read and accepted. The prices specified in the price list, expressed in euros, are net of VAT, installation and/or any additional service.

Any custom machining which is not already regulated in the price list, if approved by Dall'Agnese s.p.a., will be quoted and priced on an individual basis. The orders are understood to be accepted "upon company approval", which Dall'Agnese s.p.a. reserves the right to give at its sole and final discretion.

The delivery dates notified to the Customer shall not be considered as binding since they are subject to the production times and/or availability of the goods in the warehouse. If, due to force majeure, a delay is expected with respect to the notified delivery date, a surcharge will be assessed accordingly to the specific case and applied. It is hereby specified that such delay shall not entitle the Customer to any damages, direct or consequential, or the cancellation of the order.

The goods travel at the risk and peril of the Customer when sold ex factory. If delivery is requested to a location other than the buyer's point of sale or warehouse, a price supplement quantified on an individual basis will be applied.

It is understood that the consignment of the goods is always carried as a "tailgate delivery". The Customer is bound to thoroughly inspect the goods received, and any claims concerning damages incurred during transport shall be reported immediately to the carrier and noted on the shipping document; claims concerning the quality of the goods and/or any manufacturing defects and/or discrepancies with respect to the order shall be forwarded to Dall'Agnese s.p.a. within and no later than eight days upon the delivery by means of registered letter with return receipt. Once this period has expired, Dall'Agnese s.p.a. shall accept no liability whatsoever. In regards to claims filed under the terms and conditions above established, however, it is specified that the returned goods will not be accepted unless duly authorized by Dall'Agnese s.p.a.

The goods, in case of replacement, shall be immediately released and duly packed by the same Customer upon the same return.

If, for any reason, the replaced goods are not made available, Dall'Agnese s.p.a. shall be entitled to require the payment of the goods 30 days upon the replacement. The accepted returns will be valued at the price paid by the Customer or, if not in a good preservation status, at the value acknowledged with the final decision of Dall'Agnese s.p.a.'s Technical Department.

It is specified that, even in the case of claims made within the terms, the payments cannot be suspended.

For any bespoke machining and/or customizations executed upon Customer request, neither returns nor requests for replacement will be accepted.

Payment methods and relative terms shall be agreed upon beforehand with Dall'Agnese s.p.a., in accordance to the personal data sheet.

Only the payments made directly to Dall'Agnese s.p.a. and/or its representatives and/or its authorized agents are considered as valid ones. Any credit instrument accepted is subject to clearance. Any delay in payments, even of a single instalment, entitles Dall'Agnese s.p.a. to demand the full settlement of the sales price with the additional increase of legal costs and eventual extra charges. The goods remain full property of Dall'Agnese s.p.a. until receipt of the entire payment of the sales price.

Any insolvency or delays in the payments with reference to supplies already executed shall grant Dall'Agnese s.p.a. the power to suspend or cancel the execution of the orders in progress, even if already accepted. In regards to the continuous technological improvement of the product, Dall'Agnese s.p.a. reserves the right to make any amendment considered as appropriate to the modelling, which shall have no negative impact on the quality or aesthetics of the product itself, at its sole and final discretion without the need for any prior notice.

The colours of the painted parts and wood finishes are representative only, since it is not technically possible to maintain the same shades of colour over time; therefore Dall'Agnese s.p.a. accepts no liability for matching requests received at different times even though Dall'Agnese s.p.a. will work to provide the best technical solution possible. Dall'Agnese s.p.a. has the faculty to make, at its sole and final discretion and at any time without prior notice, all the variations it may consider necessary to the technical, constructional and/or aesthetic characteristics of its models, as well as the prices specified in this price list.

The catalogues and brochures provided are representative only; any unsubstantial inaccuracy in the printing and/or description of the characteristics and/or measurement specifications of the products shall not give rise to liability on the part of Dall'Agnese s.p.a. Dall'Agnese s.p.a. guarantees its products against hidden defects and for the use for which they have been designed; any damage resulting from neglect, negligence and/or improper use shall not entitle the customer to make complaints and/or claims for direct or consequential damages.

Any dispute which cannot be resolved amicably between the parties shall be devolved to the exclusive jurisdiction of Pordenone.