

Chair_One Public Seating System 2 — design Konstantin Grcic, 2006

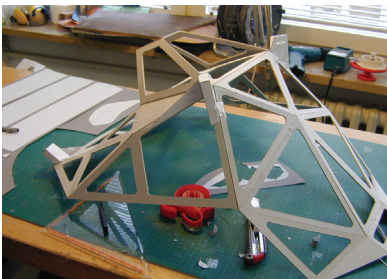

Production Process



Chair_One Public Seating System 2 – design Konstantin Grcic, 2006
 Technical Sheet

Seating system on bar

Material: bases in die-cast aluminium painted in polyester powder, suitable for floor-fixing. Bar in anodised aluminium. Seat in die-cast aluminium treated with sputtered fluorinated titanium and painted in polyester powder. Small table in HPL. Cushions in fabric (Kvadrat "Tempo" or "Gloss 2") or in leather also available. Suitable for outdoor use. Flame-retardant.

Magis logo is stamped on each product of our collection vouching for their originality

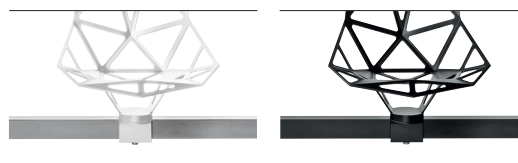
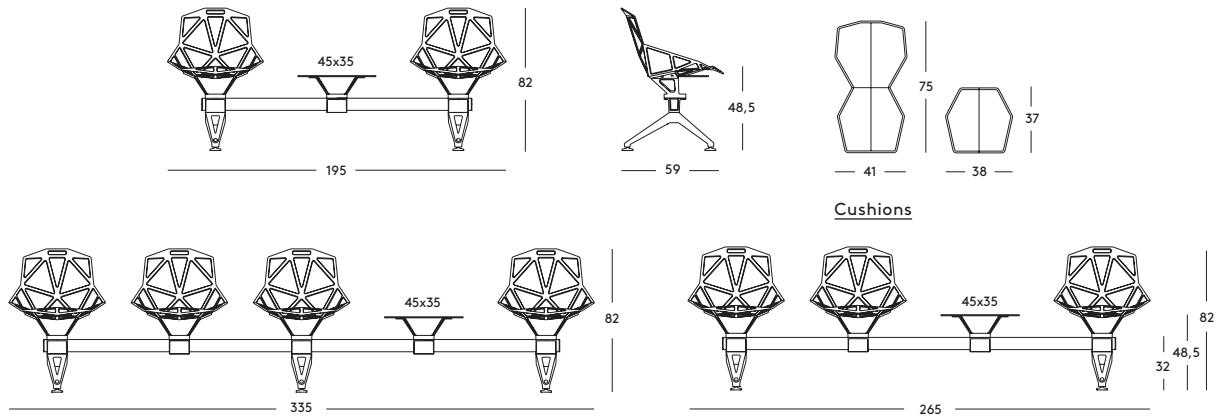

Bar: Natural Glossy
 Seat + Bases: White 5110
 Small table: White 8500

Bar: Matt Black
 Seat + Bases: Black 5130
 Small table: Black 8510

FATIGUE, LOAD AND IMPACT TESTS

ANSI/BIFMA X5.4-2005

Back horizontal static load test UNI 10977/2002, L4

Seat and back static load test UNI 10977/2002, L4

Back vertical static load test UNI 10977/2002, L4

! Chair_One Public Seating System 2 have achieved GREENGUARDGOLD Certification

Back horizontal fatigue test UNI 10977/2002, L4

Combined seat and back fatigue test, UNI 10977/2002, L4

Seat front edge fatigue test UNI 10977/2002, L4

Stability EN 1022/98

Back impact test UNI 10977/2002, L4

Seat impact test UNI 10977/2002, L4



magisdesign.com

The information included in this product sheet are based on the last data in our current pricelist. Magis reserves the right to modify the products without notice.

Designer



Konstantin Grcic

Konstantin Grcic was born in 1965 and studied Design at the Royal College of Art in London. Since setting up his own practice, Konstantin Grcic Industrial Design (KGID), in Munich in 1991, he has developed furniture, products and lighting for some of the leading companies in the design field. Konstantin Grcic defines function in human terms, combining strict forms with considerable mental acuity and humour. Each of his products expresses a careful research into the history of design and architecture, and his passion for technology and materials. Known for his pared-down pieces, Grcic is often called a minimalist, but the designer himself prefers to speak of simplicity.

