

Substance — design Naoto Fukasawa, 2017



I wanted to try working on a chair that has a simple cross junction of two U-shaped legs. Then I wanted to put a simple shell on top. Combining the bending details of the legs and the bottom curve of the shell of this chair creates such a friendly feeling. It is common to have a chair with a shell and legs that extend off the shell whereas this bending detail on Substance gives a fresh quality.

I believe we have successfully produced a sustainable chair.

Naoto Fukasawa



Designer in Magis

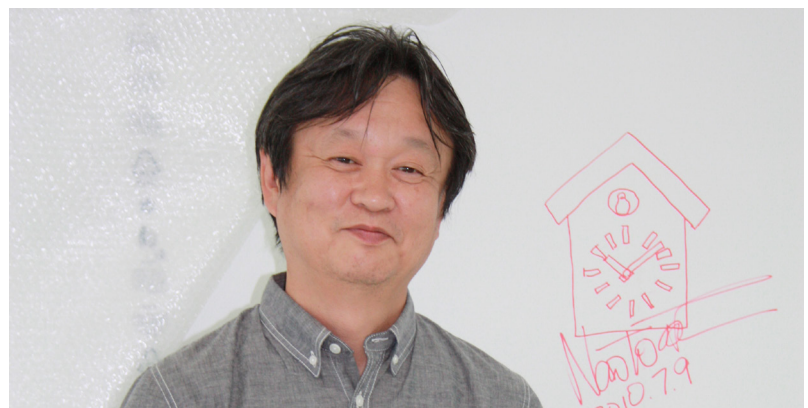

[magisdesign.com](http://magisdesign.com)

**Substance** — design Naoto Fukasawa, 2017  
 Technical Sheet

Chair/chair with arms and armchair

Material: frame in steel tube chromed or painted in polyester powder.  
 Seat in polypropylene.

Magis logo is stamped on each product of our collection vouching for their originality.

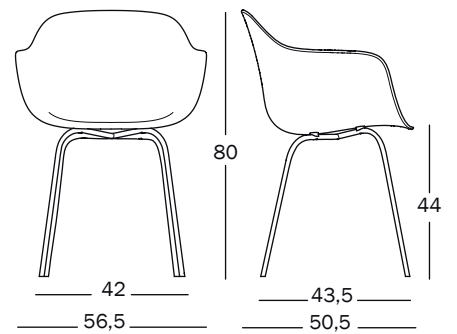
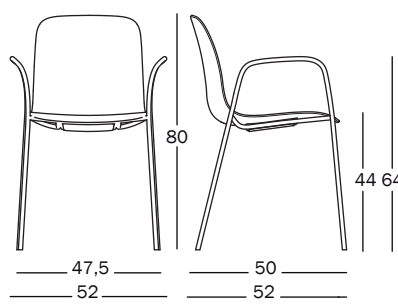
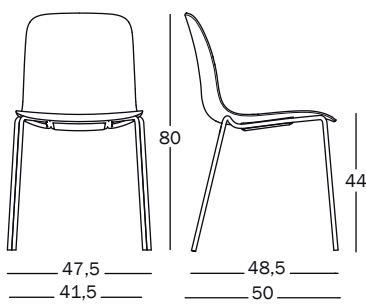

Frame: Chromed  
 Seat: Beige 1452 C



Frame: Chromed  
 Seat: Mustard 1015 C



Frame: Chromed  
 Seat: White 1735 C



Frame: Chromed  
 Seat: Black 1768 C



Frame: White 5110  
 Seat: White 1735 C



Frame: White 5110  
 Seat: Mustard 1015 C



Frame: White 5110  
 Seat: Beige 1452 C



Frame: Black 5140  
 Seat: Beige 1452 C



Frame: Black 5140  
 Seat: Mustard 1015 C



Frame: Black 5140  
 Seat: Black 1768 C



magisdesign.com

The information included in this product sheet are based on the last data in our current pricelist. Magis reserves the right to modify the products without notice.

## Designer



**Naoto Fukasawa**

To design shape is to give form to values that people tacitly share and wish for. Naoto Fukasawa visually captures these values and draws their exact outline. His ability to visualize the unseen outlines of things is not easily worded and described, nonetheless, people are immediately convinced of his ability when they experience his design.

Fukasawa's notions and expressions in approaching the essential values of things through design transcend borders and domains, and his thoughts are well respected internationally.

