

PLANETE

design Stephen BURKS

rochebobois
PARIS



PLANETE

design Stephen BURKS

rochebobois
PARIS



design Stephen BURKS



INFORMATIONS TECHNIQUES / TECHNICAL SPECIFICATIONS / FICHA TECNICA :

Structure : Sapin massif, multiplis de pin et panneaux de particules
 Suspension : Sangles élastiques XL
 Garnissage assise monobloc : Mousse HR 35 kg/m³
 Garnissage dossier et accoudoir monobloc : Mousse HR 18 kg/m³
 Garnissage cale-reins : Flocon de fibres de polyester
 Garnissage coussins indépendants : Plumes et fibres (50% plumes et 50% fibres de polyester)
 Piètement : Hêtre massif teinté noir

Structure: Solid fir wood, pine plywood and engineered composite wood
 Suspension: XL elastic straps
 Monobloc seat cushion: HR foam 35 kg/m³.
 Monobloc back and arm cushion: HR Foam 18 kg/m³
 Lumbar cushions: Polyester fibre flakes
 Independent cushions: Feathers and fibres (50% feathers and 50% polyester fibres)
 Base: Stained solid beech col. black

Estructura: Abeto macizo, multilaminado de pino y paneles de partículas
 Suspensión: Cinchas elásticas XL
 Cojines de asiento monobloc: Espuma HR 35 Kg/ m³.
 Cojines de respaldo y brazo monobloc: Espuma HR 18 kg/m³
 Riñoneras: Copos de fibras de poliéster
 Cojines independientes: Pluma y fibra (50% pluma y 50% fibra poliéster)
 Patas: Haya maciza tintada negro

OBSERVATIONS / OBSERVATIONS / OBSERVACIONES :

- Fabrication Européenne
- Le service « sur-mesure » n'est pas disponible sur ce modèle
- Modèle réalisable dans l'ensemble des revêtements de la collection ROCHE BOBOIS, à l'exception des cuirs d'épaisseur supérieure à 2,0 mm et des tissus extensibles et/ou matelassés

- Manufactured in Europe
- Not customisable
- Model available in all exclusive materials from the ROCHE BOBOIS collection, with the exception of leathers with thickness of more than 2.0 mm and extensible and/or quilted fabrics

- Fabricación europea
- El servicio "a medida" no es posible en este modelo
- Modelo realizable en todas las telas y pieles de la colección ROCHE BOBOIS, excepto las pieles con un grosor superior a 2,0 mm y telas extensibles y/o acolchadas

OPTIONS / OPTIONAL / OPCIONES :

- Confort normal ou ferme
- Standard or firm comfort
- Confort normal o firme

design Stephen BURKS

GRAND CANAPE 3 PLACES
LARGE 3-SEAT SOFA
GRAN SOFA 3 PLAZAS

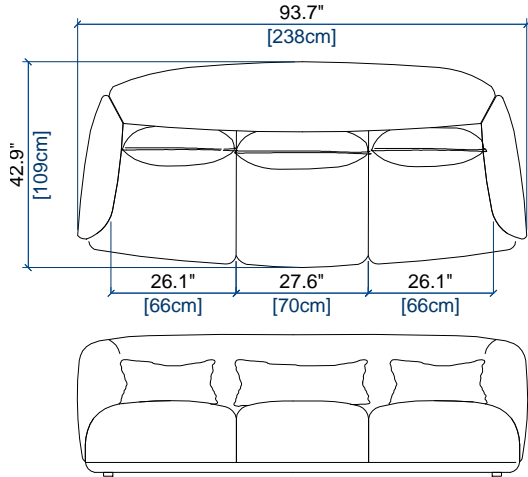

height: 30.3" [77 cm]
seat height: 15.7" [40 cm]

CANAPE 3 PLACES
3-SEAT SOFA
SOFA 3 PLAZAS

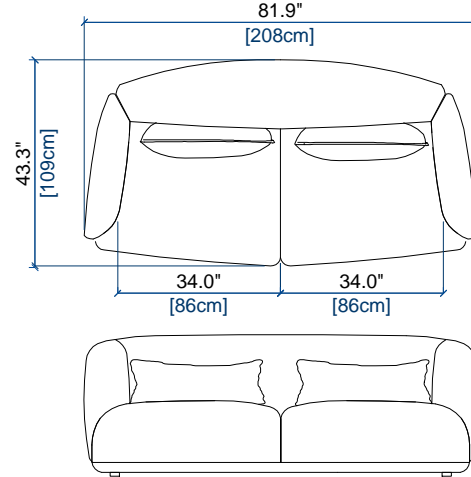

height: 30.3" [77 cm]
seat height: 15.7" [40 cm]

CANAPE 2,5 PLACES
2.5-SEAT SOFA
SOFA 2,5 PLAZAS

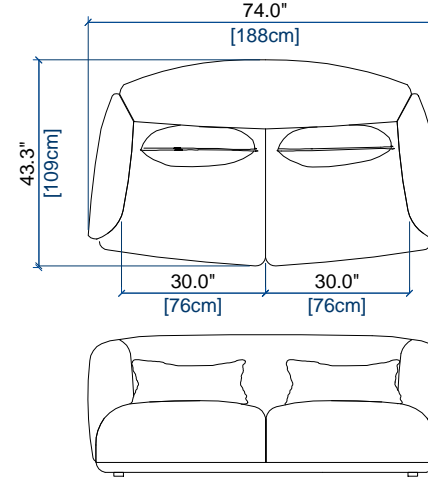

height: 30.3" [77 cm]
seat height: 15.7" [40 cm]

CANAPE 2 PLACES
2-SEAT SOFA
SOFA 2 PLAZAS

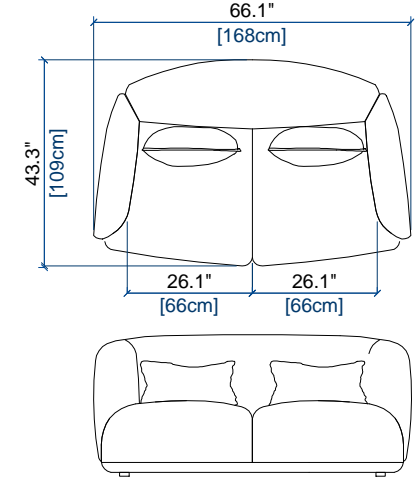

height: 30.3" [77 cm]
seat height: 15.7" [40 cm]

CANAPE 1,5 PLACE
1.5-SEAT SOFA
SOFA 1,5 PLAZA

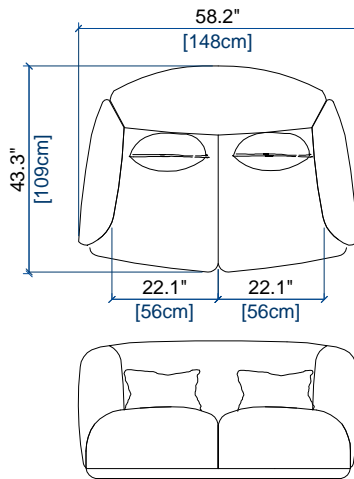

height: 30.3" [77 cm]
seat height: 15.7" [40 cm]

FAUTEUIL
ARMCHAIR
SILLON

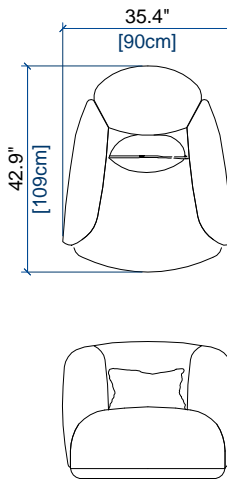

height: 30.3" [77 cm]
seat height: 15.7" [40 cm]

POUF
OTTOMAN
PUF

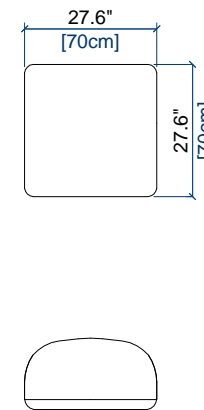

seat height: 15.7" [40 cm]

