

# EDITO ANGLE

rochebobois  
PARIS

design Sacha LAKIC



# EDITO ANGLE

rochebobois  
PARIS

design Sacha LAKIC

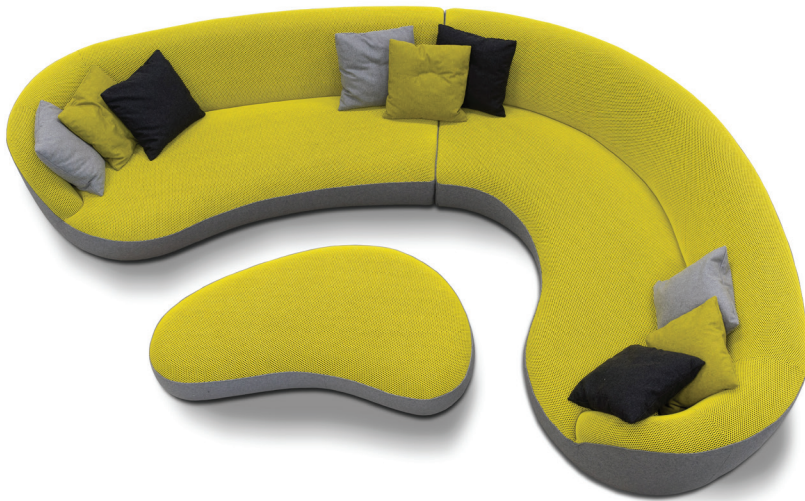

- 38 Bâtard 3 places gauche  
3-seat 1-arm unit left armrest  
Batard 3 plazas izquierdo
  
- 66 Angle/Méridienne maxi droit  
Maxi Corner/Meridienne - Right  
Angulo/Meridienne maxi derecha
  
- 45 Pouf arrondi droit  
Round ottoman – Right  
Puf redondeado derecho

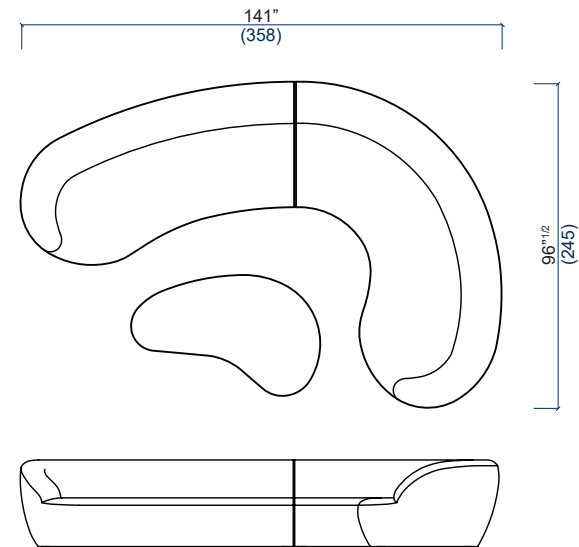

# EDITO ANGLE

rochebobois  
PARIS

design Sacha LAKIC



## FICHE TECHNIQUE / TECHNICAL SPECIFICATIONS / FICHA TECNICA:

Structure : Sapin massif et multiplis de pin

Suspension : Sangles élastiques HR

Garnissage assise : Mousse polyuréthane HR densité 35 kg/m<sup>3</sup> et fibre polyester

Garnissage dossier : Mousse polyuréthane HR densité 45 kg/m<sup>3</sup> et fibre polyester

Piètement : Hêtre massif vernis teinté Wengé

Structure: Solid fir wood and pine plywood

Suspension: HR elastic straps

Seat cushion: HR polyurethane foam 35 kg/m<sup>3</sup> and polyester fibre

Back cushion: HR density polyurethane foam 45 kg/m<sup>3</sup> and polyester fibre

Base: Solid beech with Wenge stain varnish finish

Estructura: Abeto macizo y multilaminado de pino

Suspensión: Cinchas elásticas HR

Interior asiento: Espuma poliuretano HR densidad 35 kg/m<sup>3</sup> y fibra poliéster

Interior respaldo: Espuma poliuretano HR densidad 45 kg/m<sup>3</sup> y fibra poliéster

Patas: Haya maciza barnizada tintada Wengué

## OBSERVATIONS / OBSERVATIONS / OBSERVACIONES :

- Fabrication Européenne
- Modèle réalisable uniquement dans les tissus Techno 2D, Techno 3D et Techno 4D à l'intérieur et dans ces mêmes tissus ou en Laine Edito à l'extérieur
- Manufactured in Europe
- This model can only be upholstered in Techno 2D, Techno 3D and Techno 4D fabrics on the interior and in the same ones or in Laine Edito fabric on the exterior
- Fabricación europea
- Modelo realizable únicamente en las telas Techno 2D, Techno 3D y Techno 4D en el interior y en las mismas telas o en tela Laine Edito en el exterior

design Sacha LAKIC

## INFORMATIONS SUR PASSEPOIL / INFORMATION ABOUT PIPING / INFORMACIONES SOBRE RIBETE

### VERSION STANDARD

PASSEPOIL IDEM TISSU EXTERIEUR  
PIPING MATCHING EXTERIOR FABRIC  
RIBETE COMO TELA EXTERIOR

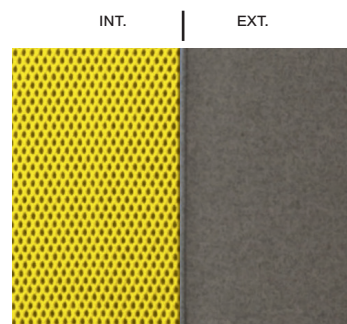

INTERIEUR ET EXTERIEUR  
DANS 2 TISSUS DIFFERENTS

INTERIOR AND EXTERIOR  
IN 2 DIFFERENT FABRICS

INTERIOR Y EXTERIOR  
EN 2 TELAS DIFERENTES

### VERSION 01

PASSEPOIL IDEM TISSU INTERIEUR  
PIPING MATCHING INTERIOR FABRIC  
RIBETE COMO TELA INTERIOR

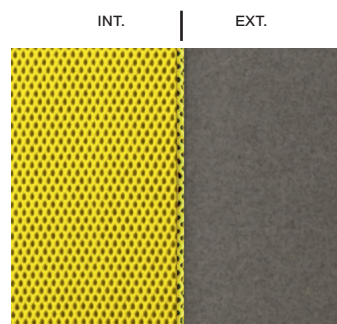

### VERSION 02

PASSEPOIL NOIR  
BLACK PIPING  
RIBETE NEGRO

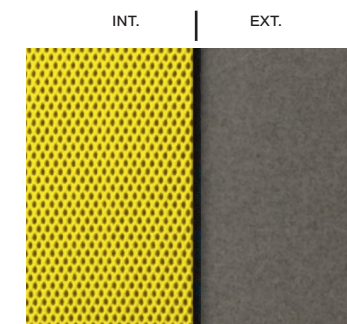

# EDITO ANGLE

design Sacha LAKIC

**33** Bâtard 2,5 places gauche  
2,5-seat 1-arm unit left armrest  
Batard 2,5 plazas izquierdo

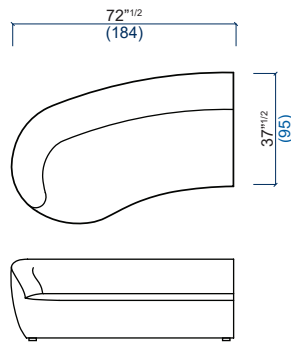
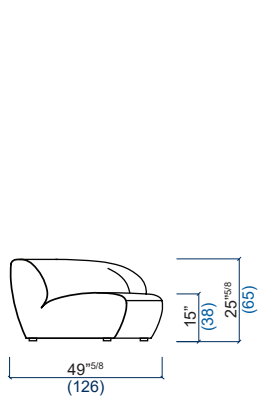

**32** Bâtard 2,5 places droit  
2,5-seat 1-arm unit right armrest  
Batard 2,5 plazas derecho

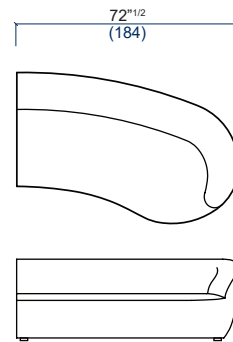

**45** Pouf arrondi droit  
Round ottoman – Right  
Puf redondeado derecho

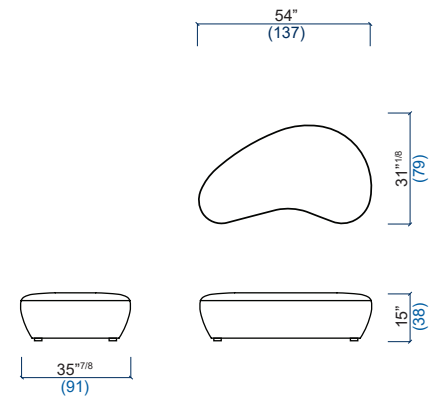

**38** Bâtard 3 places gauche  
3-seat 1-arm unit left armrest  
Batard 3 plazas izquierdo

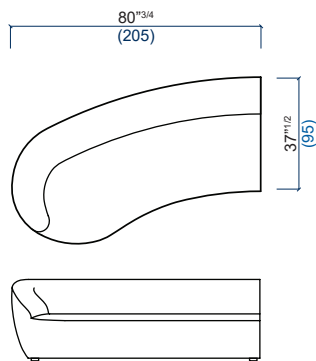
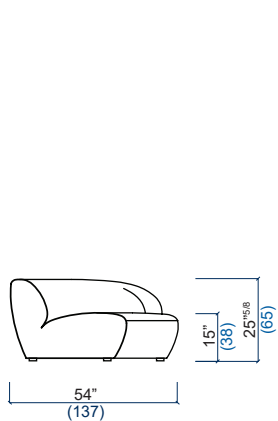

**37** Bâtard 3 places droit  
3-seat 1-arm unit right armrest  
Batard 3 plazas derecho

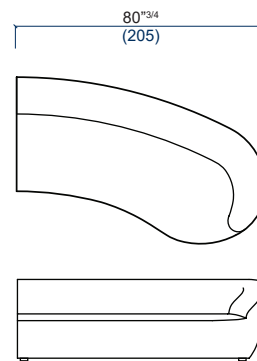

**46** Pouf arrondi gauche  
Round ottoman – Left  
Puf redondeado izquierdo

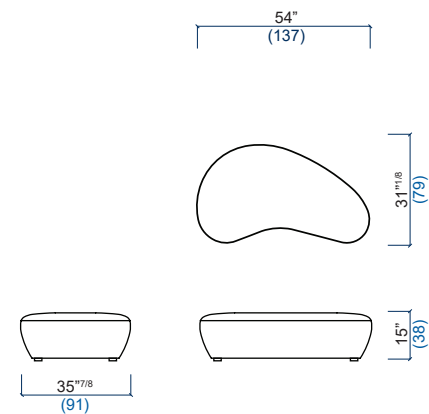

# EDITO ANGLE

design Sacha LAKIC

**63** Angle/Méridienne gauche  
Corner/Meridienne - Left  
Angulo/Meridienne izquierdo

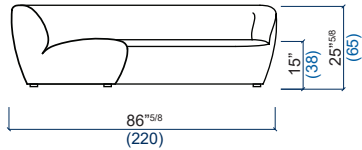
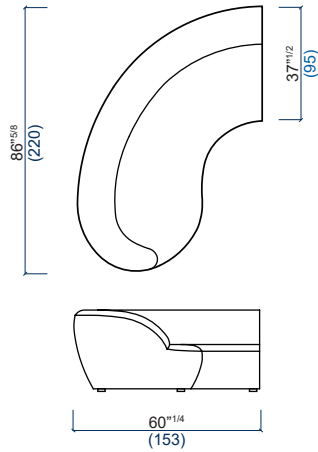

**62** Angle/Méridienne droit  
Corner/Meridienne - Right  
Angulo/Meridienne derecho

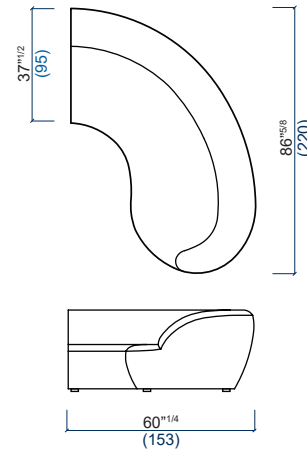

**99** Coussin carré  
Square cushion  
Cojín cuadrado



15 3/4 x 15 3/4  
(40x40)

**67** Angle/Méridienne maxi gauche  
Maxi Corner/Meridienne - Left  
Angulo/Meridienne maxi izquierdo

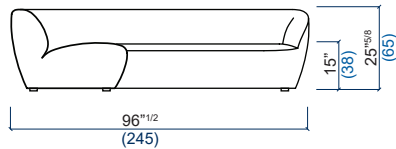
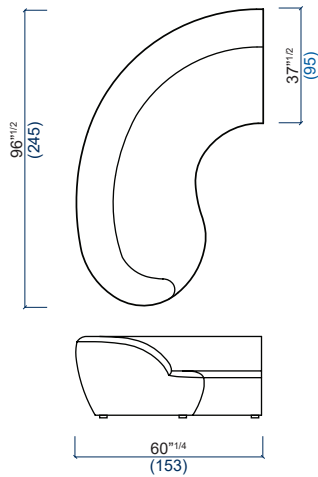

**66** Angle/Méridienne maxi droit  
Maxi Corner/Meridienne - Right  
Angulo/Meridienne maxi derecho

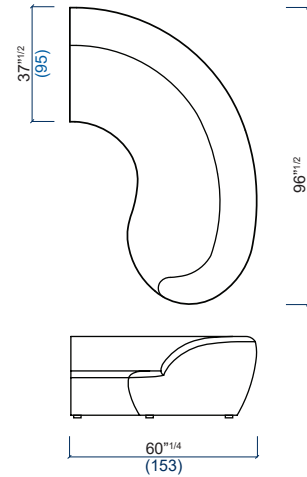

# EDITO ANGLE

design Sacha LAKIC

## COMPOSITIONS / COMPOSITIONS / COMPOSICIONES

38 + 62

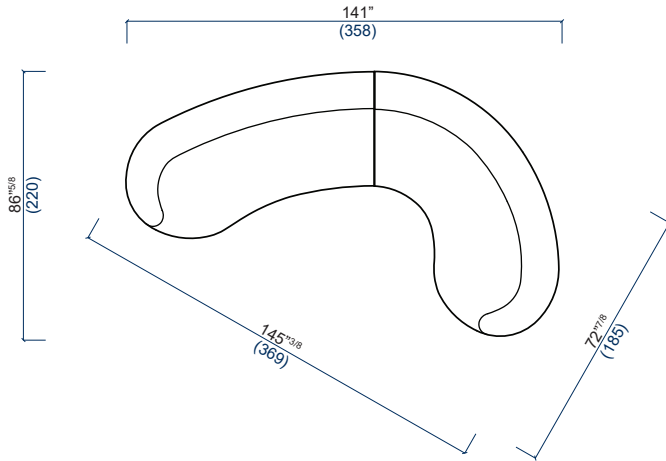

33 + 62

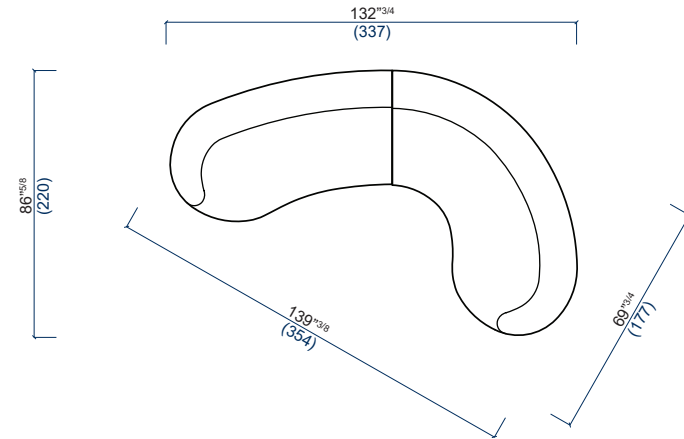

38 + 66

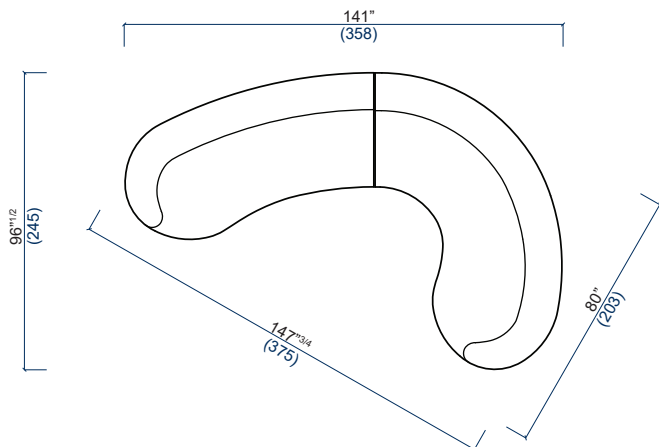

33 + 66

