

PRINCIPE

rochebobois
PARIS

design Studio ROCHE BOBOIS



PRINCIPE

design Studio ROCHE BOBOIS

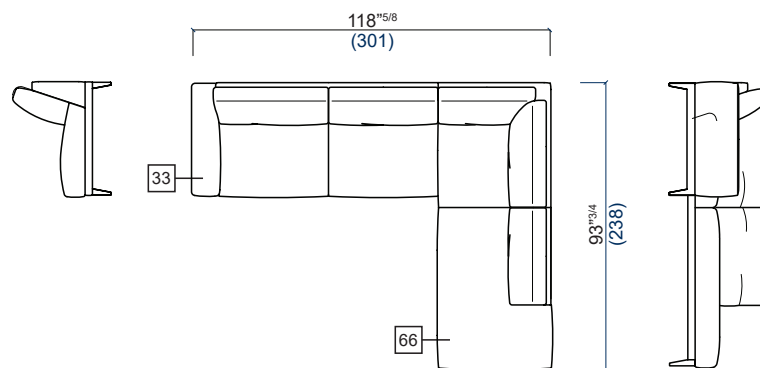

- 33** Bâtard 3 places gauche
3-seat 1-arm unit left
Batard 3 plazas izquierdo
- 66** Grand Angle/Méridienne droit
Large Corner/Meridienne - Right
Gran Angulo/Meridienne derecho

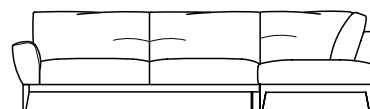

PRINCIPE

rochebobois
PARIS

design Studio ROCHE BOBOIS



FICHE TECHNIQUE / TECHNICAL SPECIFICATIONS / FICHA TECNICA:

Structure : Sapin massif, multiplis de pin et panneaux de particules

Suspension : Sangles élastiques HR

Garnissage assise : Mousse polyuréthane HR bi-densité 23-35 kg/m³ et ouate polyester

Garnissage dossier : Plumes d'oie et fibre polyester

Garnissage accoudoir : Mousse polyuréthane HR bi-densité 23-30 kg/m³, fibre polyester et plumes d'oie

Piètement : Métal finition Nickel Noir

Structure: Solid fir wood, pine plywood and engineered composite wood

Suspension: HR elastic straps

Seat cushion: HR bi-density polyurethane foam 23-35 kg/m³ and polyester batting

Back cushion: Goose feathers and polyester fibre

Armrest cushion: HR bi-density polyurethane foam 23-30 kg/m³, polyester fibre and goose feathers

Legs: Metal with Black Nickel finish

Estructura: Abeto macizo, multilaminado de pino y paneles de partículas

Suspensión: Cinchas elásticas HR

Interior asiento: Espuma poliuretano HR bi-densidad 23-35 kg/m³ y guata poliéster

Interior respaldo: Plumas de oca y fibra poliéster

Interior apoyabrazo: Espuma poliuretano HR bi-densidad 23-30 kg/m³, fibra poliéster y plumas de oca

Patatas: Metal acabado Niquel Negro

OBSERVATIONS / OBSERVATIONS / OBSERVACIONE:

- Fabrication Européenne
- Modèle réalisable dans tous les tissus de la collection Roche Bobois à l'exception des tissus Techno 2D, Techno 3D, Techno 4D, à motifs ou à rayures (avec raccords) et des velours de coton
- Modèle non réalisable en cuir

- Manufactured in Europe
- This model is available in all fabrics from the Roche Bobois collection, with the exception of Techno 2D, Techno 3D, Techno 4D, striped and patterned fabrics (with repeat) and cotton velvets
- This model is not available in leather

- Fabricación europea
- Modelo realizable en todas las telas de la colección Roche Bobois, excepto con las telas Techno 2D, Techno 3D, Techno 4D, las telas con motivos y rayadas (con racords) y los terciopelos de algodón
- Modelo no realizable en piel

OPTIONS / OPTIONAL / OPCIONES:

- Passepoil contrasté en similicuir, coloris au choix : Blanc, Gris clair, Gris Plomb, Taupe, Anthracite
- Têteière indépendante
- Contrasting piping in leather-like fabric, available in the following colours: Blanc, Gris clair, Gris Plomb, Taupe, Anthracite
- Independent headrest
- Ribete contrastado en símil de piel, colores a escoger: Blanc, Gris clair, Gris Plomb, Taupe, Anthracite
- Cabezal independiente

design Studio ROCHE BOBOIS

DIMENSIONS COMMUNES A TOUS LES ELEMENTS / SAME DIMENSIONS FOR ALL ELEMENTS / MEDIDAS COMUNES A TODOS LOS ELEMENTOS

Les dimensions reportées (profondeur et hauteur de l'élément, profondeur et hauteur de l'assise, largeur des accoudoirs) sont communes à tous les éléments.

The dimensions below (depth and height of the element, depth and height of the seat cushion, width of the armrests) are the same for all elements.

Las medidas mencionadas (profundidad y altura del elemento, profundidad y altura del asiento, ancho de los apoyabrazos), son comunes a todos los elementos.

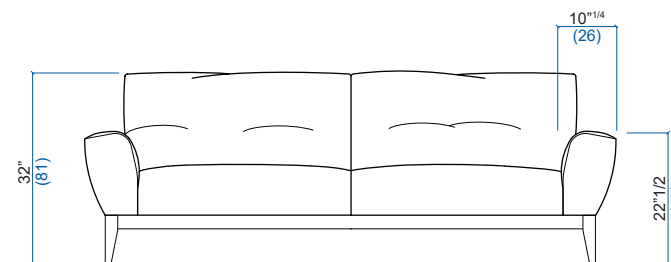
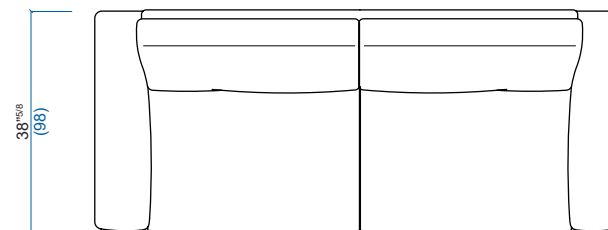
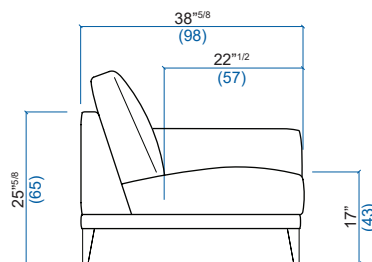

PRINCIPE

design Studio ROCHE BOBOIS

20 Canapé 2 places
2-seat sofa
Sofá 2 plazas

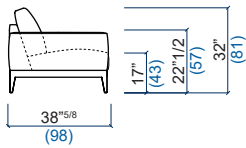
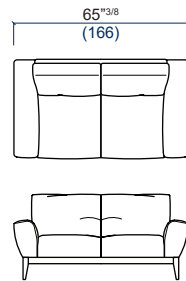

30 Canapé 3 places
3-seat sofa
Sofá 3 plazas

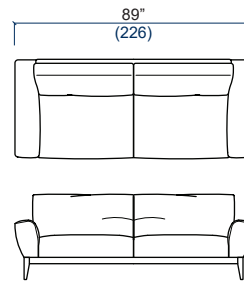

40 Pouf carré
Square ottoman
Puf cuadrado

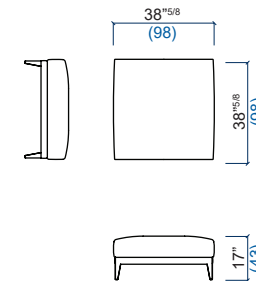

25 Canapé 2.5 places
2.5-seat sofa
Sofá 2.5 plazas

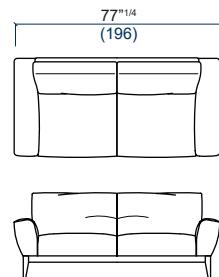

35 Canapé 3-4 places
3-4-seat sofa
Sofá 3-4 plazas

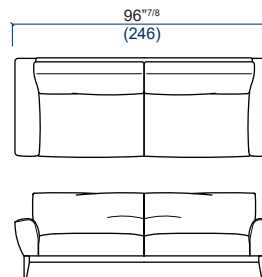

99 Tête indépendante
Independent headrest
Cabezal independiente

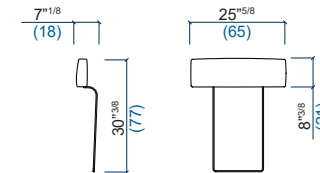

design Studio ROCHE BOBOIS

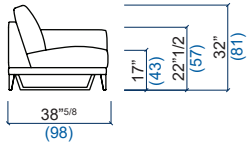

28 Bâtard 2 places gauche
2-seat 1-arm unit left armrest
Batard 2 plazas izquierdo

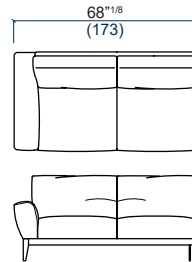

27 Bâtard 2 places droit
2-seat 1-arm unit right armrest
Batard 2 plazas derecho

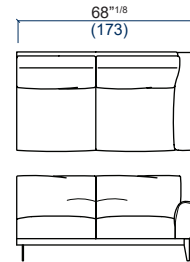

33 Bâtard 3 places gauche
3-seat 1-arm unit left armrest
Batard 3 plazas izquierdo

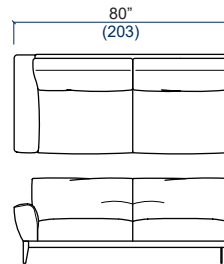

32 Bâtard 3 places droit
3-seat 1-arm unit right armrest
Batard 3 plazas derecho

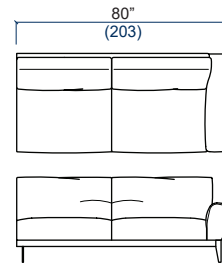

38 Grand Bâtard 3 places gauche
Large 3-seat 1-arm unit left armrest
Gran Batard 3 plazas izquierdo

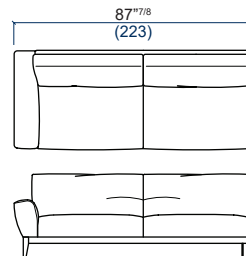

37 Grand Bâtard 3 places droit
Large 2-seat 1-arm unit right armrest
Gran Batard 2 plazas derecho

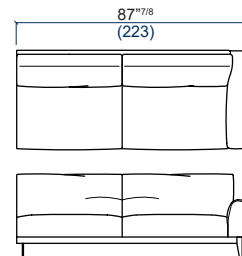

Tous BATARDS seront nécessairement associés, dans une composition, à un ANGLE/MERIDIENNE ou à un ANGLE CARRE

In a composition, all 1-ARM UNITS must be associated with a CORNER/MERIDIENNE or a SQUARE CORNER

Elementos BATARD utilizables únicamente en una composición con un ANGULO/MERIDIENNE o un ANGULO CUADRADO

PRINCIPE

design Studio ROCHE BOBOIS

Tous ANGLES/MERIDIENNE ou ANGLES
CARRES seront nécessairement associés, dans
une composition, à un BATARD

In a composition, all CORNER/MERIDIENNES or
SQUARE CORNERS must be associated with a
1-ARM UNIT

Elementos ANGULOS/MERIDIENNE o ANGULOS
CUADRADOS utilizables únicamente en una
composición con un BATARD

50 Angle carré
Square corner
Angulo cuadrado

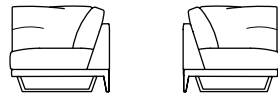
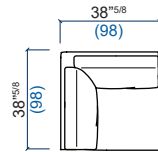

53 Petit Angle/Méridienne gauche
Small Corner/Meridienne - Left
Pequeño Angulo/Meridienne izquierdo

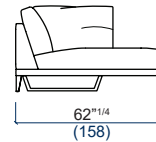
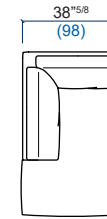

52 Petit Angle/Méridienne droit
Small Corner/Meridienne - Right
Pequeño Angulo/Meridienne derecho

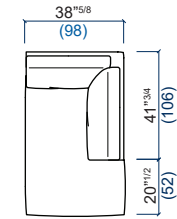

63 Angle/Méridienne gauche
Corner/Meridienne - Left
Angulo/Meridienne izquierdo

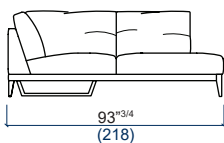
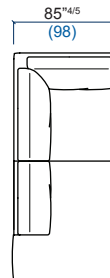

62 Angle/Méridienne droit
Corner/Meridienne - Right
Angulo/Meridienne derecho

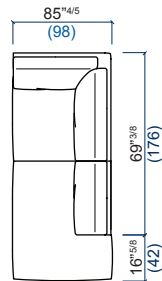

67 Grand Angle/Méridienne gauche
Large Corner/Meridienne - Left
Gran Angulo/Meridienne izquierdo

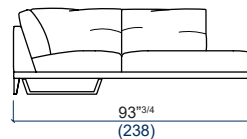
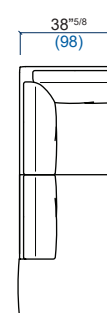

66 Grand Angle/Méridienne droit
Large Corner/Meridienne - Right
Gran Angulo/Meridienne derecho

