

SNOOKER

design : Philippe BOUIX



SNOOKER

design : Philippe BOUIX

rochebobo
PARIS



SNOOKER

rochebobois
PARIS

design : Philippe BOUIX



INFORMATIONS TECHNIQUES / TECHNICAL SPECIFICATIONS / CARACTERISTICAS TECNICAS:

Structure : Sapin massif et mutiplis de bouleau
Suspension : Ressorts sur sangles en jute
Garnissage assise : Mousse HR 40 kg/m³ et Ouate 100 gr/m²
Garnissage dossier : Mousse HR bi-densite 25 et 30 kg/m³ et ouate 100 gr/m²
Garnissage accoudoir : Mousse HR bi-densite 50 et 40 kg/m³, memory foam et ouate 100 gr/m²
Piétement : Métal finition Canon de fusil

Structure: Solid fir wood and birch plywood
Suspension: Springs on jute straps
Seat cushions: HR foam 40kg/m³ and batting 100 gr/m²
Back cushions: Bi-density HR foam 25 and 30 kg/m³ and batting 100 gr/m²
Armrest: Bi-density HR foam 50 and 40 kg/m³, memory foam and batting 100 gr/m²
Base: Metal with Canon de Fusil finish

Estructura : Abeto macizo y multilaminado de álamo
Suspensión: Muelles sobre cinchas de yute
Relleno asiento: Espuma HR 40 kg/m³ y guata 100 gr/m²
Relleno respaldo: Espuma HR bi-densidad 25 y 30 kg/m³ y guata 100 gr/m²
Relleno apoyabrazos: Espuma HR bi-densidad 50 y 40 kg/m³, espuma memory y guata 100 gr/m²
Patatas: Metal acabado Cañon de fusil

OBSERVATIONS / OBSERVATIONS / OBSERVACIONES:

- Fabrication européenne
- Coutures invisibles
- Fabrication traditionnelle (suspension ressorts sur sangles en jute)
- Modèle réalisable dans de nombreuses qualités de cuirs

- Manufactured in Europe
- Invisible stitching
- Traditional manufacturing (springs on jute straps suspensions)
- Model available in many leathers

- Fabricacion europea
- Costura invisible
- Fabricación tradicional (suspensión muelles sobre cinchas en yute)
- Modelo realizado en numerosas calidades de pieles

OPTIONS / OPTIONS / OPCIONES:

- Têteière
- Headrest
- Cabezal

SNOOKER

design : Philippe BOUIX

CANAPE 3-4 PLACES
3/4-SEAT SOFA
SOFA 3-4 PLAZAS

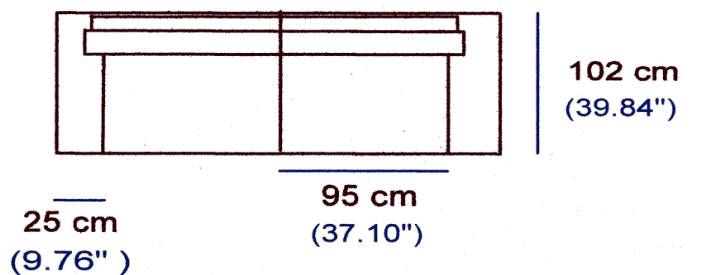

GRAND CANAPE 3 PLACES
LARGE 3-SEAT SOFA
GRAN SOFA 3 PLAZAS

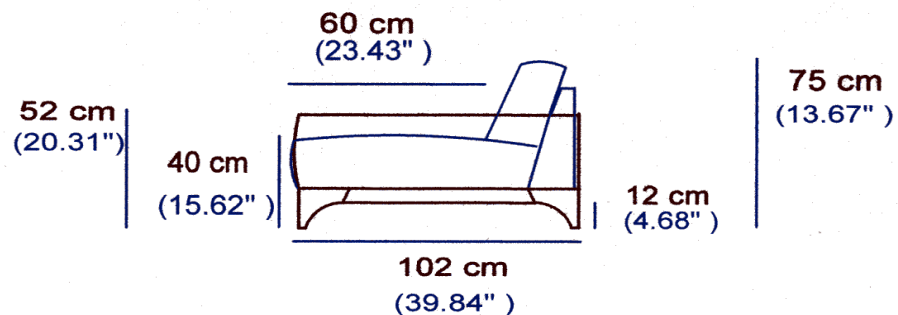
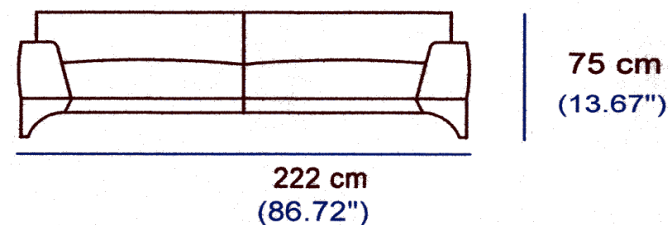
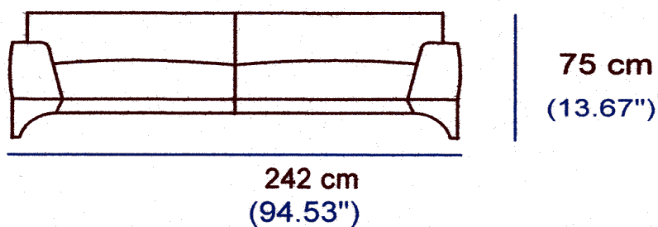
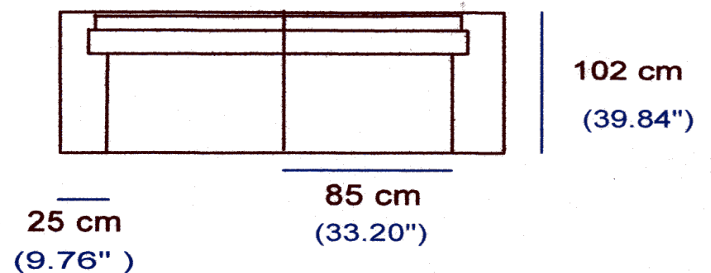

SNOOKER

design : Philippe BOUIX

CANAPE 3 PLACES
3-SEAT SOFA
SOFA 3 PLAZAS

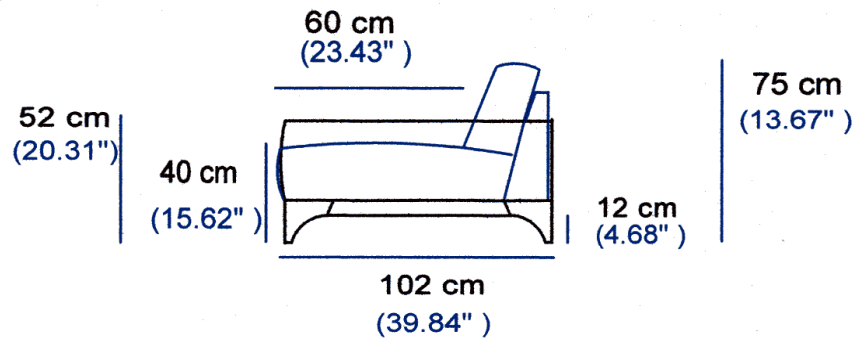
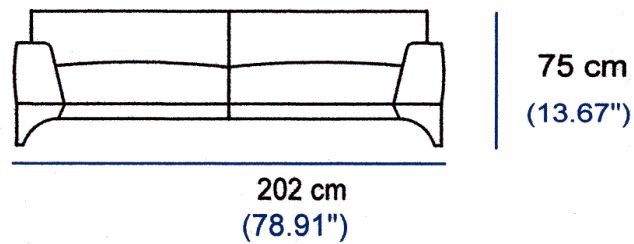
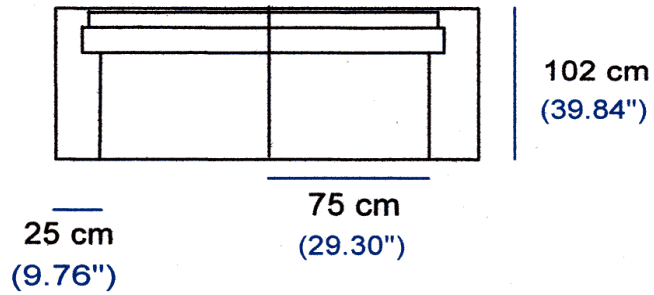

CANAPE 2.5 PLACES
2.5-SEAT SOFA
SOFA 2.5 PLAZAS

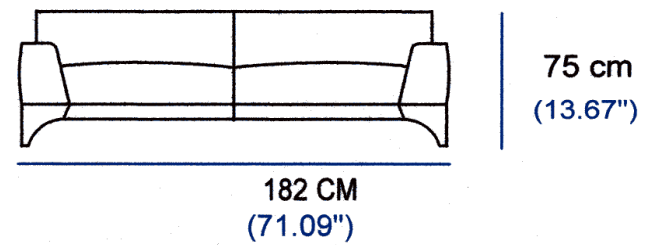
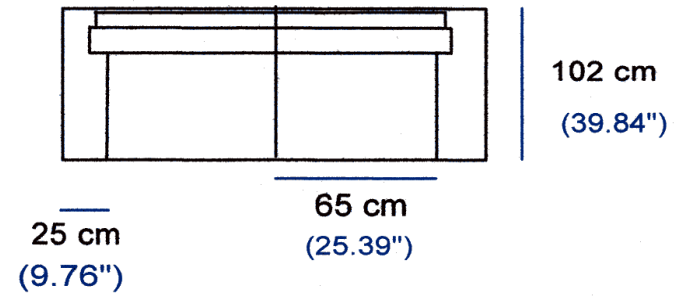

SNOOKER

design : Philippe BOUIX

FAUTEUIL
ARMCHAIR
SILLON

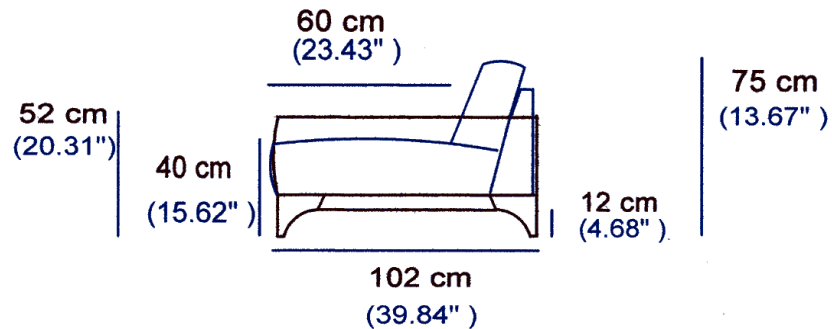
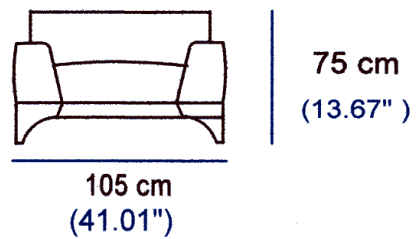
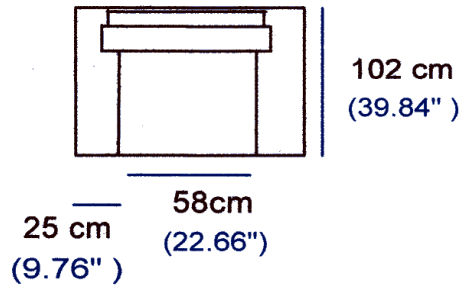

POUF
OTTOMAN
POUF

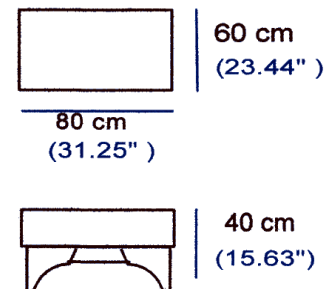

TETIERE
HEADREST
CABEZAL

