

CALANQUE

design Giorgio SORESSI

rochebobois
PARIS



CALANQUE

rochebobois
PARIS

design Giorgio SORESSI



COMPOSITION D'ANGLE (L.345/268 x H.80 x P.115 cm)

TERMINAL GAUCHE L.230 cm
GRANDE MERIDIENNE DROITE L.268 cm

CORNER COMPOSITION (135.8"/105.5"W x 31.5"H x45.3"D)

END UNIT LEFT 90,6"
LARGE MERIDIENNE RIGHT 105,5"

COMPOSICION DE ANGULO (L.345/268 x H.80 x P.115 cm)

TERMINAL IZQUIERDO L.230 cm
GRAN MERIDIENNE DERECHA L.268 cm

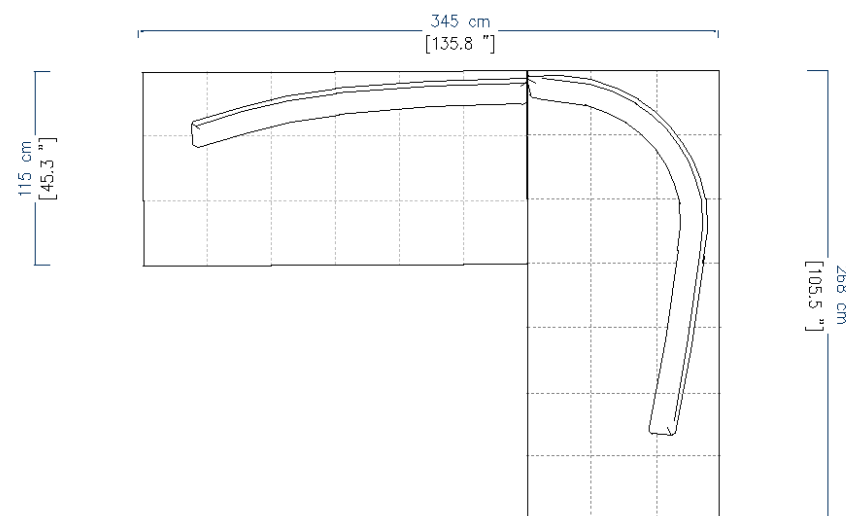

CALANQUE

rochebobois
PARIS

design Giorgio SORESSI

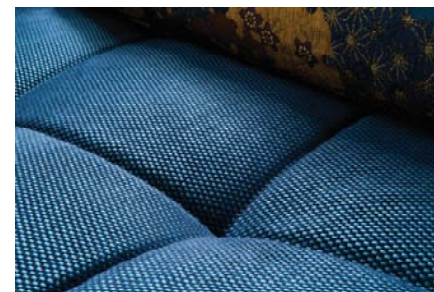

INFORMATIONS TECHNIQUES / TECHNICAL SPECIFICATIONS / CARACTERISTICAS TECNICAS

Structure : Métal
Suspension : Sangles élastiques
Garnissage assise monobloc : Mousse tri-densité 25-30-40 kg/m³ et fibres
Garnissage dossier : Plumes et fibres
Garnissage coussins déco : Plumes d'oie et canard
Piétement : Hêtre massif

Structure: Metal
Suspension: Elastic straps
Monobloc seat cushion: Tri-density foam 25-30-40 kg/m³ and fibres
Back cushions: Feathers and fibres
Deco cushions: Goose and duck feathers
Base: Solid beech

Estructura: Metal
Suspensión: Cinchas elásticas
Interior asiento monobloc: Espuma tri-densidad 25-30-40 kg/m³ y fibras
Interior respaldo: Plumas y fibras
Interior cojines de decoración: Plumas de oca y pato
Patas: Haya maciza

OBSERVATIONS / OBSERVATIONS / OBSERVACIONES:

- Fabrication Européenne
- Modèle réalisable dans tous les tissus de la collection Roche Bobois
- Manufactured in Europe
- Model available in all fabrics from the Roche Bobois collection
- Fabricación europea
- Modelo realizable en todas telas de la colección Roche Bobois

OPTIONS / OPTIONAL / OPCIONES :

- Piétement disponible en 3 versions: Métal chromé et Hêtre massif, Hêtre massif et invisible en PVC
- Legs available in 3 versions: Chrome-plated metal and solid beech, solid beech and invisible in PVC
- Patas disponibles en 3 versiones: Metal cromado y Haya maciza, Haya maciza e invisibles en PVC

CALANQUE

design Giorgio SORESSI

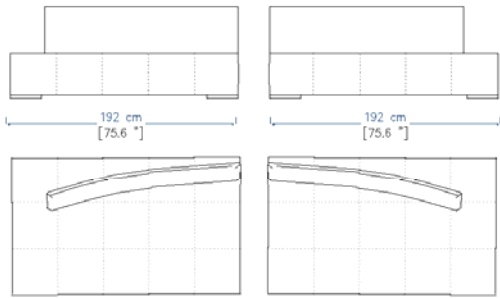
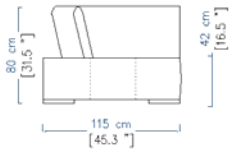

TERMINAL GAUCHE
END UNIT LEFT
TERMINAL IZQUIERDO

TERMINAL DROIT
END UNIT RIGHT
TERMINAL DERECHO

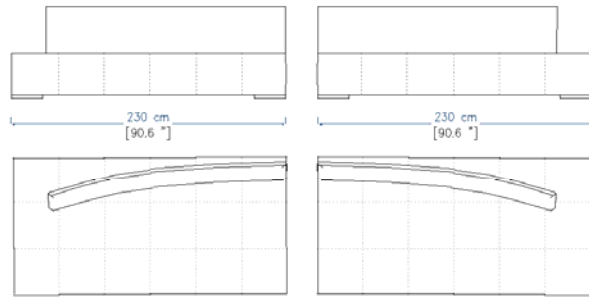

TERMINAL GAUCHE
END UNIT LEFT
TERMINAL IZQUIERDO

TERMINAL DROIT
END UNIT RIGHT
TERMINAL DERECHO

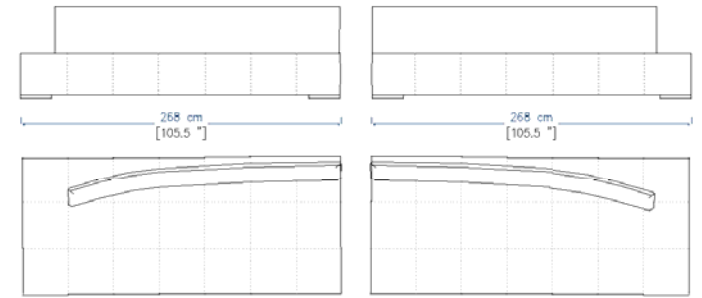

GRAND TERMINAL GAUCHE
LARGE END UNIT LEFT
GRAN TERMINAL IZQUIERDO

GRAND TERMINAL DROIT
LARGE END UNIT RIGHT
GRAN TERMINAL DERECHO

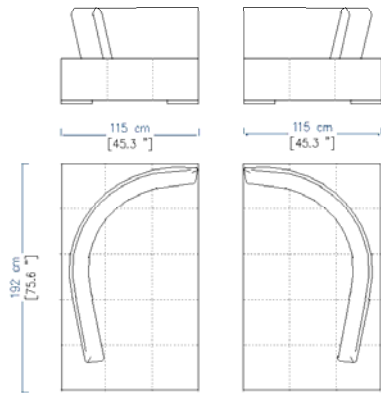
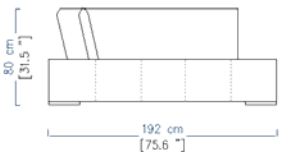

MERIDIENNE GAUCHE
MERIDIENNE LEFT
MERIDIENNE IZQUIERDA

MERIDIENNE DROITE
MERIDIENNE RIGHT
MERIDIENNE DERECHA

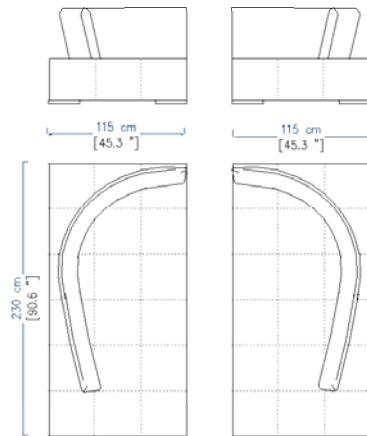

MERIDIENNE GAUCHE
MERIDIENNE LEFT
MERIDIENNE IZQUIERDA

MERIDIENNE DROITE
MERIDIENNE RIGHT
MERIDIENNE DERECHA

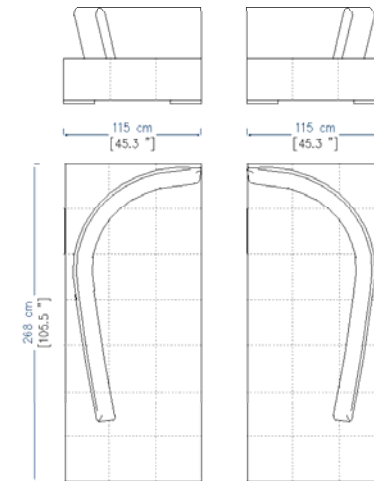

GRANDE MERIDIENNE GAUCHE
LARGE MERIDIENNE LEFT
GRAN MERIDIENNE IZQUIERDA

GRANDE MERIDIENNE DROITE
LARGE MERIDIENNE RIGHT
GRAN MERIDIENNE DERECHA

CALANQUE

design Giorgio SORESSI

rochebobois
PARIS

