

**Silvia**  
**Paolo Tilche, 1960**  
**Archivio Storico Bonacina 1889**

**Poltrona**

**Materiali:**

STRUTTURA: poltrona in giunco, base in Manila e struttura in Malacca con armatura in canna d'India e legature in corteccia di giunco, qualità extra superiore. Piedini in termoplastica.

+info:

<http://www.depadova.com/materials.pdf>

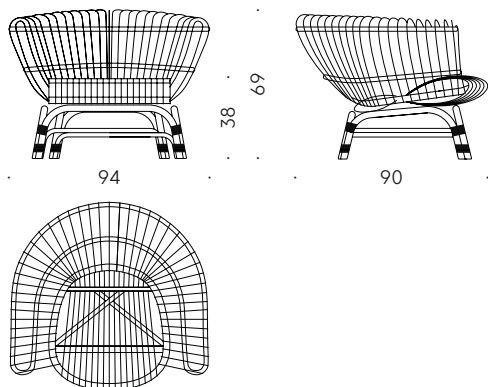

**Silvia**  
**Paolo Tilche, 1960**  
**Archivio Storico Bonacina 1889**

**Armchair**

**Materials:**

FRAME: seat in rattan, base in Manila and frame in Malacca with armour in Indian cane and bindings in extra-quality rattan skin threads. Thermoplastic feet.

+info:

<http://www.depadova.com/materials.pdf>

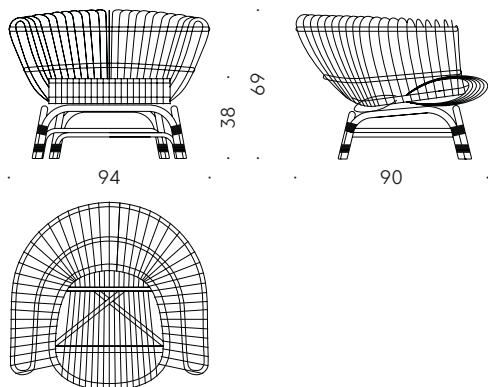

**Silvia**  
**Paolo Tilche, 1960**  
**Archivio Storico Bonacina 1889**

**Fauteuil**

**Matériaux:**

STRUCTURE : fauteuil en jonc, base en Manila et structure en Malacca avec armure en canne d'Inde et liens en écorce de jonc, qualité extra supérieur. Pieds en thermoplastique.

+info:

<http://www.depadova.com/materials.pdf>

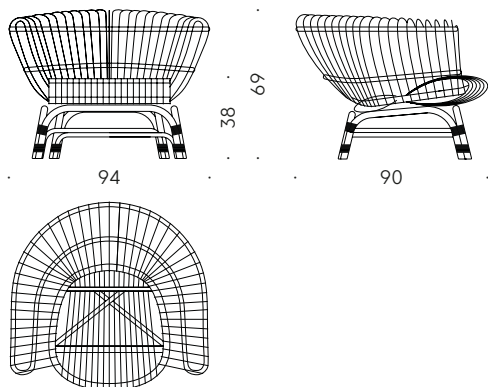

**Silvia**  
**Paolo Tilche, 1960**  
**Archivio Storico Bonacina 1889**

**Sessel**

**Materialien:**

GESTELL: Sessel aus Rattan, Untergestell in Manila und Gestell in Malacca mit Verstärkung aus Schilfrohr mit Bindungen in Binsenrinde, extra hohe Qualität. Thermoplast-FüÙe.

+info:

<http://www.depadova.com/materials.pdf>

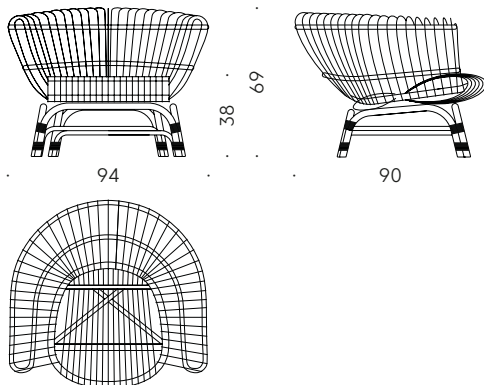

# Silvia Paolo Tilche, 1960 Archivio Storico Bonacina 1889



## Butaca

### Materiales:

ESTRUCTURA: butaca de ratán, base de Manila y estructura de Malaca con armazón de caña de India y ataduras de corteza de ratán, calidad extra superior, acabado con barniz acrílico transparente. Pies de termoplástico.

+info:

<http://www.depadova.com/materials.pdf>

