

# GRAMERCY LOW TABLE

MAURO LIPPARINI



**MisuraEmme®**

Harmonious design and soft lines with clear influence drawn from the world of sculpture, coming together to create a piece with absolute aesthetic value. Different dimensions and materials make for a sophisticated item for the living room. The legs, a triptych easel, follow the same drawing of **Gramercy** table.

## TYPE / SMALL TABLES

### TECHNICAL DESCRIPTION

*Series of table with base hand in crafted. Various are the modification of the tipology, dimensions and finishing in a game of combination: wood and varnish or all lacquer tone on tone or in contrast; the legs, a triptych easel, follow the same drawing of **Gramercy** table.*

*The plan is supported by spacers in brushed steel.*

**Finishes** wooden top with shaped undertop:

- veneered top with undertop in matt lacquered
- veneered top with undertop in glossy laquered
- top and undertop in matt lacquered
- top and undertop in glossy lacquered
- top in marble th. 20mm (6/8").

*The high and low Sidetable is also available with top in transparent glass th.8mm (3/8")*



## DESIGNER

MAURO LIPPARINI

**Mauro Lipparini** earned a degree in Architecture in 1980 from Università degli Studi of Florence, where he also worked as a professor. He won the international design contests Young & Designer Milan (1987) and International Du Pont Award Köln (Germany, 1988 and 1989). Lipparini's intense activity in the field of industrial design covers office and home furniture, the textile industry and other products created for many companies in Europe and Japan. In architecture and interior design, Lipparini has concentrated mainly on private and public housing, on showrooms, retail sales outlets and exposition installations. Furthermore, Lipparini also designs and realizes advanced corporate identity image systems that range from graphics to editorial services to production. Lipparini's style is based on the essential shapes and the clear and decisive lines that are characteristic of natural minimalism. His creations are imbued with a joyful spirit and with an elating sense of aesthetic pleasure and creativity. Thanks to his free use of color, organic weave patterns and original visual ideas, Lipparini amplifies the palette of minimalism, conveying the spontaneity and power of this aesthetic style and projecting it towards a new era of great maturity and wellbeing.



**MisuraEmme®**

# TOP FINISHINGS

## MATT LACQUERED COLOURS



## HIGH GLOSS LACQUERED COLORS





TRANSPARENT GLASS

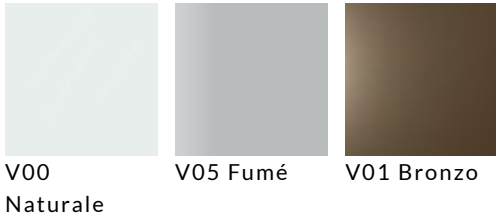

MARBLES



MATT VENEERS



# UNDERTOP FINISHINGS

## MATT LACQUERED COLOURS



## HIGH GLOSS LACQUERED COLORS





L98 Oliva



L8S Giallo



L9B Senape



L94 Marsala



L81 Fuoco



L95 Ruggine



L9H Petrolio



L9E Deep  
Blu

# BASE FINISHINGS

## MATT VENEERS

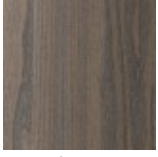

53 Olmo  
grey

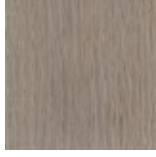

50 Rovere  
cenere



52 Rovere  
fumé

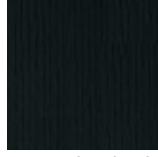

51 Oak Black



# DIMENSIONS

## Wood top

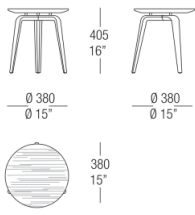

## Wood top

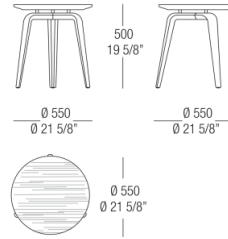

## Matt lacquer / glossy lacquer top

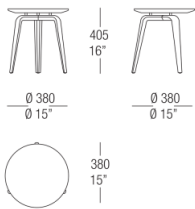

## Matt lacquer / glossy lacquer top

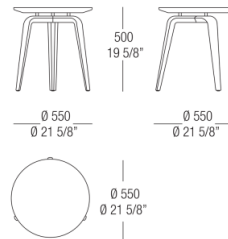

## Marble top

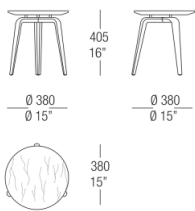

## Marble top

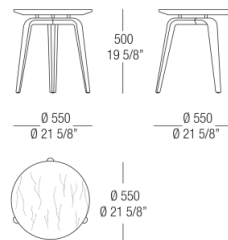

Glass top

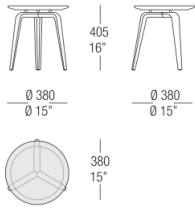

Glass top

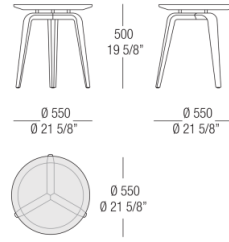

Wood top

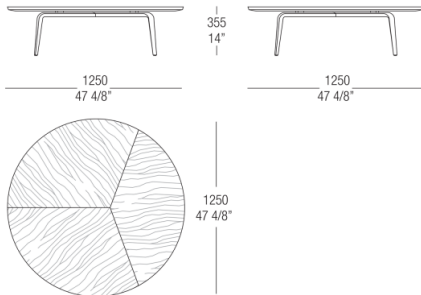

Wood top

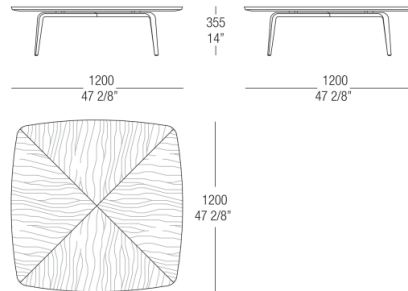

Wood top

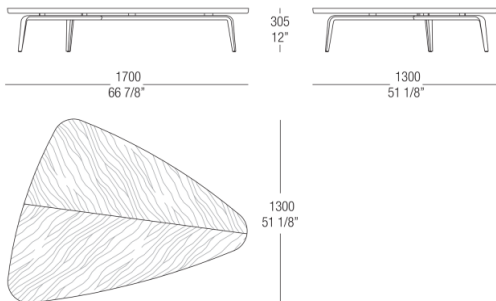

Matt lacquer / glossy lacquer top

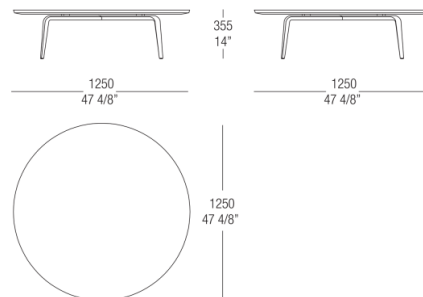

Matt lacquer / glossy lacquer top

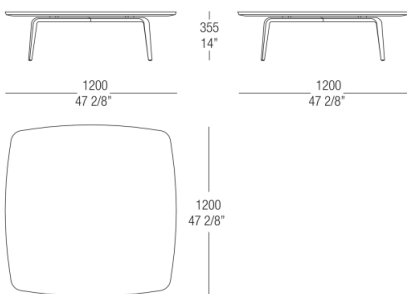

Matt lacquer / glossy lacquer top

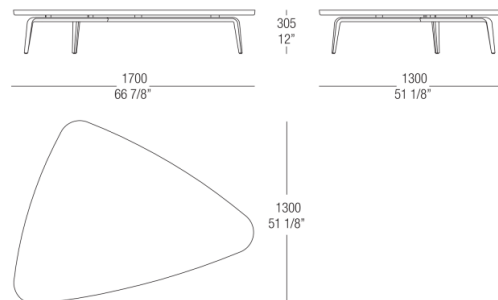

Marble top

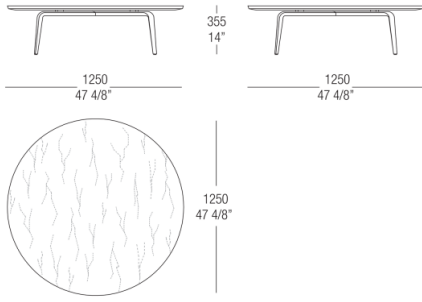

Marble top

