

## VERNER - VERNER DOUBLE FACE 2019

- Per la composizione dei moduli, assicurarsi di inserire la spalla di finitura a ogni elemento laterale (destra e sinistra).
- Il modulo 60 con vano aperto, nella versione elemento laterale, non necessita di spalla di finitura.
- Il modulo 60 con vano aperto non può essere configurato di fianco a un altro elemento uguale per questioni tecniche.
- Il modulo 60 con vano aperto e il modulo ANGOLO, nelle versioni VERNER e VERNER DOUBLE FACE hanno sempre lo schienale di finitura.
- Il modulo 60 con vano aperto, il modulo 60 con anta e il modulo ANGOLO non si possono utilizzare come elementi singoli.
- Il basamento laterale deve essere configurato solo sugli elementi laterali. Invece il basamento centrale deve essere posizionato in corrispondenza dell'unione degli elementi.
- Nella configurazione a muro (VERNER) il basamento deve essere regolato per poter avere la composizione a ridosso della parete.
- I top nelle composizioni della stessa finitura, impiallacciato rovere e lacca opaca/lucida, saranno interi per una lunghezza max di mt. 3.
- Il modulo 60 con vano aperto e il modulo ANGOLO, nelle versioni VERNER e VERNER DOUBLE FACE hanno sempre il top dedicato.

- For the composition of the modules, make sure to insert the finishing shoulder on each side element (right and left).
- The open unit 60 modular does not need a finishing shoulder for the side element version.
- The open unit 60 modular cannot be configured next to another equal element due to technical issues.
- The open unit 60 modular and ANGLE one, in VERNER and VERNER DOUBLE FACE versions always have a finishing backrest.
- The open unit 60 modular, the open unit 60 modular with door and ANGLE one cannot be used as single elements.
- The side base must be configured only on the side elements. Instead the central base must be positioned at the union of the elements.
- In the wall configuration (VERNER) the base must be adjusted in order to have the composition close to the wall.
- The tops in oak veneer and matt / glossy lacquer, with compositions of the same finish, will be whole for a maximum length of mt. 3.
- The open unit 60 modular and ANGLE one, in VERNER and VERNER DOUBLE FACE versions always have the dedicated top.

- Achten Sie bei der Zusammenstellung der Module darauf, die Abschlusschulter an jedem Seitenelement (rechts und links) einzufügen.
- Das Modul 60 offen benötigt in der Seitenelementversion keine Abschlusschulter.
- Das Modul 60 offen kann aus technischen Gründen nicht neben einem anderen gleichen Element konfiguriert werden.
- Das Modul 60 offen und das ECK-MODUL, in den Versionen VERNER und VERNER DOUBLE FACE, haben immer eine verarbeitete Rückenlehne.
- Das Modul 60 offen, das Modul 60 mit Tür und ECK-MODUL können nicht als Einzelelemente verwendet werden.
- Das seitliche Gestell kann nur an den Seitenelementen konfiguriert werden. Das Mittelgestell muss dagegen an der Vereinigung der Elemente positioniert werden.
- In der Wandkonfiguration (VERNER) muss das Gestell so eingestellt werden, dass die Zusammensetzung nahe an der Wand liegt.
- Bei Kompositionen in derselben Ausführung (nur aus Eichenfurnier und Lack matt/Hochglanz), werden die Platten durchgehend sein, mit einer maximalen Länge von 3 mt.
- Das Modul 60 offen und das ECK-MODUL, in den Versionen VERNER und VERNER DOUBLE FACE haben immer ihre eigene Oberfläche.

- En assemblant les éléments modulaires, merci de bien insérer le panneau latéral fini à chaque élément latéral (droit et gauche).
- L'élément 60 ouvert, lorsqu'il est utilisé comme élément latéral, n'a pas besoin du panneau latéral fini.
- Pour des raisons techniques, on ne peut pas utiliser des éléments 60 ouverts l'un à côté de l'autre.
- L'élément 60 ouvert et l'élément ANGLE, pour les versions VERNER et VERNER DOUBLE FACE, ont toujours le panneau du dossier fini.
- L'élément 60 ouvert, l'élément 60 avec porte et l'élément ANGLE ne peuvent pas être utilisés tous seuls.
- La base latérale doit être utilisée seulement sur les éléments latéraux. En revanche, la base centrale doit être placée en correspondance de la jonction des éléments.
- Pour la version du meuble au mur (VERNER), la base doit être réglée, afin d'avoir le meuble appuyé au mur.
- Les plateaux des compositions jusqu'à 3 mètres de longueur maximum et dans la même finition, soit en chêne teinté soit en laque mate/brillante, seront entiers.
- En revanche, l'élément 60 ouvert et l'élément ANGLE, pour les versions VERNER et VERNER DOUBLE FACE seront toujours réalisés avec plateau séparé.

- Durante la composición de los módulos, asegurarse de insertar correctamente el panel lateral acabado a cada elemento lateral (derecha e izquierda).
- El módulo 60 abierto, cuando utilizado como módulo lateral, no necesita del panel lateral acabado.
- Por razones técnicas, no es posible utilizar los módulos 60 juntos.
- El módulo 60 abierto y el elemento ÁNGULO, para la versión VERNER y VERNER DOUBLE FACE, tienen siempre el panel del respaldo acabado.
- No es posible utilizar el módulo 60 abierto, el módulo 60 con puerta y el elemento ÁNGULO sueltos.
- Es posible utilizar la base lateral solamente con los elementos laterales. En cambio, hay que poner la base central bajo del punto de unión de los módulos.
- En la versión del mueble a pared (VERNER), hay que ajustar la base, para que el mueble resulte contra el muro.
- Los paneles de las composiciones hasta 3 metros de largo y con el mismo acabado, tanto en roble enchapado como en lacado brillo/mate, van a ser una pieza única.
- El módulo 60 abierto y el elemento ÁNGULO, para la versión VERNER y VERNER DOUBLE FACE, van a ser realizados siempre con panel separado.

esempio di composizione con vano giorno posto centralmente  
*example of composition with day room centrally located*

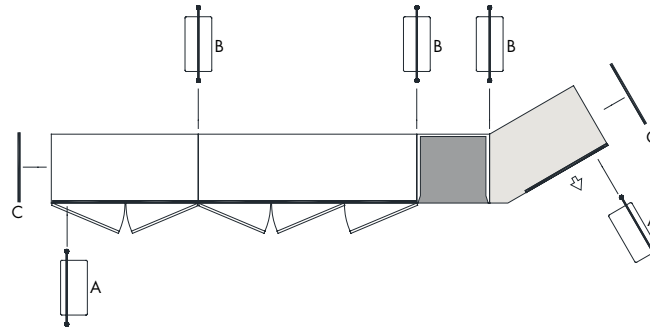
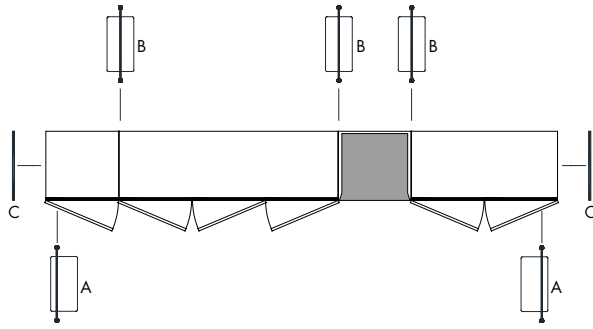

A - basamento laterale  
 conteggiare sempre N° 2  
 basamenti laterali

A - side stand  
 always count N° 2  
 side bases

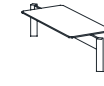

B - basamento centrale  
 conteggiare N° basamenti  
 centrali tanti quante  
 sono le "giunture" della  
 composizione

B - central basement  
 counting as many central  
 bases as there are "joints"  
 of the composition

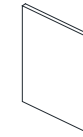

C - spalla  
 conteggiare N° 2  
 spalle di finitura

C - shoulder  
 count N° 2  
 finishing shoulders

esempio di composizione con n° 1 vano giorno posto lateralmente  
*example of composition with n° 1 day room placed laterally*

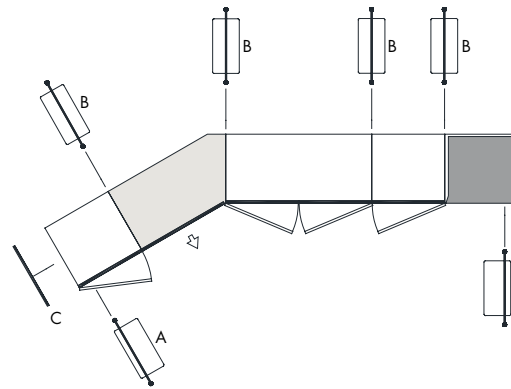
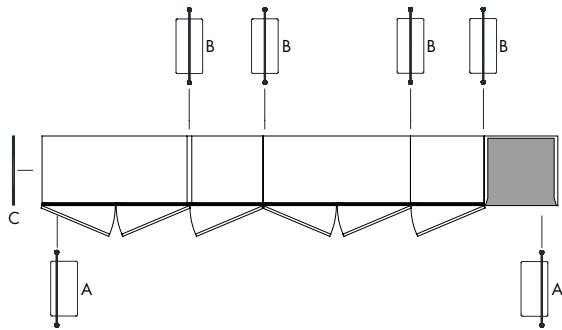

A - basamento laterale  
 conteggiare sempre N° 2  
 basamenti laterali

A - side stand  
 always count N° 2  
 side bases



B - basamento centrale  
 conteggiare N° basamenti  
 centrali tanti quante  
 sono le "giunture" della  
 composizione

B - central basement  
 counting as many central  
 bases as there are "joints"  
 of the composition

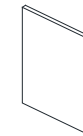

C - spalla  
 conteggiare N° 1  
 spalle di finitura

C - shoulder  
 count N° 1  
 finishing shoulders

esempio di composizione con n° 2 vani giorno posti lateralmente  
*example of composition with n° 2 day rooms placed laterally*

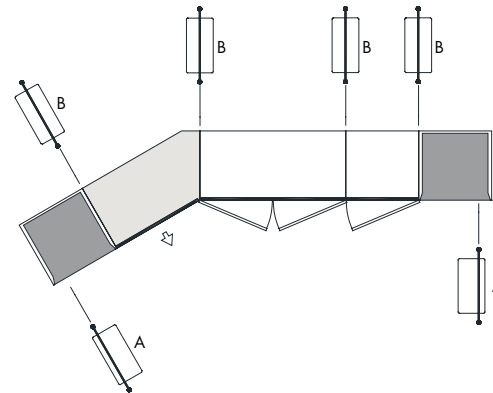
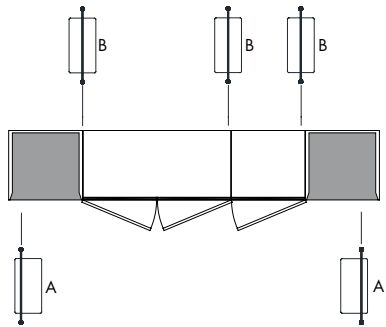

A - basamento laterale  
 conteggiare sempre N° 2  
 basamenti laterali

A - side stand  
 always count N° 2  
 side bases



B - basamento centrale  
 conteggiare N° basamenti  
 centrali tanti quante  
 sono le "giunture" della  
 composizione

B - central basement  
 counting as many central  
 bases as there are "joints"  
 of the composition

NESSUNA  
 spalla di finitura

NONE  
 shoulder  
 finishing

- contenitori modulari componibili:  
 modulo 60 con vano aperto  
 modulo 120 con due ante  
 modulo 180 con tre ante  
 modulo CORNER con cassettone
- finiture esterne:  
 impiallacciatura rovere tinto (interno rovere tinto)  
 lacca opaca o lucida (interno lacca opaca)  
 rivestimento ottone bronzato o acciaio platinato  
 con lacca opaca o lucida (interno lacca opaca)
- basamento regolabile in metallo  
 varnished opaco black
- accessori interni optional
- ripiano
- cassetiera

finiture: vedi campionario

attenzione: per la realizzazione di composizioni allegare all'ordine un disegno imballo obbligatorio in gabbia

- modular storage units:  
 unit 60 with open compartment  
 unit 120 with two doors  
 unit 180 with three doors  
 CORNER unit with drawer
- external finishes:  
 stained oak veneer (internal frame in stained oak)  
 matt or glossy lacquer (internal frame in matt lacquer)  
 coated in bronzed brass or platinum steel with matt or glossy lacquer (internal frame in matt lacquer)
- adjustable metal base  
 black matt varnished
- optional inner accessories
- shelf
- chest of drawers

finishes: see sample box

attention: for compositions, always attach sketches of configurations to orders  
 compulsory packing in wooden cage

- modulare Elemente:  
 Modul 60 offen  
 Modul 60 mit einer Tür  
 Modul 120 mit zwei Türen  
 Modul 180 mit drei Türen  
 Modul CORNER mit Schublade
- Außen Ausführungen:  
 Eiche furniert gebeizt (innen Eiche gebeizt)  
 matt oder Hochglanz lackiert (innen Lack matt)  
 messing bronziert oder platinum steel mit matt oder Hochglanz lackiert (innen Lack matt)
- verstellbaren Metall Gestell  
 black varnished
- Zusätzliche Innenausstattung
- Fachboden
- Schubladenkasten

Ausführungen: siehe Musterbox

Vorsicht: bei Kompositionen fügen Sie der Bestellung eine Zeichnung bei  
 Obligatorische Verpackung in Holzkaiste

- meubles de rangement modulaires:  
 module 60 avec niche ouverte  
 module 60 avec une porte  
 module 120 avec deux portes  
 module 180 avec trois portes  
 module CORNER avec grand tiroir
- finitions pour l'extérieur:  
 placage de chêne teinté (intérieur chêne teinté)  
 laque mate ou brillante (intérieur en laque mate)  
 couverture en laiton bronzé ou platinum steel avec laque mate ou brillante (intérieur en laque mate)
- base en métal réglable  
 verni couleur black
- optionnel accessoires pour l'intérieur
- étagère
- tiroirs

finitions: voir nos échantillons

attention: pour des compositions modulaires, merci de joindre à la commande le schéma correspondant  
 emballage en cage en bois obligatoire

- cajas de almacenamiento modulares:  
 módulo 60 con vano abierto  
 módulo 60 con una puerta  
 módulo 120 con dos puertas  
 módulo 180 con tres puertas  
 módulo CORNER con cajonera
- acabados exteriores:  
 enchapado en roble teñido  
 lacado mate o brillo (interior lacado mate)  
 revestimiento latón bronceado o platinum steel  
 con lacado mate o brillo (interior lacado mate)
- base en metal regulable  
 barnizada black
- opcionales accesorios interiores
- estante
- cajonera

acabados: vease el muestrario

atención: para composiciones adjuntar el dibujo a la orden  
 embalaje en jaula de madera obligatorio

## contenitore aperto - open storage unit 60

elemento  
 element

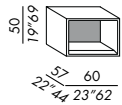

basamento laterale  
 side base

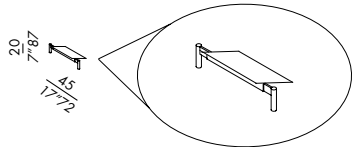

basamento centrale  
 central base

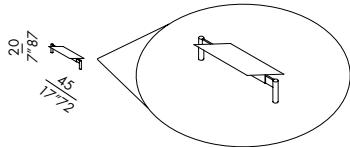

metallo verniciato nero  
 black varnished metal

479

**contenitore - storage unit 60**

elemento  
element

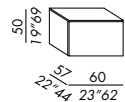

anta sx - left door



versione ottone bronzato o acciaio platinato  
bronzed brass or platinum plated steel

spalla  
side panel



basamento laterale  
side base

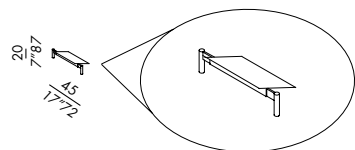

basamento centrale  
central base

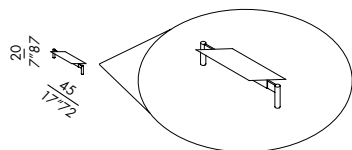

options:

ripiano - shelf  
60

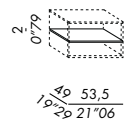

cassettiera - chest of drawers  
60

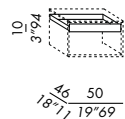

**contenitore - storage unit 120**

elemento  
element

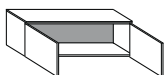
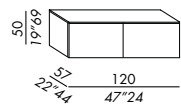

spalla  
side panel

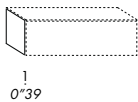

basamento laterale  
side base

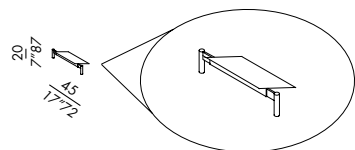

basamento centrale  
central base

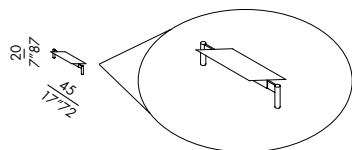

options:

ripiano - shelf  
120

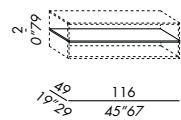

**contenitore - storage unit 180**

elemento  
element

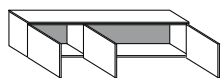
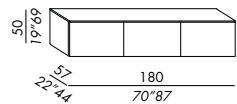

vano 60 sx - left compartment 60



versione ottone bronzato o acciaio platinato  
bronzed brass or platinum plated steel

spalla  
side panel

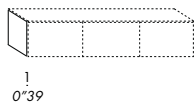

basamento laterale  
side base

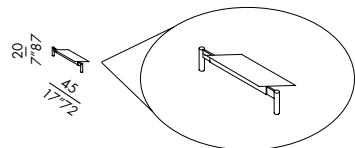

basamento centrale  
central base

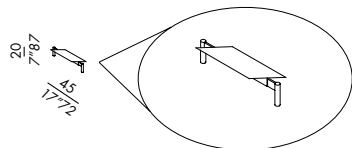

options:

ripiano - shelf  
60 / 120

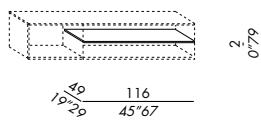
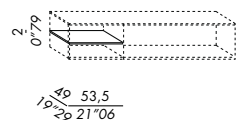

cassettiera - chest of drawers  
60

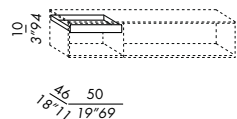

**contenitore ANGOLARE CHIUSO - storage unit CLOSED CORNER**

elemento  
element

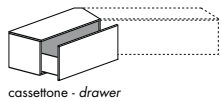
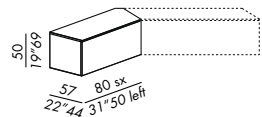

spalla  
side panel

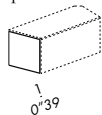

basamento laterale  
side base

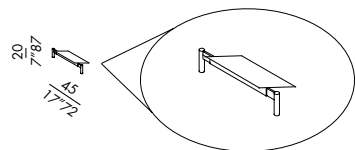

basamento centrale  
central base

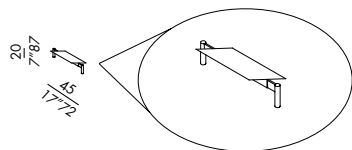

**contenitore ANGOLARE APERTO - storage unit OPEN CORNER**

elemento  
element

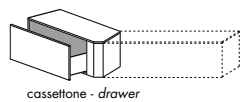
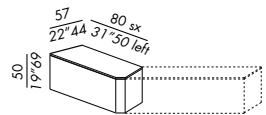

spalla  
side panel

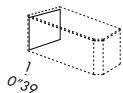

basamento laterale  
side base

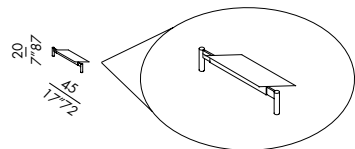

basamento centrale  
central base

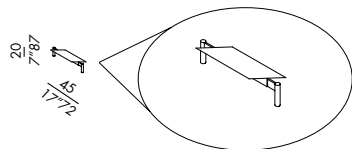



## VERNER - VERNER DOUBLE FACE 2019

- Per la composizione dei moduli, assicurarsi di inserire la spalla di finitura a ogni elemento laterale (destra e sinistra).
- Il modulo 60 con vano aperto, nella versione elemento laterale, non necessita di spalla di finitura.
- Il modulo 60 con vano aperto non può essere configurato di fianco a un altro elemento uguale per questioni tecniche.
- Il modulo 60 con vano aperto e il modulo ANGOLO, nelle versioni VERNER e VERNER DOUBLE FACE hanno sempre lo schienale di finitura.
- Il modulo 60 con vano aperto, il modulo 60 con anta e il modulo ANGOLO non si possono utilizzare come elementi singoli.
- Il basamento laterale deve essere configurato solo sugli elementi laterali. Invece il basamento centrale deve essere posizionato in corrispondenza dell'unione degli elementi.
- Nella configurazione a muro (VERNER) il basamento deve essere regolato per poter avere la composizione a ridosso della parete.
- I top nelle composizioni della stessa finitura, impiallacciato rovere e lacca opaca/lucida, saranno interi per una lunghezza max di mt. 3.
- Il modulo 60 con vano aperto e il modulo ANGOLO, nelle versioni VERNER e VERNER DOUBLE FACE hanno sempre il top dedicato.

- For the composition of the modules, make sure to insert the finishing shoulder on each side element (right and left).
- The open unit 60 modular does not need a finishing shoulder for the side element version.
- The open unit 60 modular cannot be configured next to another equal element due to technical issues.
- The open unit 60 modular and ANGLE one, in VERNER and VERNER DOUBLE FACE versions always have a finishing backrest.
- The open unit 60 modular, the open unit 60 modular with door and ANGLE one cannot be used as single elements.
- The side base must be configured only on the side elements. Instead the central base must be positioned at the union of the elements.
- In the wall configuration (VERNER) the base must be adjusted in order to have the composition close to the wall.
- The tops in oak veneer and matt / glossy lacquer, with compositions of the same finish, will be whole for a maximum length of mt. 3.
- The open unit 60 modular and ANGLE one, in VERNER and VERNER DOUBLE FACE versions always have the dedicated top.

- Achten Sie bei der Zusammenstellung der Module darauf, die Abschlusschulter an jedem Seitenelement (rechts und links) einzufügen.
- Das Modul 60 offen benötigt in der Seitenelementversion keine Abschlusschulter.
- Das Modul 60 offen kann aus technischen Gründen nicht neben einem anderen gleichen Element konfiguriert werden.
- Das Modul 60 offen und das ECK-MODUL, in den Versionen VERNER und VERNER DOUBLE FACE, haben immer eine verarbeitete Rückenlehne.
- Das Modul 60 offen, das Modul 60 mit Tür und ECK-MODUL können nicht als Einzelelemente verwendet werden.
- Das seitliche Gestell kann nur an den Seitenelementen konfiguriert werden. Das Mittelgestell muss dagegen an der Vereinigung der Elemente positioniert werden.
- In der Wandkonfiguration (VERNER) muss das Gestell so eingestellt werden, dass die Zusammensetzung nahe an der Wand liegt.
- Bei Kompositionen in derselben Ausführung (nur aus Eichenfurnier und Lack matt/Hochglanz), werden die Platten durchgehend sein, mit einer maximalen Länge von 3 mt.
- Das Modul 60 offen und das ECK-MODUL, in den Versionen VERNER und VERNER DOUBLE FACE haben immer ihre eigene Oberfläche.

- En assemblant les éléments modulaires, merci de bien insérer le panneau latéral fini à chaque élément latéral (droit et gauche).
- L'élément 60 ouvert, lorsqu'il est utilisé comme élément latéral, n'a pas besoin du panneau latéral fini.
- Pour des raisons techniques, on ne peut pas utiliser des éléments 60 ouverts l'un à côté de l'autre.
- L'élément 60 ouvert et l'élément ANGLE, pour les versions VERNER et VERNER DOUBLE FACE, ont toujours le panneau du dossier fini.
- L'élément 60 ouvert, l'élément 60 avec porte et l'élément ANGLE ne peuvent pas être utilisés tous seuls.
- La base latérale doit être utilisée seulement sur les éléments latéraux. En revanche, la base centrale doit être placée en correspondance de la jonction des éléments.
- Pour la version du meuble au mur (VERNER), la base doit être réglée, afin d'avoir le meuble appuyé au mur.
- Les plateaux des compositions jusqu'à 3 mètres de longueur maximum et dans la même finition, soit en chêne teinté soit en laque mate/brillante, seront entiers.
- En revanche, l'élément 60 ouvert et l'élément ANGLE, pour les versions VERNER et VERNER DOUBLE FACE seront toujours réalisés avec plateau séparé.

- Durante la composición de los módulos, asegurarse de insertar correctamente el panel lateral acabado a cada elemento lateral (derecha e izquierda).
- El módulo 60 abierto, cuando utilizado como módulo lateral, no necesita del panel lateral acabado.
- Por razones técnicas, no es posible utilizar los módulos 60 juntos.
- El módulo 60 abierto y el elemento ÁNGULO, para la versión VERNER y VERNER DOUBLE FACE, tienen siempre el panel del respaldo acabado.
- No es posible utilizar el módulo 60 abierto, el módulo 60 con puerta y el elemento ÁNGULO sueltos.
- Es posible utilizar la base lateral solamente con los elementos laterales. En cambio, hay que poner la base central bajo del punto de unión de los módulos.
- En la versión del mueble a pared (VERNER), hay que ajustar la base, para que el mueble resulte contra el muro.
- Los paneles de las composiciones hasta 3 metros de largo y con el mismo acabado, tanto en roble enchapado como en lacado brillo/mate, van a ser una pieza única.
- El módulo 60 abierto y el elemento ÁNGULO, para la versión VERNER y VERNER DOUBLE FACE, van a ser realizados siempre con panel separado.

# VERNER DOUBLE FACE 2019

esempio di composizione bifacciale con vano giorno posto centralmente  
*example of a two-sided composition with a day room located centrally*

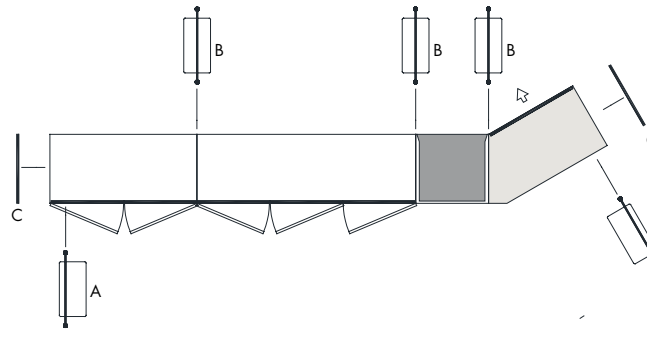
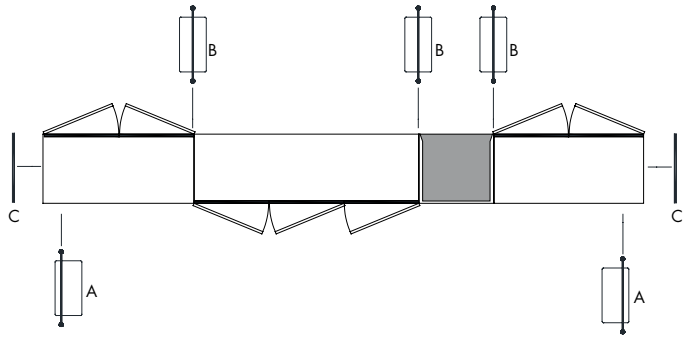

A - basamento laterale  
 conteggiare sempre N° 2  
 basamenti laterali

A - side stand  
 always count N° 2  
 side bases



B - basamento centrale  
 conteggiare N° basamenti  
 centrali tanti quante  
 sono le "giunture" della  
 composizione

B - central basement  
 counting as many central  
 bases as there are "joints"  
 of the composition

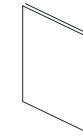

C - spalla  
 conteggiare N° 2  
 spalle di finitura

C - shoulder  
 count N° 2  
 finishing shoulders

esempio di composizione bifacciale con n° 1 vano giorno posto lateralmente  
*example of a double-sided composition with n° 1 day room sideways*

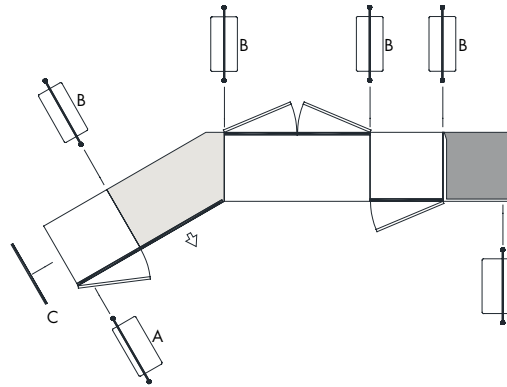
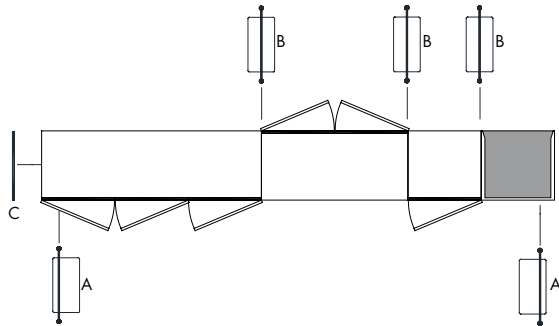

A - basamento laterale  
 conteggiare sempre N° 2  
 basamenti laterali

A - side stand  
 always count N° 2  
 side bases



B - basamento centrale  
 conteggiare N° basamenti  
 centrali tanti quante  
 sono le "giunture" della  
 composizione

B - central basement  
 counting as many central  
 bases as there are "joints"  
 of the composition

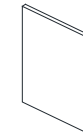

C - spalla  
 conteggiare N° 1  
 spalle di finitura

C - shoulder  
 count N° 1  
 finishing shoulders

esempio di composizione bifacciale con n° 2 vani giorno posti lateralmente  
*example of double-sided composition with n° 2 day spaces placed laterally*

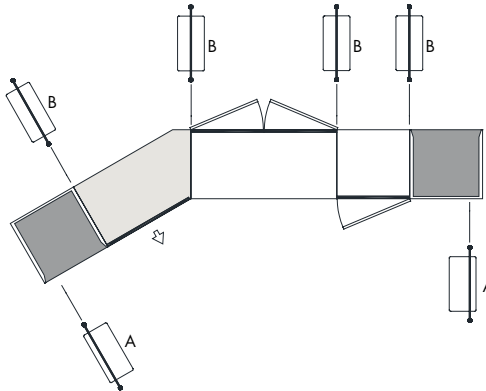
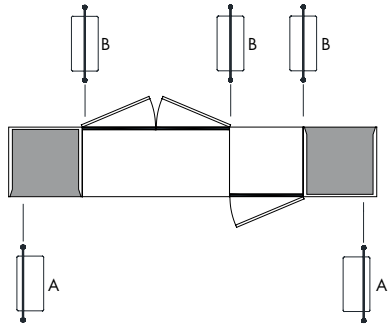

A - basamento laterale  
 conteggiare sempre N° 2  
 basamenti laterali

A - side stand  
 always count N° 2  
 side bases



B - basamento centrale  
 conteggiare N° basamenti  
 centrali tanti quante  
 sono le "giunture" della  
 composizione

B - central basement  
 counting as many central  
 bases as there are "joints"  
 of the composition

NESSUNA  
 spalla di finitura

NONE  
 shoulder finishing

## VERNER DOUBLE FACE 2019

· contenitori modulari componibili per centro stanza

bifacciali:  
 modulo 60 con vano aperto  
 modulo 120 con un'anta  
 modulo 180 con due ante  
 modulo 180 con tre ante  
 modulo CORNER con cassettone

· finiture esterne:  
 impiallacciatura rovere tinto (interno rovere tinto)  
 lacca opaca o lucida (interno lacca opaca)  
 rivestimento ottone bronzato o acciaio platinato  
 con lacca opaca o lucida (interno lacca opaca)  
 · basamento regolabile in metallo  
 varnished opaco black  
 · accessori interni optional  
 · **ripiano**  
 · **cassettera**

finiture: vedi campionario

attenzione: per la realizzazione di composizioni  
 allegare all'ordine un disegno  
 imballo obbligatorio in gabbia

· modular containers for double-sided room center:

unit 60 with open compartment  
 unit 60 with a door  
 unit 120 with two doors  
 unit 180 with three doors  
 CORNER unit with drawer

· external finishes:  
 stained oak veneer (internal frame in stained oak)  
 matt or glossy lacquer (internal frame in matt lacquer)  
 coated in bronzed brass or platinum steel with  
 matt or glossy lacquer (internal frame in matt lacquer)  
 · adjustable metal base  
 black matt varnished  
 optional inner accessories

· **shelf**  
 · **chest of drawers**

finishes: see sample box

attention: for compositions, always attach sketches  
 of configurations to orders  
 compulsory packing in wooden cage

· Modulare und beidseitige Elemente für Raummitte:

Modul 60 offen  
 Modul 60 mit einer Tür  
 Modul 120 mit zwei Türen  
 Modul 180 mit drei Türen  
 Modul CORNER mit Schublade

· Außenausführungen:  
 Eiche furniert gebeizt (innen Eiche gebeizt)  
 matt oder Hochglanz lackiert (innen Lack matt)  
 messing bronziert oder platinum steel mit matt oder  
 Hochglanz lackiert (innen Lack matt)  
 · verstellbaren Metall Gestell  
 black varnished  
 · Zusätzliche Innenausstattung

· **Fachboden**  
 · **Schubladenkasten**

Ausführungen: siehe Musterbox

Vorsicht: bei Kompositionen fügen Sie der  
 Bestellung eine Zeichnung bei  
 Obligatorische Verpackung in Holzkiste

· meubles de rangement modulaires à utiliser en

centre de pièce, donc finis sur toutes les côtés:  
 module 60 avec niche ouverte  
 module 60 avec une porte  
 module 120 avec deux portes  
 module 180 avec trois portes  
 module CORNER avec grand tiroir

· finitions pour l'extérieur:  
 placage de chêne teinté (intérieur chêne teinté)  
 laque mate ou brillante (intérieur en laque mate)  
 couverture en laiton bronzé ou platinum steel avec  
 laque mate ou brillante (intérieur en laque mate)  
 · base en métal réglable  
 verni couleur black  
 · optionnel accessoires pour l'intérieur

· **étagère**  
 ·  **tiroirs**

finitions: voir nos échantillons

attention: pour des compositions modulaires, merci  
 de joindre à la commande le schéma correspondant  
 emballage en cage en bois obligatoire

· cajas de almacenamiento modulares que se

utilizan en el medio de la habitación, por eso  
 acabados en todos lados:  
 módulo 60 con vano abierto  
 módulo 60 con una puerta  
 módulo 120 con dos puertas  
 módulo 180 con tres puertas  
 módulo CORNER con cajonera

· acabados exteriores:  
 enchapado exterior en roble teñido  
 lacado mate o brillo (interior lacado mate)  
 revestimiento latón bronceado o platinum steel  
 con lacado mate o brillo (interior lacado mate)  
 · base en metal regulable  
 barnizada black  
 · opcionales accesorios interiores

· **estante**  
 · **cajonera**

acabados: vease el muestrario

atención: para composiciones adjuntar el dibujo a la orden  
 embalaje en jaula de madera obligatorio

## contenitore aperto - open storage unit 60

elemento bifacciale

double face element

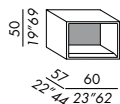

basamento laterale

side base

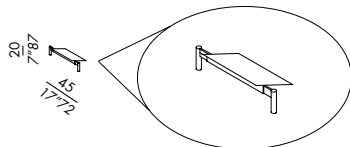

basamento centrale

central base

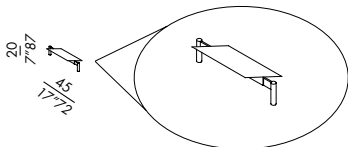

**contenitore - storage unit 60**

elemento bifacciale  
double face element

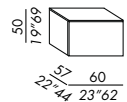

anta sx - left door



versione ottone bronzato o acciaio platinato  
bronzed brass or platinum plated steel

spalla  
side panel



basamento laterale  
side base

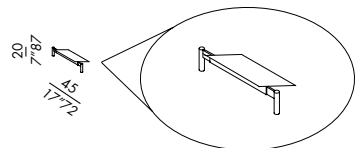

basamento centrale  
central base

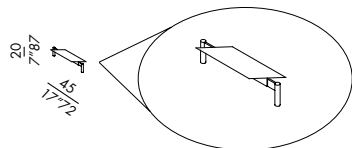

options:

ripiano - shelf  
60

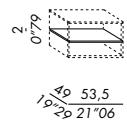

cassettiera - chest of drawers  
60

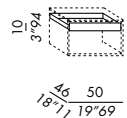

**contenitore - storage unit 120**

elemento bifacciale  
double face element

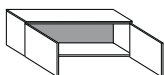
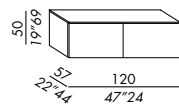

spalla  
side panel

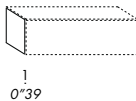

basamento laterale  
side base

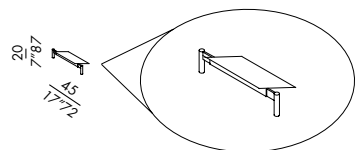

basamento centrale  
central base

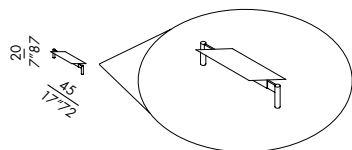

options:

ripiano - shelf  
120

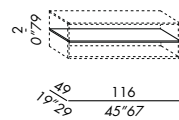

**contenitore - storage unit 180**

elemento bifacciale  
double face element

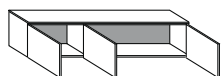
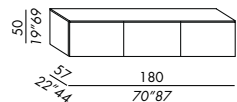

vano 60 sx - left compartment 60



versione ottone bronzato o acciaio platinato  
bronzed brass or platinum plated steel

spalla  
side panel

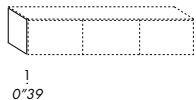

basamento laterale  
side base

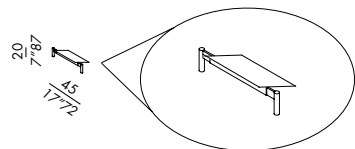

basamento centrale  
central base

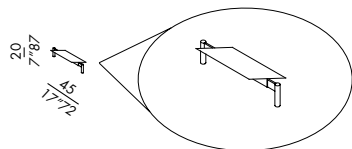

options:

ripiano - shelf  
60 / 120

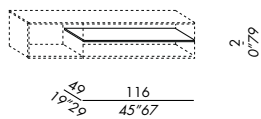
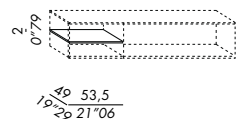

cassettiera - chest of drawers  
60

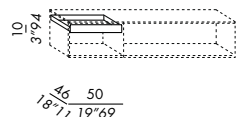

**contenitore ANGOLARE CHIUSO - storage unit CLOSED CORNER**

elemento bifacciale  
double face element

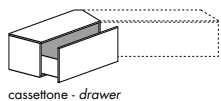
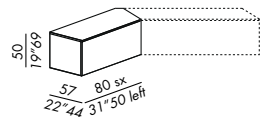

spalla  
side panel

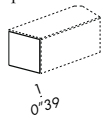

basamento laterale  
side base

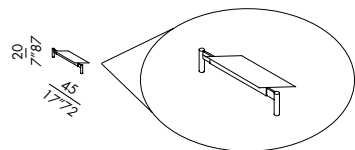

basamento centrale  
central base

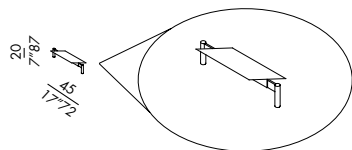

**contenitore ANGOLARE APERTO - storage unit OPEN CORNER**

elemento bifacciale  
double face element

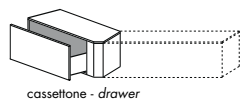
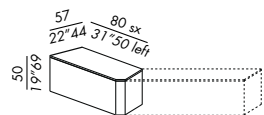

spalla  
side panel

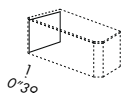

basamento laterale  
side base

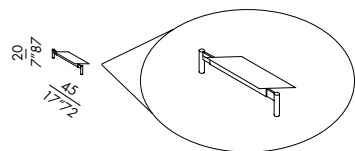

basamento centrale  
central base

