

# BUBBLE GOLD

## TECHNICAL DATA

[ITA]

**STRUTTURA**

Realizzata in multistrato di betulla di spessore 18 mm con masselli in legno di abete massiccio di vari spessori. Tutto in classe E1, pertanto abbassa emissione di formaldeide.

**MOLLEGGIO**

È realizzato in nastri da 80 mm tesi meccanicamente, composti da fili di nylon avvolti a spirale.

**IMBOTTITURA**

Le sedute sono in poliuretano espanso flessibile ed indeformabile a quote differenziate. Composto da due strati di densità diversa, sopra D23 HS e sotto D30 G in falda termolegata 300gr/mq.

Tutto completamente rivestito in resinato 200 gr accoppiato a maglia 100% poliestere.

Cuscini in fiocco vergine siliconato di poliestere contenuti in tessuto non tessuto.

**PIEDI**

Piede in ABS nero H40 non visibile + ruote H40 antidrucciolo non visibili.

[ENG]

**FRAME**

Frame made of 18 mm thick multi-layered birch and solid fir wood in various thicknesses. All in Class E1, therefore with low formaldehyde emissions.

**SPRINGING**

Made of 80 mm wide mechanically tensioned webbing composed of nylon strands wound into a spiral.

**PADDING**

Seats made of flexible, non-deformable polyurethane foam in different densities. Composed of two layers of different densities, D23 HS on top and D30 G underneath in 300g/sq. m thermo-bonded felt

Completely upholstered in 200 g resin bonded to 100% polyester jersey.

Cushions made of virgin siliconised polyester flock contained inside non-woven fabric.

**FEET**

Black ABS plastic feet H40, not visible + H40 non-slip wheels, not visible.

Sedute a quote differenziate per offrire maggior comfort.

Seats of different densities for greater comfort.

Assises à quota différencié afin d'offrir un majeur confort.

Asientos con densidad diferenciada para ofrecer mayor comodidad.

[FRA]

**STRUCTURE**

Réalisée en multicouches de bouleau d'épaisseurs 18 mm et en bois massif de pin de différentes épaisseurs. Tout en Classe E1, donc à basse émission de formaldéhydes.

**SUSPENSION**

Réalisée avec des bandes élastiques de 80 mm tendues mécaniquement, composées par des fils de gomme recouverts par du fil de nylon enroulé à spirale

**REMBOURRAGE**

Les assises sont en expansé flexible et indéformable de polyuréthane à quota différencié. Composé par deux strates de densité différente, dessus en D23 HS et dessous en D30 G, en couche thermo-liée 300 gr/mc.

Tout est entièrement revêtu en résiné 200 gr couplé à une maille 100% polyester. Coussins en mousse vierge siliconée de polyester en tissu non tissu.

**PIEDS**

Pieds en ABS noir H. 40 mm, non visibles + roues H.40 mm antidérapantes, non visibles.

[ESP]

**ESTRUCTURA**

Realizada con madera contrachapada de abedul de 18 mm de grosor, con armazón de madera maciza de abeto de distintos grosores. Todo en clase E1, es decir de baja emisión de formaldehído.

**SISTEMA DE SUSPENSIÓN**

Realizado con cinchas de 80 mm, tensadas mecánicamente, compuestas por hilos de nylon envueltos en forma de espiral.

**RELLENO**

Los asientos son en espuma de poliuretano flexible e indeformable de densidad diferenciada. Compuesto por dos capas de distinta densidad, D23HS en la parte superior y D30G en la parte inferior con capa ligada térmicamente de 300 g/m2.

Todo completamente revestido con fibra resinada de poliéster de 200 gramos, acoplada con tejido de punto 100% poliéster. Cojines en floc de poliéster siliconada virgen contenida en tejido sin tejer.

**PATAS**

Patatas de ABS negro de 40 mm de altura, no visibles con ruedas también de 40 mm de altura, antideslizantes y no visibles.



# FILATI

## SPUNS – FILÉS – HILOS

## TECHNICAL DATA



Disponibili cuciture di finitura in tinta e/o in contrasto. — Available with top stitching in the same and/or contrasting colour.  
Disponibilité des coutures de finition en teinte et/ou en contraste. — Disponibles costuras de acabado del mismo color y/o en contraste.

2000		113		600		326		864	
419		118		1411		379		1097	
42		123		869		1185		1091	
415		504		575		565		816	
4000		1314		578		262		821	

# SISTEMA REVERSIBILE SX

TECHNICAL DATA

REVERSIBLE SYSTEM LH | SYSTÈME REVERSIBLE GCH | SISTEMA REVERSIBLE SX

VISTA SOPRA  
VIEW FROM ABOVE - VUE DE DESSUS - VISTA DESDE ARRIBA

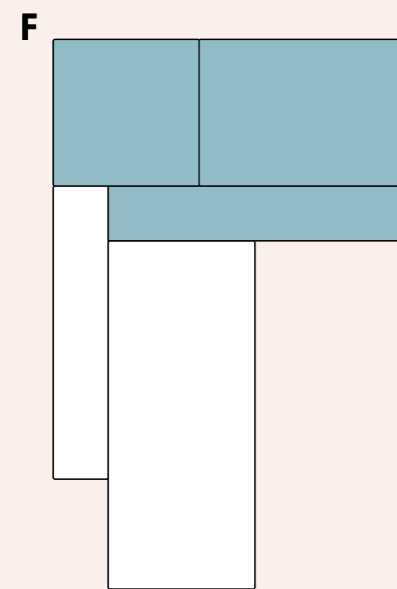
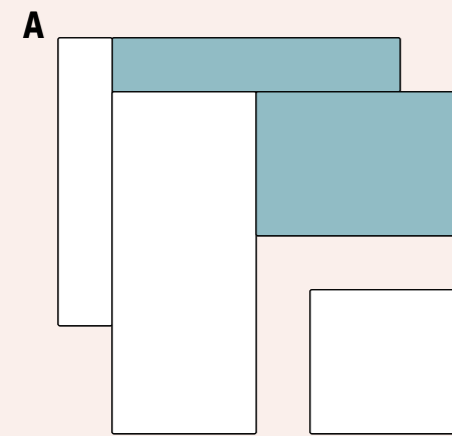

VISTA SOTTO  
VIEW FROM BELOW - VUE DE DESSOUS - VISTA DESDE ABAJO

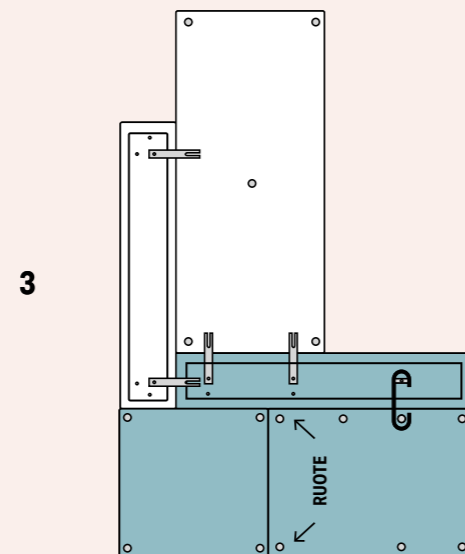
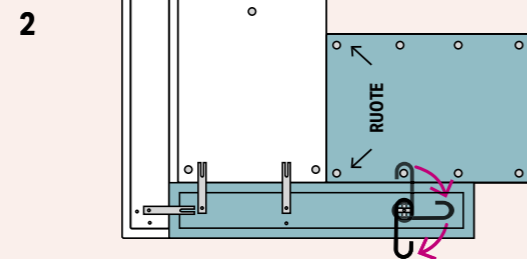
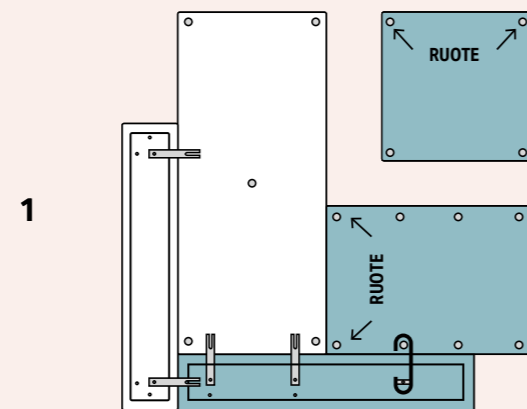

# SISTEMA REVERSIBILE DX

TECHNICAL DATA

REVERSIBLE SYSTEM RH | SYSTÈME REVERSIBLE DTE | SISTEMA REVERSIBLE DX

VISTA SOPRA  
VIEW FROM ABOVE - VUE DE DESSUS - VISTA DESDE ARRIBA

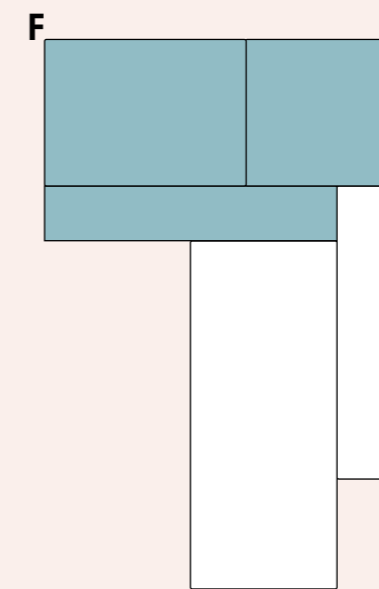
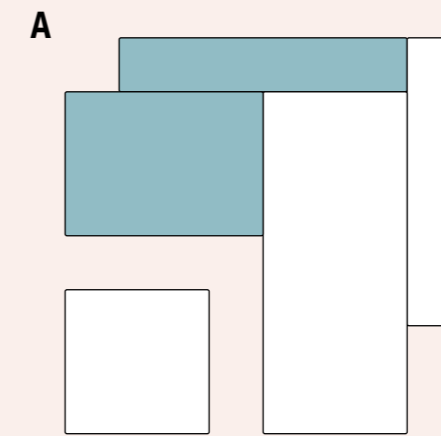

VISTA SOTTO  
VIEW FROM BELOW - VUE DE DESSOUS - VISTA DESDE ABAJO

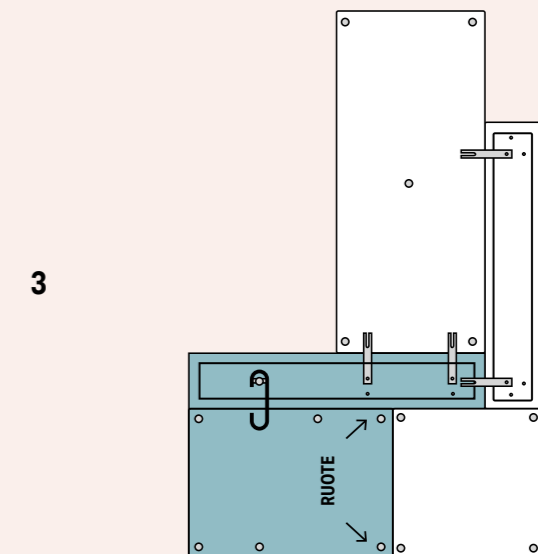
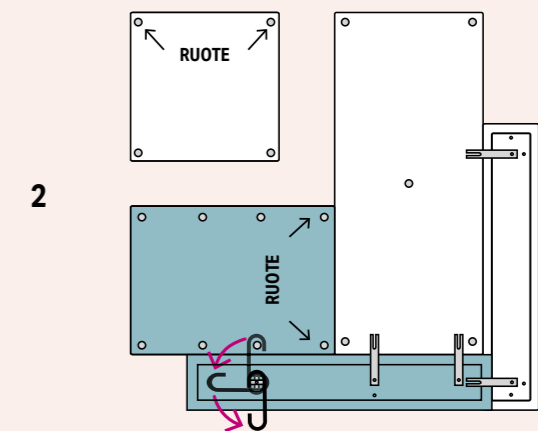
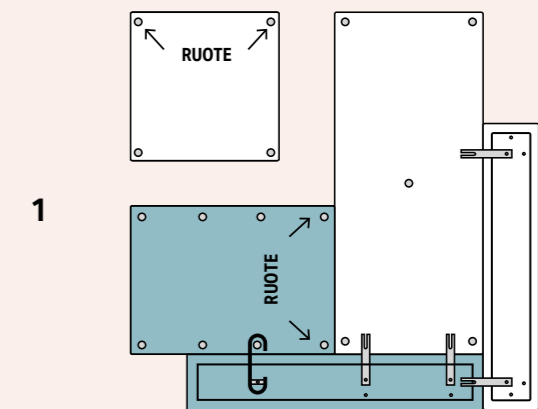

# BUBBLE GOLD STANDARD SX TECHNICAL DATA

COMPOSIZIONI | ARRANGEMENTS | COMPOSITIONS | COMPOSICIONES

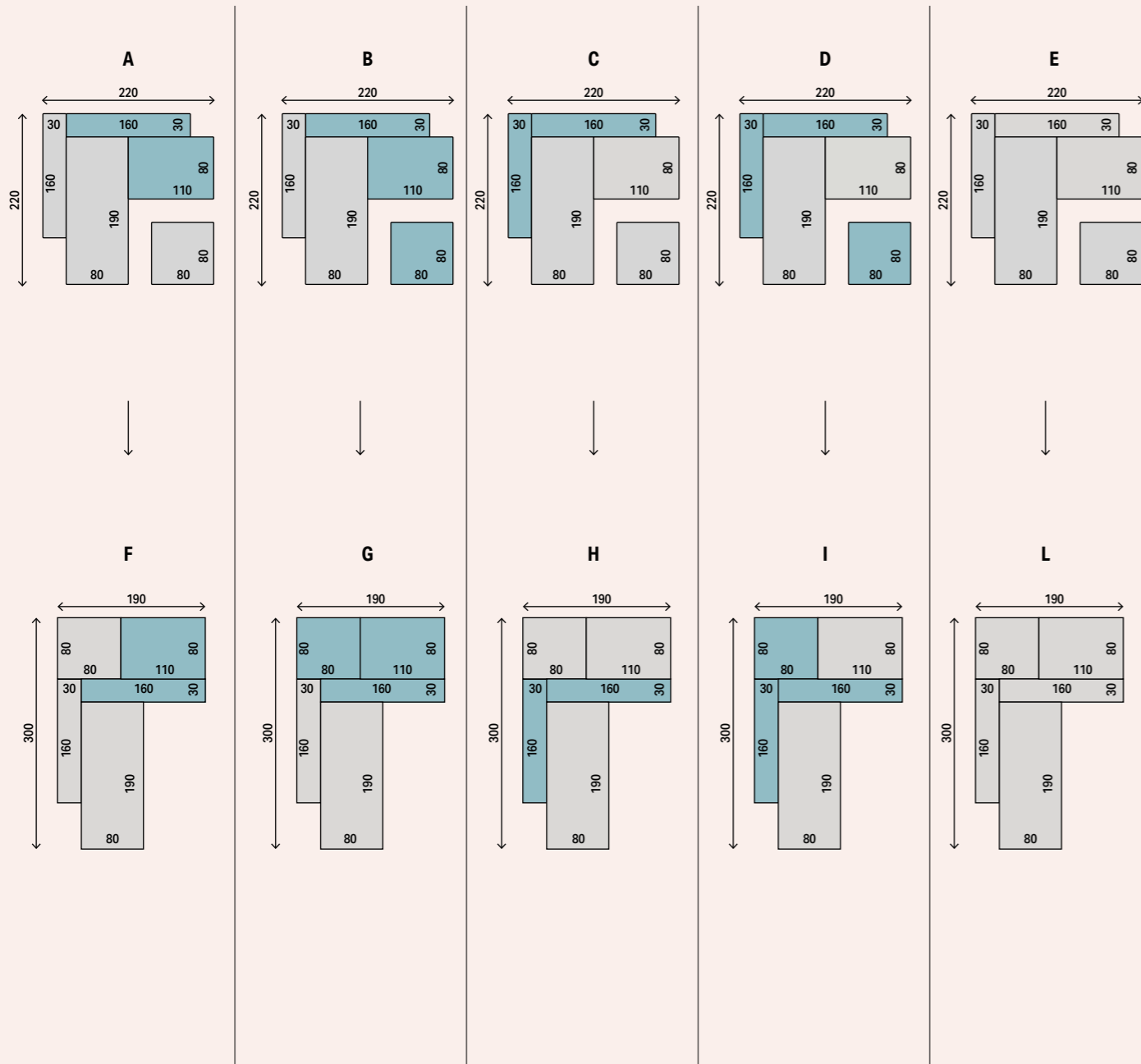

# BUBBLE GOLD MAXI SX TECHNICAL DATA

COMPOSIZIONI | ARRANGEMENTS | COMPOSITIONS | COMPOSICIONES

