

F
L
O
A
T

josastini

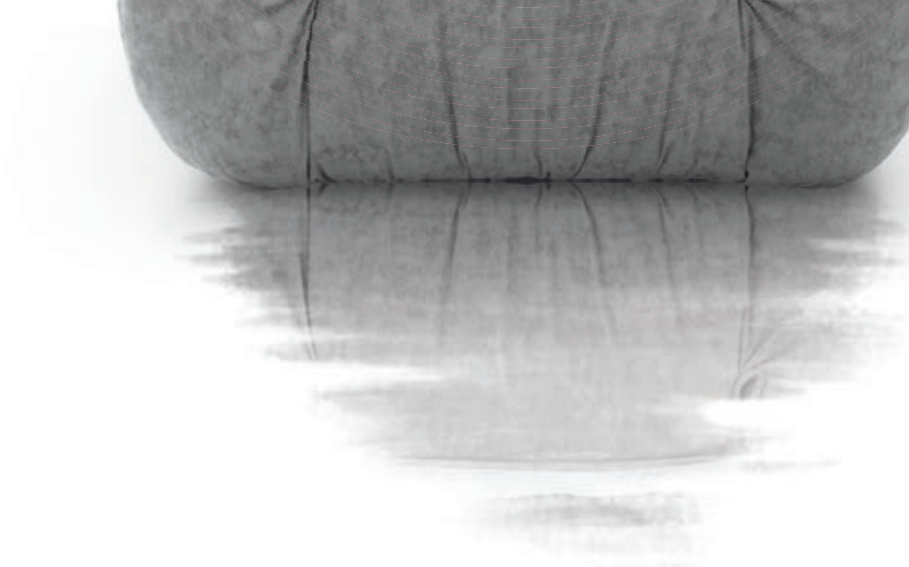



Considerato uno degli architetti e designer italiani di maggior spicco nel panorama internazionale del progetto, Massimo Iosa Ghini ha partecipato negli anni Ottanta alle avanguardie progettuali fondando il movimento culturale Bolidismo e facendo parte del gruppo Memphis di Ettore Sottsass. Nel 1990 apre la Iosa Ghini Associati, che oggi opera internazionalmente, sviluppando progetti per grandi gruppi e developer internazionali e occupandosi di design di prodotto, interiors e architettura. Massimo Iosa Ghini, Ambasciatore del Design Italiano e del Red Dot Network, Socio Effettivo del Comitato Leonardo e della Accademia Clementina, ha ricevuto il Premio Marconi per la Creatività nel 2015.

Considéré un des architectes et designer italiens plus éminents au niveau international du projet, Massimo Iosa Ghini a participé dans les années quatre-vingt à des projets d'avant-garde en fondant le mouvement culturel Bolidismo et en faisant partie du groupe Memphis de Ettore Sottsass. En 1990 il crée Iosa Ghini Associés, qui à ce jour œuvre au niveau international, en développant des projets pour de grands groupes et pour des concepteurs internationaux, en s'occupant de design de produits, d'intérieurs et d'architecture. Massimo Iosa Ghini, Ambassadeur du Design Italien et du Network Red Hot, Associé Effectif du Comité Leonardo et de l'Académie Clementina, a reçu en 2015 le Prix Marconi de la Créativité.

Considered one of the most prominent Italian architects and designers on the international design scene, Massimo Iosa Ghini participated in the Eighties in the design avantgarde, founding the cultural movement of Bolidismo and participating in the Memphis group of Ettore Sottsass. In 1990 he opened the studio Iosa Ghini Associates, which now operates on international level, developing projects for large groups and international developers and designing interiors, products and architectures. Massimo Iosa Ghini, appointed Ambassador of Italian Design and Red Dot Network, Active Member of Leonardo Committee and Effective Member of the Accademia Clementina, received the Marconi Award for Creativity in 2015.

Massimo Iosa Ghini gilt als einer der bedeutendsten italienischen Architekten und Designer in der internationalen Designszene und war in der 80er Jahren, nahm er an der Design-Avantgarde Teil, indem er die kulturelle Bewegung Bolidismo gründete und zur Memphis-Gruppe von Ettore Sottsass gehörte. Im Jahr 1990 eröffnete er das Büro Iosa Ghini Associati, das heute international tätig ist und Projekte für große internationale Konzerne und Bauträger entwickelt und sich mit Produktdesign, Inneneinrichtung und Architektur beschäftigt. Massimo Iosa Ghini – Botschafter des italienischen Designs und des Red Dot Networks, Vollmitglied des Leonardo-Komitees und der Accademia Clementina – erhält 2015 den Marconi-Preis für Kreativität.

MASSIMO IOSA GHINI

Float è il morbido realizzarsi di un'ispirazione. Assenza di forma che si fa comfort estremo, alla vista prima ancora che nell'uso. Abbondanza di materiale che accoglie in un dolce invito a sedersi.

Float est la réalisation douce d'une inspiration. Absence de forme qui devient confort extrême, à regarder avant même de l'utiliser. Abondance de matériel qui vous accueille en une invitation douce à s'asseoir.

Float is the soft fulfilment of an inspiration. Absence of shape becomes extreme comfort, to the eye even before use. An abundance of material that welcomes you with a gentle invitation to take a seat.

Float ist die weiche Verwirklichung einer Inspiration. Eine nicht vorhandene Form, die zu extremem Komfort wird, beim Anblick noch vor dem Gebrauch. Üppig verwendetes Material, das eine sanfte Einladung zum Sitzen darstellt.





Il disegno del divano, qui nella versione lineare, nasce da un segno architettonico molto semplice: la curva, forma naturale, capace di aprire un dialogo tra leggerezza, morbidezza e volumi.

Le dessin du canapé, qui dans la version linéaire, naît d'un signe architectonique très simple : la courbe, forme naturelle, capable d'ouvrir un dialogue entre légèreté, souplesse et volumes.

The design of the sofa, here in the linear version, stems from a very simple architectural form: the curve, a natural shape able to open a dialogue between lightness, softness and volumes.

Das Design des Sofas, hier in der linearen Version, geht von einem sehr einfachen baulichen Merkmal aus: der Kurve, einer natürlichen Form, die einen Dialog zwischen Leichtigkeit, Weichheit und Volumen eröffnet.









La collezione Float svela sé stessa nella fluidità, così contemporanea, delle sue linee. E in quel raffinato mettersi in mostra delle pieghe, gioco stilistico che richiama in un andirivieni il movimento delle onde.

La collection Float se dévoile dans la fluidité, ainsi que contemporanéité, de ses lignes. Et dans la capacité raffinée de mettre en avant ses plis, jeu de style qui rappelle un va-et-vient du mouvement des vagues.

The Float collection manifests itself in the fluidity of its contemporary lines. And in the refined showcasing of the pleats, a play on style that evokes in its movement back and forth, the motion of the waves.

Die Kollektion Float besticht durch eine fließende, zeitgemäße Linienführung. Und durch eine raffinierte Darstellung der Falten, ein stilistisches Spiel, das an die Bewegung der Wellen in einem Kommen und Gehen erinnert.







Float è un sistema ad alta componibilità che lascia ampio spazio alla progettazione. Per una seduta ancora più confortevole, ad esempio, è possibile combinare la chaise longue con gli altri moduli, oppure optare per una dormeuse in modalità stand alone o in abbinamento con un'altra dormeuse.

Float est un système à haute modularité qui laisse ample place à la conception. Pour une assise encore plus confortable, par exemple, il est possible de combiner la chaise longue avec d'autres modules, ou opter pour une dormeuse en modalité stand alone ou en combinaison avec une autre dormeuse.

Float is a highly modular system that leaves plenty of scope for design. For even more comfortable seating, for example, the chaise longue can be combined with the other sections or opt for a stand-alone daybed or combine one daybed with another.

Float ist ein hochgradig modulares System, das viel für noch mehr Sitzkomfort kann man, zum Beispiel, die Chaiselongue mit den anderen Modulen kombinieren oder für eine Dormeuse als Stand Alone versione oder in Kombination mit einer anderen Dormeuse entscheiden.









Ci sono tanti modi per vivere Float, perché diversi sono i momenti di relax. Sedersi in modo convenzionale è solo una delle possibilità: grazie ai suoi morbidi braccioli, o alla maxi profondità delle due dormeuse combinate, Float è un invito a sdraiarsi, a risposare, a svagarsi, a sognare.

Il existe beaucoup de façon de vivre Float, car différents sont les moments de relax. S'asseoir de façon conventionnelle est uniquement une des possibilités : grâce à ses accoudoirs souples, ou la maxi profondeur des deux dormeuses combinées, Float invite à s'allonger, à se reposer, à se distraire, à rêver.

There are many ways to enjoy Float, because there are many different opportunities to relax. Sitting in the conventional way is just one option: thanks to its soft armrests, or the maxi depth of the two combined daybeds, Float invites you to lie down, rest, unwind and dream.

Es gibt viele Möglichkeiten, Float zu erleben, denn die Momente der Entspannung sind unterschiedlich. Ein normales Sitzen ist nur eine der Möglichkeiten: Dank der weichen Armlehnen oder der maximalen Tiefe zweier kombinierter Dormeuse-Modellen ist Float eine Einladung zum Liegen, zum Ausruhen, zum Entspannen, zum Träumen.



Tutti gli elementi, da quelli centrali a quelli angolari, sono rifiniti su ogni lato e non presentano agganci visibili. In questo modo possono essere utilizzati in composizione o a sé stanti, per la massima libertà compositiva.

Tous les éléments, de ceux centraux à ceux d'angle, sont finis sur chaque côté et ne présentent aucune fixation visible. De cette façon ils peuvent être utilisés en composition ou seul, suivant la plus grande liberté de composition.

All the elements, from central to corner sections, are finished on every side and have no visible couplings. This means that they can be used in arrangements or on their own, for maximum creative freedom.

Alle Elemente, von den zentralen bis hin zu den Eckelementen, sind allseitig verarbeitet und haben keine sichtbaren Einrastelemente. Auf diese Weise können sie kombiniert oder freistehend verwendet werden und bieten so freie Gestaltungsmöglichkeiten.



FLOAT

TECHNICAL SECTION

STRUTTURA

Struttura realizzata con masselli portanti in legno di abete massiccio di vari spessori, parti di tamponamento in fibra grezza e/o compensato. Fianchi in agglomerato di legno e/o multistrato di legno da 18 mm. Fibra grezza e agglomerato di legno in classe E1, pertanto a bassa emissione di formaldeide. Il telaio è rivestito con resinato da 200 gr. termoaccoppiato a vellutino 100% poliestere.

IMBOTTITURA

Seduta in poliuretano espanso indeformabile D35 SR. Schienale e braccioli in espanso indeformabile D18 SS.

MOLLEGGIO

Realizzato con nastri elastici da 80 mm tesi meccanicamente, composti da fili di nylon avvolti a spirale.

PIEDI

Piedi in ABS nero da H 40 mm, non visibili.

FRAME

Made of solid fir wood in various thicknesses. Reinforcement parts in wood fibre and/or plywood. Sides made of 18 mm particleboard and/or multi-layered wood. Wood fibre and particleboard Class E1 therefore low formaldehyde emissions. The frame is upholstered with 100% polyamide velveteen thermo-bonded to 200 g 100% polyester resin wadding.

PADDING

Seat made of non-deformable polyurethane foam D35 SR. Backrest and armrests made of flexible foam D18 SS.

SPRINGING

Made of 80 mm wide mechanically tensioned webbing composed of nylon strands wound into a spiral.

FEET

Black ABS plastic feet H 40 mm, not visible.

STRUCTURE

Réalisée en bois massif de pin portant de différentes épaisseurs. Fileurs de remplissage en fibre brute et/ou contreplaqué. Côtés en aggloméré de bois et/ou multicouches de bois 18 mm. Fibre brute et aggloméré de bois en Classe E1, donc à basse émission de formaldéhydes. Le châssis est revêtu par du velours 100% polyamide couplé à chaud à de l'ouate résinée de 200 gr. 100% polyester.

REMBOURRAGE

Assise en expansé indéformable de polyuréthane D35 SR. Dossier et accoudoirs en expansé flexible et indéformable de polyuréthane D18 SS.

SUSPENSION

Réalisée avec des bandes élastiques de 80 mm tendues mécaniquement, composées par des fils de gomme recouverts par du fil de nylon enroulé à spirale.

PIEDS

Pieds en ABS noir H. 40 mm, non visibles.

KORPUS

Aus massivem Tannenholz in verschiedenen Stärken, Füllungen aus Rohfaser und/oder Sperrholz. Seiten aus 18 mm Spanplatte. Alles entspricht der Klasse E1, also mit geringer Formaldehydabgabe. All dies ist mit Samt aus 100% Polyamid bezogen, der mit Schaumstoff und/oder geharztem Material zu 200 g heiß aufkaschiert wurde, der bzw. Das wiederum auf Samt aus 100% Polyesterfaser heiß aufkaschiert wurde.

POLSTERUNG

Sofasitz aus formstabilem Polyurethanschaum D35 SR. Rückenlehne und armlehnen Polyurethanschaum D18 SS.



FEDERUNG

Besteht aus elastischen, mechanisch gespannten 80mm breiten Gurten, die aus Gummifäden bestehen, die mit spiralförmig gewickelten Nylonfäden ummantelt sind.

FÜSSE

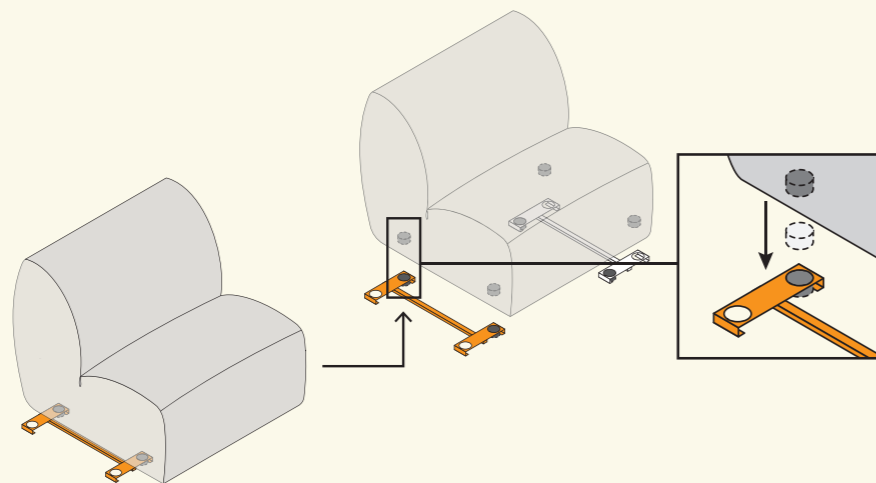
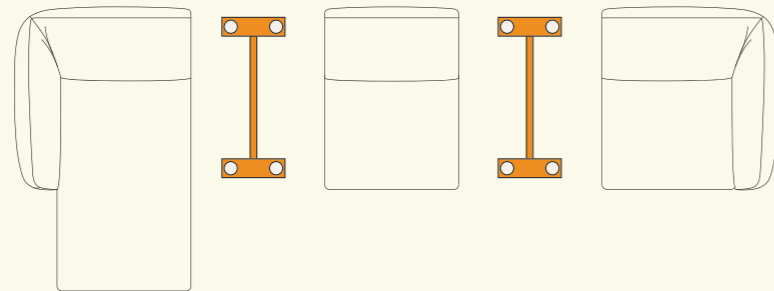

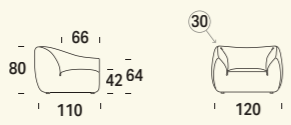
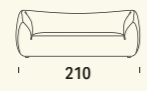
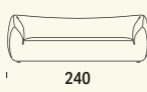
40 mm hohe Füße aus nicht sichtbarem ABS in Schwarz.

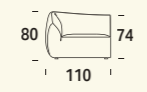
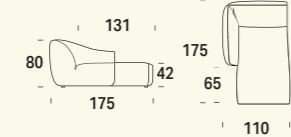
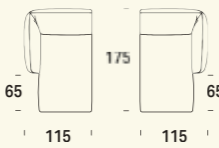

Kg	C S L V D E M P							
	€ T. CLIENTE	SUPER	LUSSO	VIP	DE LUX	ELITE	MAXI	PRESTIGE
45								
Art. / Item Art. / Art.	01							
Poltrona Armchair Fauteuil Sessel								
Mt. tessuto base / Fabric l.m. / Métrage Base / Meter Grundgewebe Volume mc / Volume m³ / Volume m³ / Volumen m³	8.9 1.1							
82								
Art. / Item Art. / Art.	03							
Divano 3 posti Large 3-seater Large sofa Canapé 3 places Large 3-Sitzer-Sofa Large								
Mt. tessuto base / Fabric l.m. / Métrage Base / Meter Grundgewebe Volume mc / Volume m³ / Volume m³ / Volumen m³	13 1.9							
94								
Art. / Item Art. / Art.	07							
Divano 3 posti Maxi 3-seater Maxi sofa Canapé 3 places Maxi 3-Sitzer-Sofa Maxi								
Mt. tessuto base / Fabric l.m. / Métrage Base / Meter Grundgewebe Volume mc / Volume m³ / Volume m³ / Volumen m³	14.7 2.2							
30								
Art. / Item Art. / Art.	90							
Elemento centrale Central element Chauffeuse Zentrales Element								
Mt. tessuto base / Fabric l.m. / Métrage Base / Meter Grundgewebe Volume mc / Volume m³ / Volume m³ / Volumen m³	4.8 0.7							
40								
Art. SX / Item LH Art. GA / Art. LI	SS	Art. DX / Item RH Art. DR / Art. RE	SD					
Laterale 1 posto 1-seater side element Canapé bâtarde 1 place Seitlich 1 Sitz								
Mt. tessuto base / Fabric l.m. / Métrage Base / Meter Grundgewebe Volume mc / Volume m³ / Volume m³ / Volumen m³	7.3 1							
58								
Art. SX / Item LH Art. GA / Art. LI	CS	Art. DX / Item RH Art. DR / Art. RE	CD					
Chaise longue Chaise longue Chaise longue Chaiselongue								
Mt. tessuto base / Fabric l.m. / Métrage Base / Meter Grundgewebe Volume mc / Volume m³ / Volume m³ / Volumen m³	7.5 1.6							
58								
Art. SX / Item LH Art. GA / Art. LI	DO	Art. DX / Item RH Art. DR / Art. RE	OD					
Dormeuse Daybed Meridienne Recamiere								
Mt. tessuto base / Fabric l.m. / Métrage Base / Meter Grundgewebe Volume mc / Volume m³ / Volume m³ / Volumen m³	7.8 1.6							

LE FODERE DI RICAMBIO COSTANO IL 52% DEL CORRISPONDENTE ARTICOLO. / SPARE COVERS COST 52% OF THE RELATIVE ITEM. / LES HOUSSES DE RECHANGE COÛTENT 52% DU PRIX DE L'ARTICLE CORRESPONDANT. / ERSATZFUTTER KOSTEN 52% DES ENTSPRECHENDEN ARTIKELS.

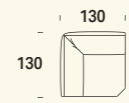
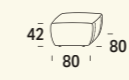
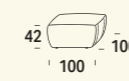
I disegni del listino relativi ad elementi con verso si riferiscono alla versione sinistra. / The drawings in the price list associated with elements with a back refer to the version on the left. / Les dessins du catalogue de prix concernant les éléments avec un sens se réfèrent à la version gauche. / Die Zeichnungen in der Preisliste mit Elementen mit Vers beziehen sich auf die Version auf der linken Seite.

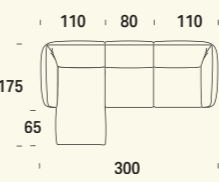
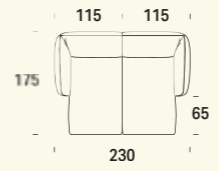
Kg	C S L V D E M P							
	€ T. CLIENTE	SUPER	LUSSO	VIP	DE LUX	ELITE	MAXI	PRESTIGE
57								
Art. / Item Art. / Art.	AQ							
Angolo quadro Square corner Angle carré Quadratische Ecke								
Mt. tessuto base / Fabric l.m. / Métrage Base / Meter Grundgewebe Volume mc / Volume m³ / Volume m³ / Volumen m³	9.1 1.4							
9								
Art. / Item Art. / Art.	10							
Pouf quadro Square pouf Pouf carré Quadratischer Sitzpuff								
Mt. tessuto base / Fabric l.m. / Métrage Base / Meter Grundgewebe Volume mc / Volume m³ / Volume m³ / Volumen m³	3 0.5							
14								
Art. / Item Art. / Art.	11							
Pouf quadro Square pouf Pouf carré Quadratischer Sitzpuff								
Mt. tessuto base / Fabric l.m. / Métrage Base / Meter Grundgewebe Volume mc / Volume m³ / Volume m³ / Volumen m³	4.2 0.6							
12								
Art. / Item Art. / Art.	12							
Pouf rettangolare Rectangular pouf Pouf rectangulaire Rechteckiger Sitzpuff								
Mt. tessuto base / Fabric l.m. / Métrage Base / Meter Grundgewebe Volume mc / Volume m³ / Volume m³ / Volumen m³	3.1 0.6							
128								
Art. / Item Art. / Art.	Composizione 1							
Arrangement 1 Composition 1 Komposition 1								
Mt. tessuto base / Fabric l.m. / Métrage Base / Meter Grundgewebe Volume mc / Volume m³ / Volume m³ / Volumen m³	19.6 3.3							
116								
Art. / Item Art. / Art.	Composizione 2							
Arrangement 2 Composition 2 Komposition 2								
Mt. tessuto base / Fabric l.m. / Métrage Base / Meter Grundgewebe Volume mc / Volume m³ / Volume m³ / Volumen m³	15.6 3.2							

LE FODERE DI RICAMBIO COSTANO IL 52% DEL CORRISPONDENTE ARTICOLO. / SPARE COVERS COST 52% OF THE RELATIVE ITEM. / LES HOUSSES DE RECHANGE COÛTENT 52% DU PRIX DE L'ARTICLE CORRESPONDANT. / ERSATZFUTTER KOSTEN 52% DES ENTSPRECHENDEN ARTIKELS.

I disegni del listino relativi ad elementi con verso si riferiscono alla versione sinistra. / The drawings in the price list associated with elements with a back refer to the version on the left. / Les dessins du catalogue de prix concernant les éléments avec un sens se réfèrent à la version gauche. / Die Zeichnungen in der Preisliste mit Elementen mit Vers beziehen sich auf die Version auf der linken Seite.

felis
SOFT LIVING

FELIS SRL UNIPERSONALE

Via Pietro Zorutti, 22
33074 Fontanafredda (PN) Italy

tel. +39 0434 737052
fax +39 0434 737024

info@felis.it

www.felis.it

Seguici su



art direction
Gianluca Marcon

research and design
Felis Lab

graphic design
Luca Busetto

copywriting
foongo.com

styling
Federica Baro

print
Eurotipo





1990 YEARS 2023

felis
SOFT LIVING