

LASVIT SPACEY MOON MANUAL^{CE}

Spacey Collection
by Lukáš Novák



Contents

Warnings	1
Technical parameters	2
Step-by-step installation	3
Canopy disassembly	4
Fixing point preparation	6
Fixing	7
Electrical wiring	8
Glass canopy mounting	11
Light source replacement	12
Warranties and Warranty Terms and Conditions	15

Markings



Warns you of high risk of damage to the fixture or injury.



Warns you of high risk of electrical injury should a live part be directly or indirectly touched.



Warns you about possible damage to the fixture.



Important information regarding the usage of your fixture.



Gives you general information about the usage of your fixture.

Please read this manual carefully and keep it in case you need assistance while performing maintenance and cleaning procedures.

1/ Warnings

 Risk of electrical injury.

Warns you of high risk of electrical injury should a live part be directly or indirectly touched.

- Before starting any procedures make sure that the power to the lighting fixture is switched OFF and secured against unauthorized, negligent or accidental switching on.

 **Warning**

Warns you of high risk of damage to the fixture or injury.

- Installation and electrical wiring should be carried out by a qualified electrician to prevent any damage to health or property.
- This lighting fixture is to be mounted on fire proof surfaces.
- For indoor use only! Dry location only.
- The manufacturer shall not be held liable for any defects caused by unqualified handling of the lighting fixture.
- Lasvit shall not be held liable for any injuries or damage to the fixture or other property caused during installation or by improper fixing.

 **Important**

Important information regarding the usage of your fixture.

- Installation requires 2 person.
- Fixing material is not part of the lighting fixture kit.
- To retain quality of hand-blown glass, Lasvit recommends to cleaning the glass at least every 3 months, please see Product care manual.
- Proper fixing is the responsibility of the customer.
- The light sources changeable by the customer are provided as a reference gift.



Never dispose of this product in mixed municipal waste, it must be submitted at the designated disposal installation.

2/ Technical parameters

Item ID / CL094CA-1CE

Color variants / lithyalin/opal

Light source / 1 × E27, max 25W

Input voltage / 220 – 240 V, 50/60 Hz

Rated power / max. 25W

Protection rating / IP 20

Safety class / CLASS I

Dimensions / Ø 350 mm x H 480 mm

Weight / approx. 7,5 kg

3/ Step-by-step installation

4. Canopy disassembly
5. Fixing point preparation
6. Fixing
7. Electrical wiring
8. Glass canopy mounting



Consulting a specialist before choosing type of fixing materials and procedures for a given fixture is highly recommended.

Pictures shown are for illustration purposes only.

4/ Canopy disassembly

Step 1

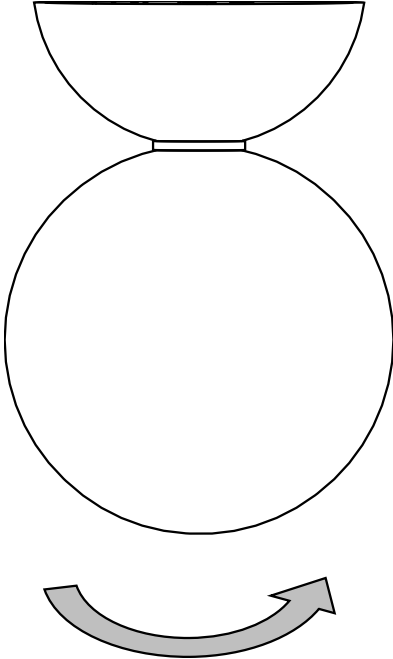

Step 2

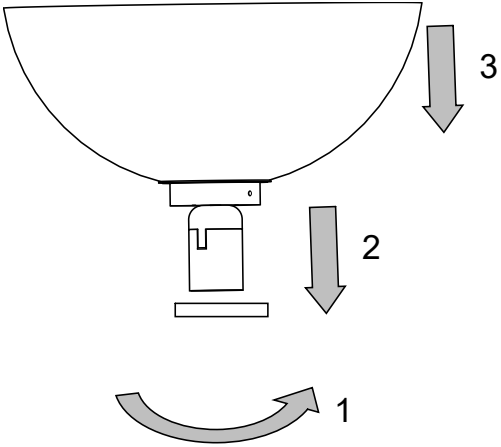

Step 3

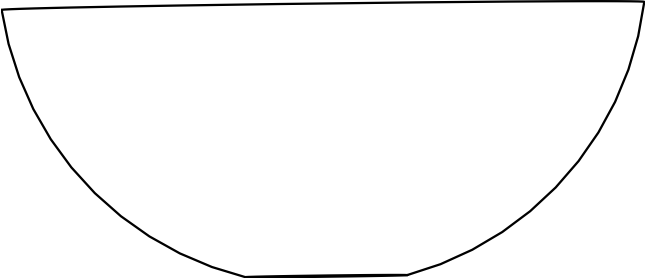
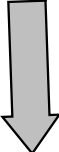
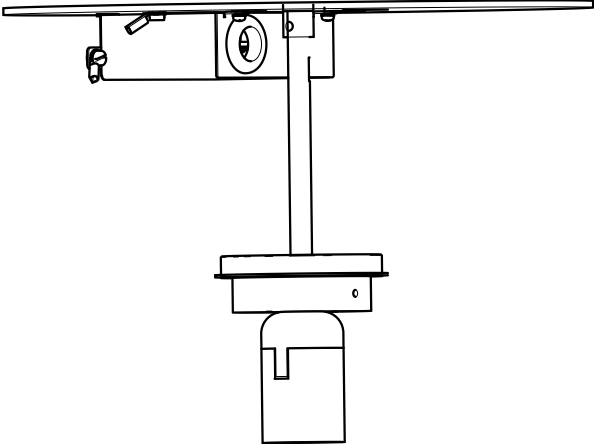

5/ Fixing point preparation

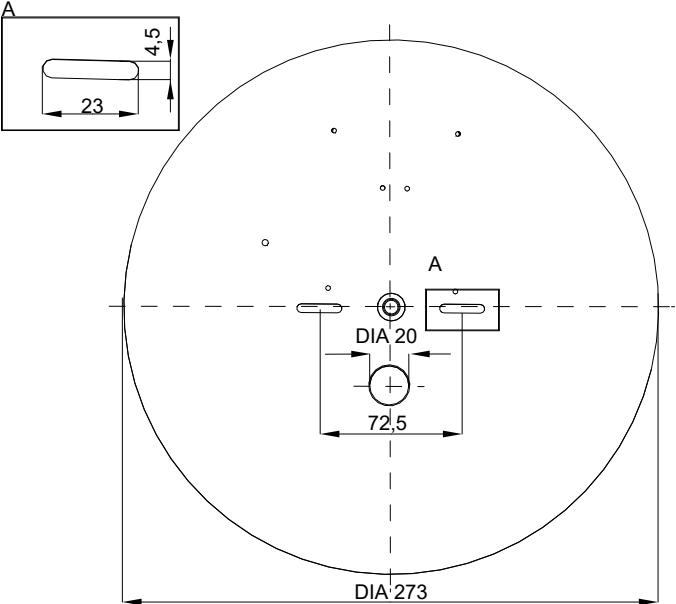

6/ Fixing

Fixing material is not included.

! Lasvit shall not be held liable for any injuries or damage to the fixture or other property caused during installation or by improper fixing. Consulting a specialist before choosing type of fixing materials and procedures for a given fixture is highly recommended.

Pictures shown are for illustration purposes only.

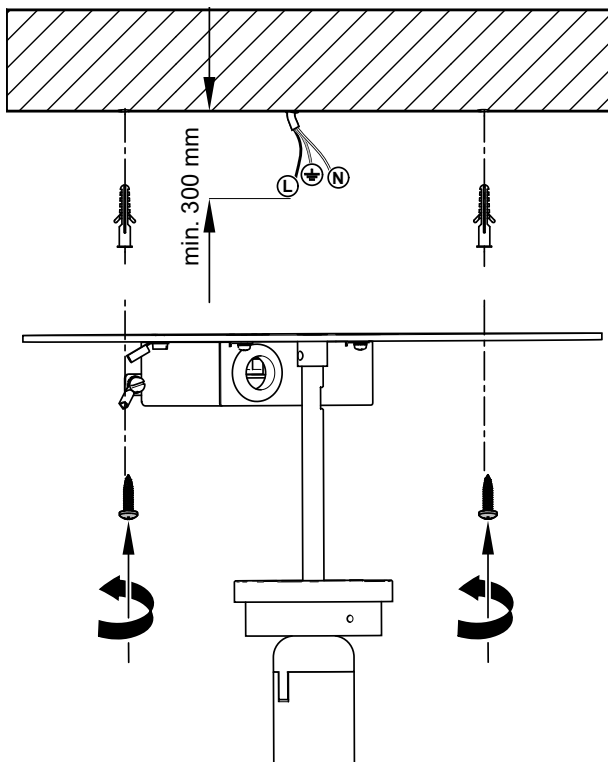

7/ Electrical wiring

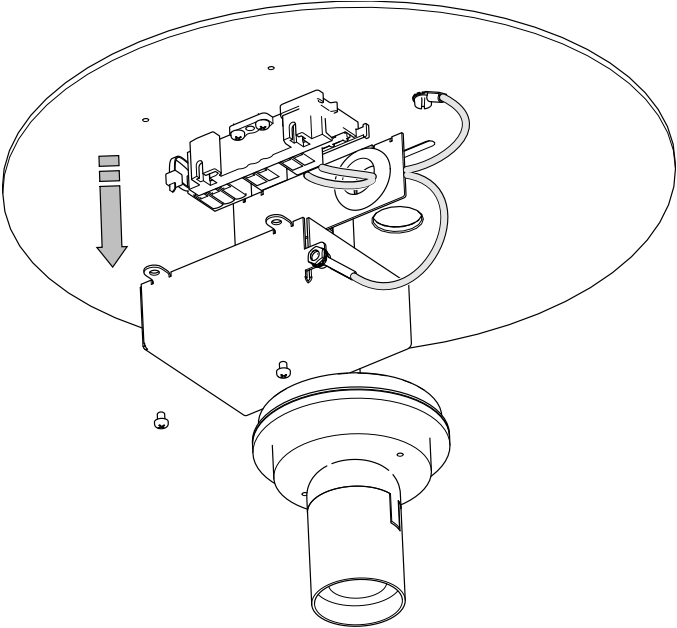
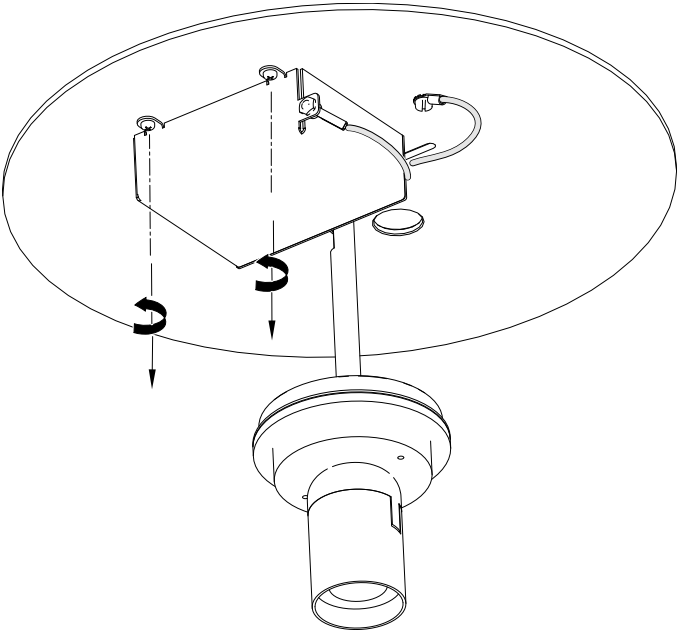

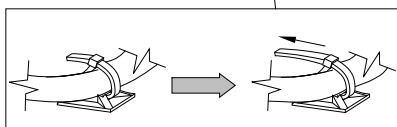
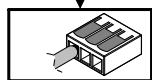
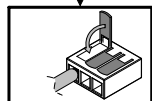
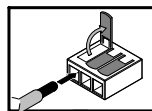
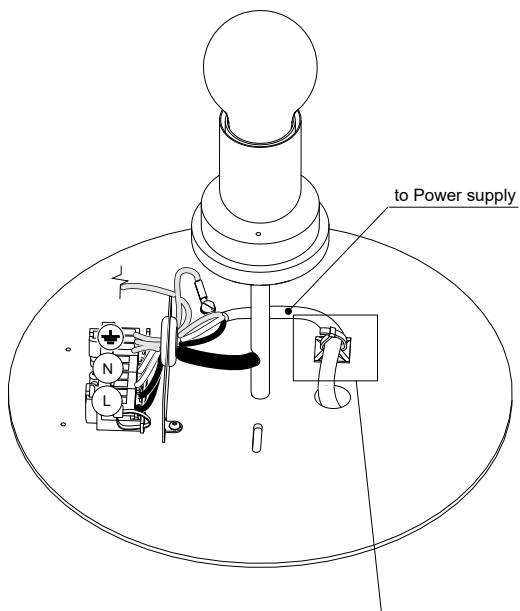

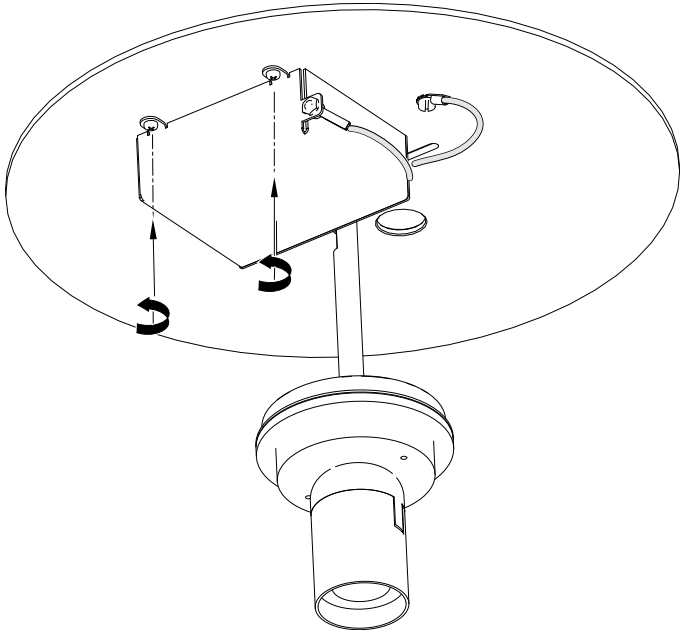
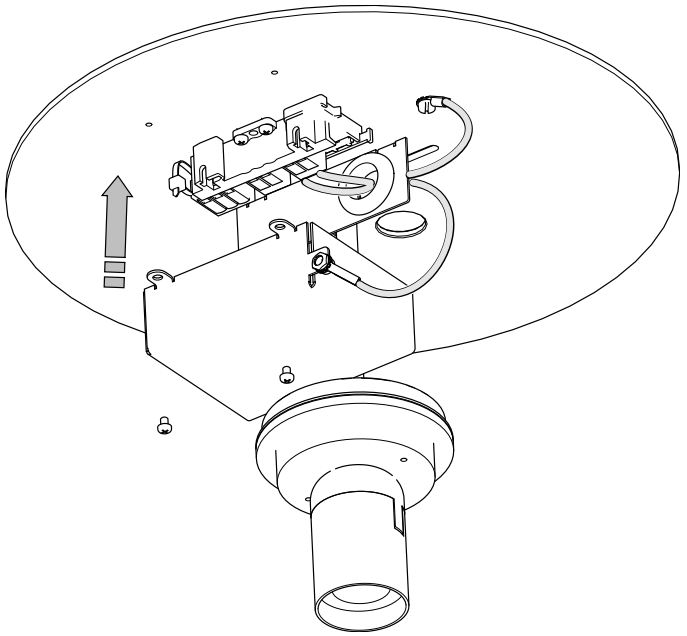

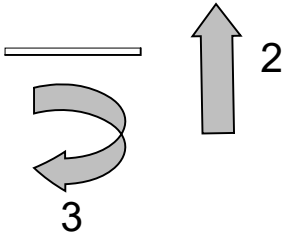
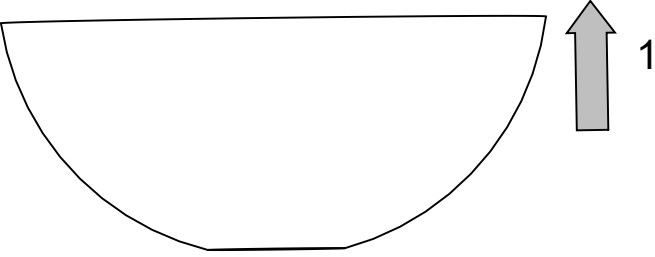
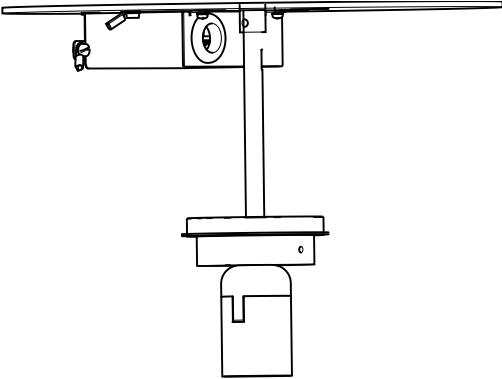

8/ Glass canopy mounting



9/ Light source replacement

 Before starting installation make sure the power to the lighting fixture is switched OFF and secured against unauthorized, negligent or accidental switching on.

 Replacement of the bulb should be carried out by qualified technician to prevent damage to health or property.

The manufacturer shall not be held responsible for injuries, damage to the fixture and/ or other property when other than specified light source type and/ or rating is used.

 All light sources can be supplied by the manufacturer, Lasvit s.r.o.

Lasvit provides NO warranty on bulbs and is not responsible for any damage or injury caused during its installation or during its operation.

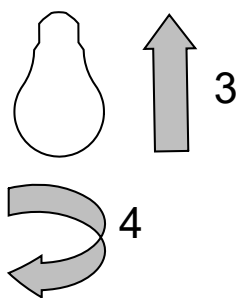
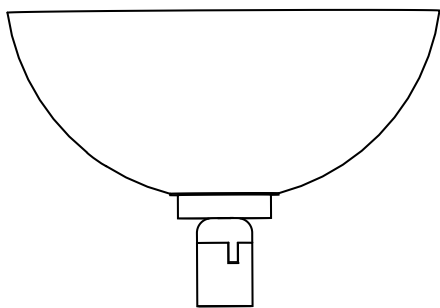
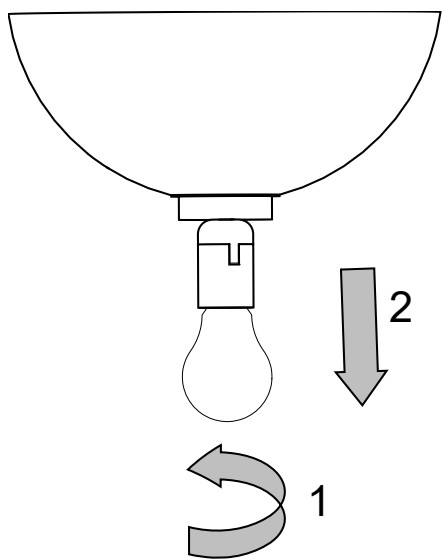

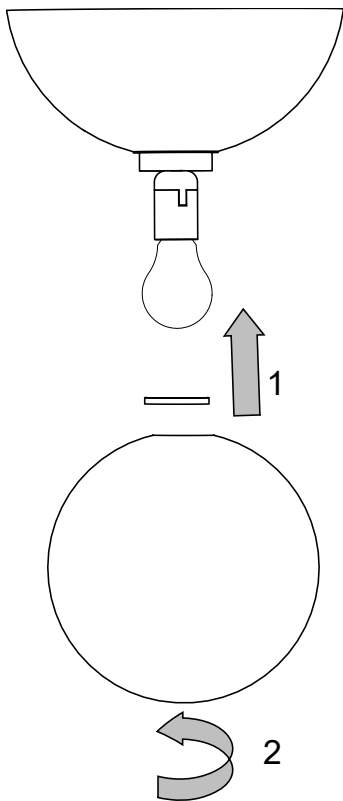

Carry out this step in reverse to fit the new bulb.

Plug in the light again.

10/ Warranties and Warranty Terms and Conditions

1/ The warranty is defined in the Price Quotation, Price Agreement, Contract, or Order. If the Price Quote, contract, or order is not issued, the warranty does not apply to resources, maintenance, service and cleaning and the standard warranty on the goods is set for 2 years. Other agreed warranties must be specified in the Price Quotation, Price Agreement, Contract, or Order.

2/ As a basis for the claim, the customer must provide a valid contract, invoice, or other proof of payment. Otherwise, the manufacturer reserves the right to refuse to provide a warranty, so keep the proof of product purchase carefully.

3/ If the warranty applies to the defect found, the customer informs the seller by e-mail, telephone, or the Sales department of the manufacturer (Lasvit) and passes the required information (project number or light number, project or light name and describes the defect).

4/ The Sales Department proceeds on the basis of an internal customer complaint resolution directive.

5/ The manufacturer will analyse the occurrence of a disagreement with the customer or with the manufacturer after delivery of the non-conforming product to the manufacturer's premises.

6/ Once the analysis has been made, the Sales department is handed over the decision to accept or reject the complaint with an explanation.

7/ The Sales department agrees with the customer for further steps (e.g. repair or replacement date, etc. on the basis of customer and manufacturer possibilities). Unless otherwise agreed, the manufacturer is obliged to remove the defect within 30 days of the claim date at the manufacturer's expense.

8/ The warranty does not apply to:

- defects caused by the customer
- defects caused by a third party
- defects caused by regular usage
- defects caused by an installation contrary to the installation manual
- defects caused by inappropriate attachment or product connection
- defects caused by performed in contradiction with the cleaning manual
- defects caused by the use of other than defined light sources
- defects caused by installation in premises that do not correspond to the nature of the light and its IP cover (intrusion protection).
- defects caused by force majeure

9/ The company LASVIT has the exclusive right to grant, deny or change the terms and conditions for the provision of warranty services.





Lasvit s.r.o. / Komunardů 32 / 170 00 Praha 7 /
Czech Republic T +420 481 120 810 / F +420 481 120 622 /
E lasvit@lasvit.com lasvit.com

In case you need any assistance or have any suggestion, please contact us at

lasvit.com